

- NOTES
- UNLESS OTHERWISE NOTED ALL DIMENSIONS ARE IN MILLIMETERS.
  - UNLESS OTHERWISE NOTED OUTSIDE PROJECTION OF NOZZLES ARE MEASURED FROM C.L. OF EXCHANGER TO THE EXTREME FACE OF NOZZLE.
  - ALL WELDS CONTINUOUS EXCEPT NOTED.
  - BOLT HOLES FOR FLANGES SHALL BE STRADDLED TO EQUIPMENT MAIN AXIS.
  - ALL R.F. FLANGES SHALL HAVE SMOOTH FINISH FACING WITH RA= 3.2mm TO RA= 6.3mm.
  - BASE LINE (B.L.) INDICATES THE GASKET CONTACT SURFACE OF TUBE SHEET.
  - REINFORCING PADS FOR NOZZLES SHALL BE TAPPED WITH AT LEAST ONE (1) TELL TALE HOLE NPT 1/4" WITH VENT PIPE.
- 
- DIMENSIONS REFER TO BAFFLES ARE MEASURED FROM C.L.O.F EACH PLATE.
  - GASKET MATERIAL FOR ASME B16.20. SPIRAL WOUND (t4.5)
    - FILLER: GRAPHITE
    - INNER RING: 304 S.S.
    - OUTER RING: 304 S.S.
  - GASKET MATERIAL: SPIRAL WOUND (t4.5)
    - FILLER: GRAPHITE
    - INNER RING: 304 S.S.
    - HOOP: 304 S.S.
  - SPARE PART (OPTIONAL)
- | CONSTRUCTION & COMMISSIONING |                 |
|------------------------------|-----------------|
| GASKETS                      | 100%            |
| STUD BOLTS & NUTS            | 5% (MIN. 2SETS) |
- ALL EXPOSED SURFACE SHALL BE PAINTED AS FOLLOWS: EXPOSED SURFACE FOR EXTERNAL PARTS: EIO27-HSE-VD-QC-PRO-002 EXPOSED SURFACE OF INTERNAL: NOT PARTS REQUIRED
  - 1/1.4 FACTOR FOR LOAD COMBINATION HAS BEEN APPLIED
  - TUBES SHALL BE SEAMLESS
  - GASKET CONTACT SURFACE OF TUBE SHEET & GIRTH FLANGE: RA= 1.6µm (MAX)
  - FURTHER DETAILS TO BE ADDED FOR DISCLAIMER PURPOSES SUCH AS AFTER HYDROTEST TO BE CLEANED AND DRIED.

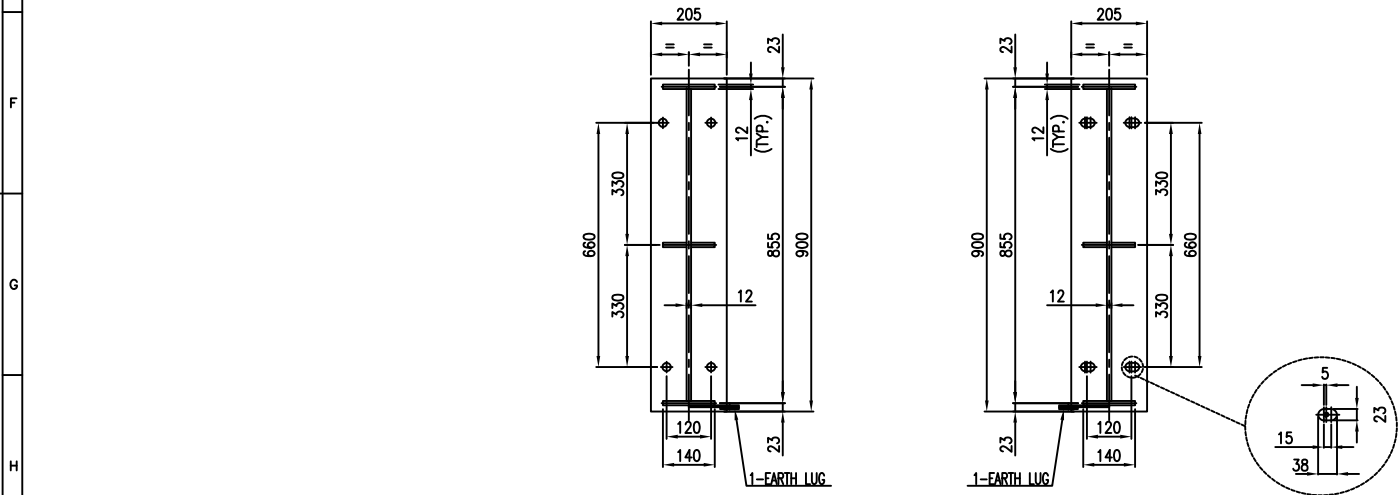

TABLE FOR FOUNDATION LOAD DATA

WIND		SEISMIC (NOTE 13)	
SHEAR (kgf)	MOMENT (kgf-m)	SHEAR (kgf)	MOMENT (kgf-m)
478	430	970	873

MATERIALS

SHELL		GENERAL	
BARREL	SA516-70N	SLIDING BAR/ROD	SA516 70/SA36
FLANGES	SA350-LF2 CL.1N	SEALING STRIP	SA516 70
NOZZLE FROM PIPE	SA333-6	DUMMY TUBE/SEAL ROD	-
NOZZLE FROM PLATE	SA516-70N	BLINDED NOZZLE BOLT/NUT	SA320 L7/SA194-4
NOZZLE FLANGES	SA350-LF2 CL.1N	BLINDED NOZZLE GASKET	SEE NOTE "9"
COUPLINGS & PLUGS	-	TEST RING	SA-266 2
NOZZLE REINF. PAD	SA516-70N	GASKETS	
EXCHANGERS SUPPORTS	SA283-C	SHELL/COVER	-
SUPPORT WEAR PLATE	SA516-70N	SHELL/TUBESHEET	SEE NOTE "10"
STIFFENING RINGS	SA516-70N	CHANNEL/TUBESHEET	SEE NOTE "10"
EXPANSION JOINT	-	CHANNEL/COVER	-
LINING	-	FLOATING HEAD	-
SHELL COVER		FLOATING HEAD	
BARREL	-	COVER	-
COVER	-	FLANGES	-
FLANGES	-	SPLIT RING	-
CHANNEL		BOLTS & NUTS	
BARREL	SA516-70N	SHELL/COVER	-
FLANGES	SA266-2N	SHELL/CHANNEL	SA320-L7/SA194-4
COVER	SA516-70N	CHANNEL/COVER	-
FLAT COVER	-	FLOATING HEAD	-
NOZZLE FROM PIPE	SA106-B	SETTING BOLTS/NUTS	SA193 B7 / SA194 2H
NOZZLE REINF.	SA516-70N	TUBE BUNDLE	
NOZZLE FLANGES	SA105N	TUBES	SA334-6
COUPLINGS & PLUGS	-	TUBESHEETS	SA350-LF2 CL.1N
NOZZLE REINF. PAD	SA516-70N	BAFFLES/SUPPORTS/IMP. PLATE	SA516-70
PARTITION PLATES	SA516-70N	TIE RODS & SPACERS	SA36/SA179

DESIGN DATA

CODE	ASME SEC. VIII DIV.1 (2021 ED.)	TYPE	H-BKU
TEMA CLASS	TEMA 10TH ED. (CLASS "R")	CODE STAMP	NO
LOCAL REGULATION	NO	WIND / SEISMIC CODE	UBC 97
FLUID	PROPANE	STYRENE	WIND EXPOSURE / VELOCITY (km/h)
DESIGN (INT.EXT.)	PRESS. barg	22/F.V.	6.8
TEMP. (°C)	120/85	85	SEISMIC IMPROVANCE FACTOR/RESPONSE FACTOR
STEAM OUT CONDITION	-	-	INSULATION (TYPE/THK.)
OPER. (INT.EXT.)	PRESS. barg	3.813	4.5
TEMP. (°C)	1.24/1	15.2/5	FIRE PROOFING (mm)
CORROSION ALLOWANCE (mm)	3	3	PAINTING
JOINT EFFICIENCY (S/H)	1.0/1.0	1.0/1.0	SEE NOTE "12"
RADIOGRAPHY (S/H)	FULL/FULL	FULL/FULL	NO. OF PASS
HYDRO. TEST PRESS. (SHOP/FIELD)	28.6/28.6	8.84/8.84	1(ONE) 4(FOUR)
HYDRO. TEST TYPE	(U-900) NONE (S)	(U-900) NONE (S)	WEIGHT
PNEUM. TEST PRESS. barg	-	-	BUNDLE (KG)
M.D.M.T (°C)	-45	-29	ERECTOR (KG)
MAWP (HOT & CORRODED) barg	22	6.8	EMPTY (KG)
M.A.P (NEW & COLD) barg	22	6.8	OPER. (KG)
P.W.H.T	NO	NO	FULL WATER (KG)
IMPACT TEST	NO	NO	NO. OF PASS
S.R OF HEAD AFTER COLD FORMING	YES	YES	1(ONE) 4(FOUR)
			MEAN METAL TEMP. (°C)
			-
			SHELL SIDE/TUBE SIDE

NOZZLE LIST

NOZZLE MARK	Q'TY	SIZE (INCH)	FLANGE RATING	SCH.	SERVICE	H/EX. C.L. PROJECTION	REINF. PAD TH'K	O.D.
S1	1	4"	ASME B16.5 300# WNRF	120	SHELL SIDE INLET	SEE DWG.	12	220
S2	1	6"	ASME B16.5 300# WNRF	80	SHELL SIDE OUTLET	SEE DWG.	12	300
T1	1	3"	ASME B16.5 150# WNRF	80	CHANNEL SIDE INLET	SEE DWG.	10	190
T2	1	3"	ASME B16.5 150# WNRF	80	CHANNEL SIDE OUTLET	SEE DWG.	10	190
D1	1	2"	ASME B16.5 300# LWNRF	160	SHELL SIDE DRAIN	SEE DWG.	-	-
D2	1	2"	ASME B16.5 300# LWNRF	160	OIL RECOVERY	SEE DWG.	-	-
LG1	1	2"	ASME B16.5 300# WNRF	160	LEVEL GAUGE	SEE DWG.	-	-
LG2	1	2"	ASME B16.5 300# WNRF	160	LEVEL GAUGE	SEE DWG.	-	-
PSV	1	3"	ASME B16.5 300# WNRF	160	PRESSURE SAFETY VALVE	675	12	190
V	1	2"	ASME B16.5 300# LWNRF	t16.6	VENT	675	-	-
S3	1	2"	ASME B16.5 300# WNRF	160	SHELL SPARE/PURGE	SEE DWG.	-	-

LEGEND

B.L. = BASE LINE  
 C.L. = CENTER LINE  
 M.D.M.T. = MIN. DESIGN METAL TEMPERATURE  
 N. = NORMALIZED  
 O.T.L. = OUTER TUBE LINE  
 C.O.G. = CENTER OF GRAVITY  
 T.O.G. = TOP OF GROUTING  
 W.P. = WORKING POINT

REFERENCE DRAWING	DWG NO.	REV.
-	-	-

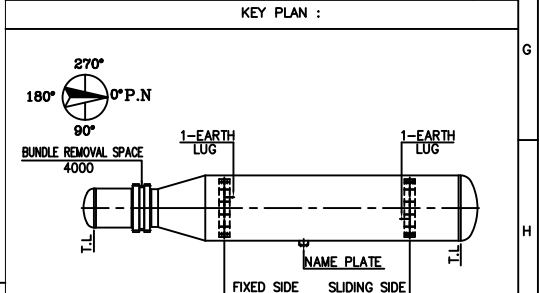

REV.	ISSUE DATE	DESCRIPTION	PREPARED	CHECKED	APPROVED
R3	11.10.2024	ISSUED FOR APPROVAL (IFA)	D.SH.	M.O.	A.M.
R2	09.14.2024	ISSUED FOR APPROVAL (IFA)	D.SH.	M.O.	A.M.
R1	06.27.2024	ISSUED FOR APPROVAL (IFA)	D.SH.	M.O.	A.M.
R0	04.21.2024	ISSUED FOR APPROVAL (IFA)	D.SH.	M.O.	A.M.

CLIENT

CONSULTING ENGINEER

PROJECT: **STYRENE PARK OFFSITE**

DRAWING TITLE: **GENERAL ARRANGEMENT DRAWING FOR CHILLER (EVAPORATOR)**

DRAWING NO.	REV.	SIZE	SCALE	SHEET
EIO27-HSE-VD-ME-DWG-008	R3	A3	NTC	1 of 8





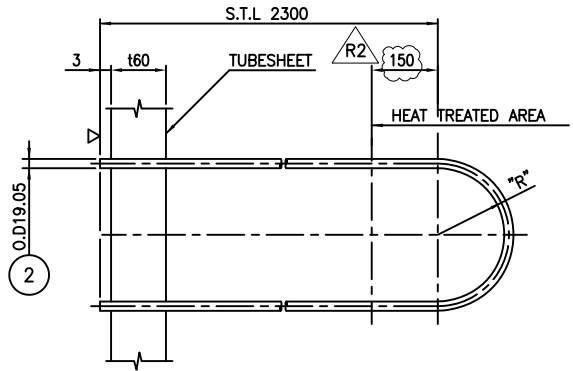
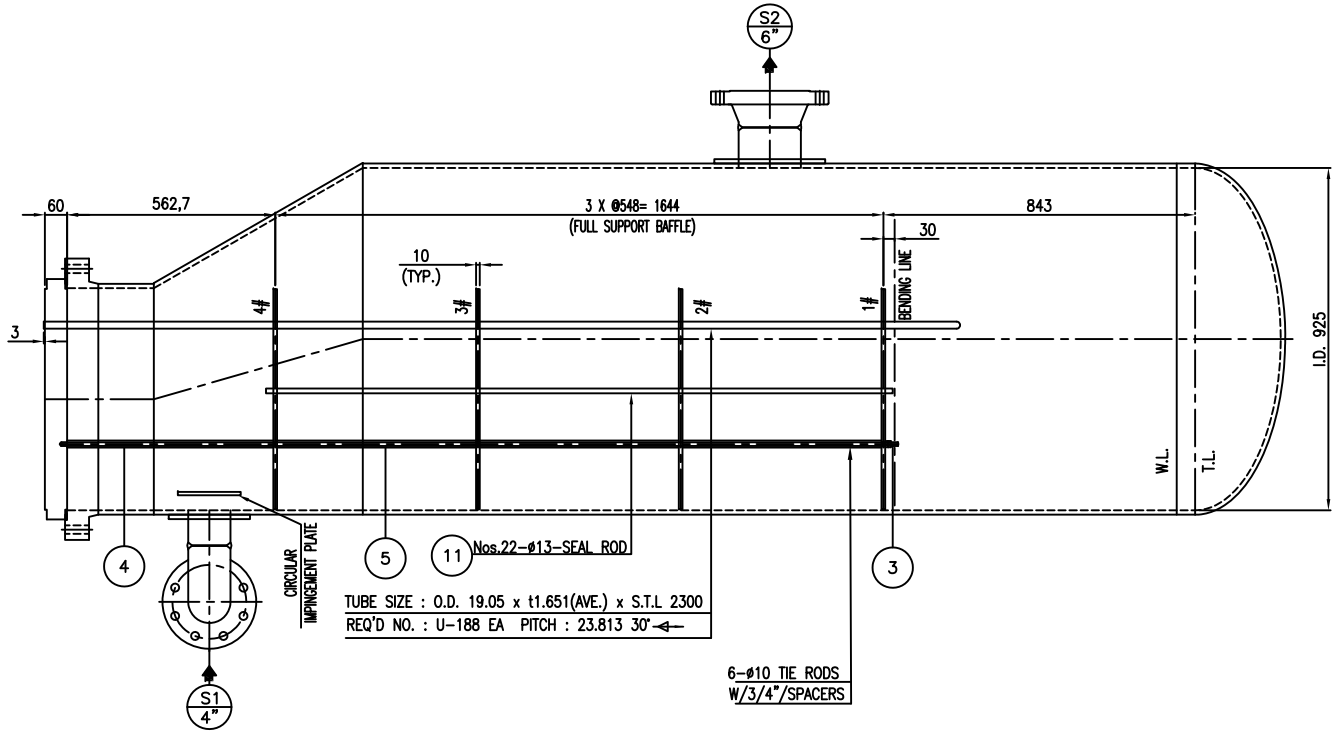

**U-TUBE**

NO.	"R"	"L"	Q'TY
1	35.72	4712.2	10
2	47.63	4749.6	10
3	59.53	4787.0	10
4	71.44	4824.4	10
5	83.35	4861.8	10
6	95.25	4899.3	10
7	107.16	4936.7	10
8	119.07	4974.1	10
9	130.98	5011.5	10
10	142.88	5048.9	10
11	154.79	5086.3	10
12	166.70	5123.7	10
13	178.60	5161.1	10
14	190.51	5198.5	10
15	202.42	5235.9	8
16	214.33	5273.3	10
17	226.23	5310.7	8
18	238.14	5348.1	8
19	250.05	5385.5	6
20	261.95	5422.9	6
21	273.86	5460.4	2

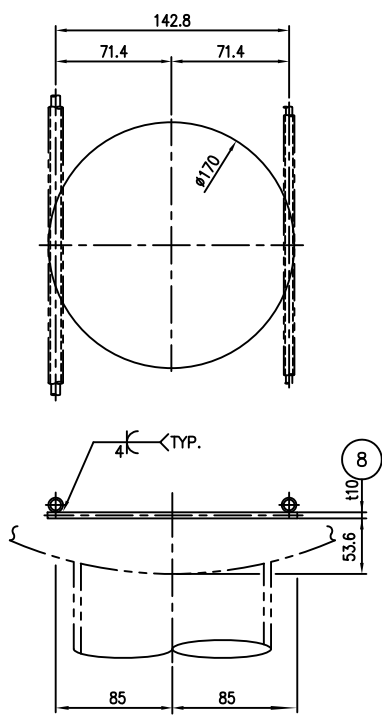

**IMPINGEMENT PLATE**

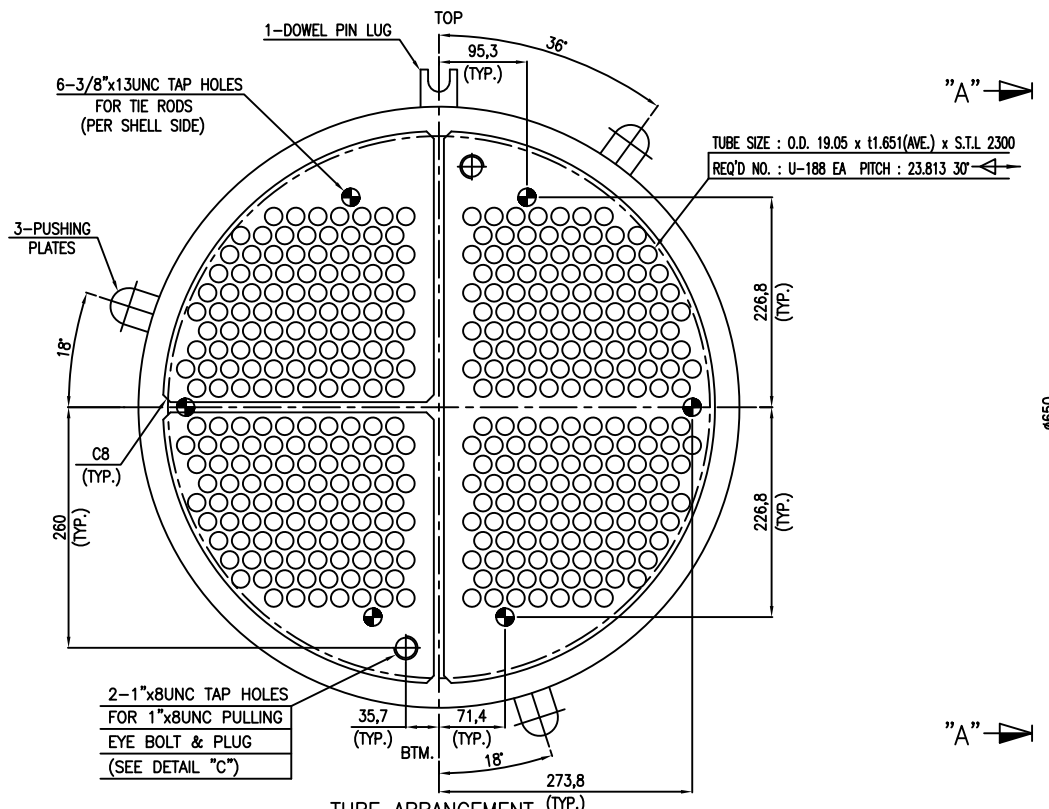

**TUBE ARRANGEMENT (VIEW "A"- "A")**

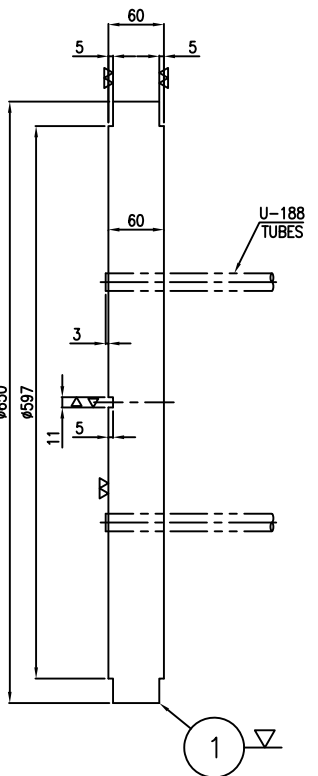

**TUBESHEET DETAIL**

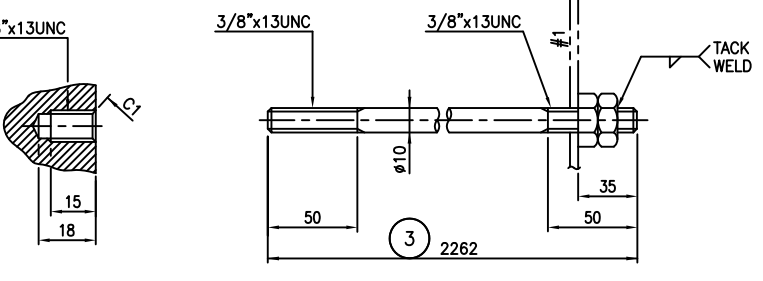

**TIE ROD & 2 NUTS**

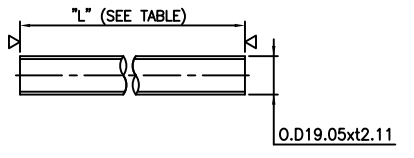

PART NO.	Q'TY	"L"
4	6	558
5	18	538

**SPACER**

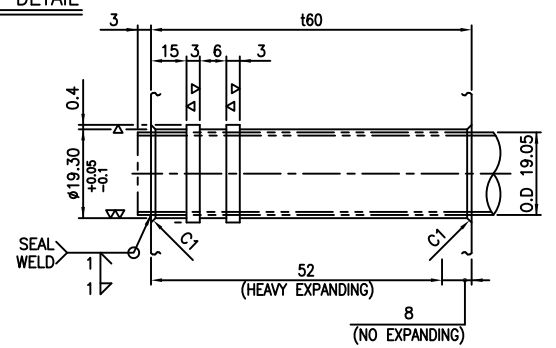

**TUBE TO TUBESHEET JOINT**

**6 EYE BOLT**

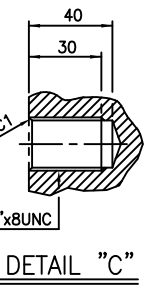

**7 PLUG**

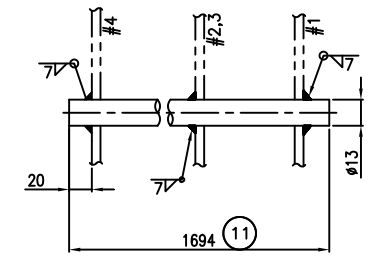
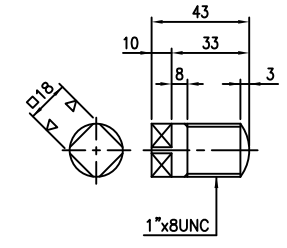

**SEALING ROD**

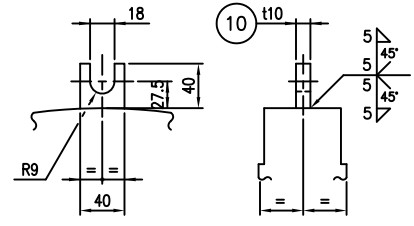

**DOWEL PIN LUG**

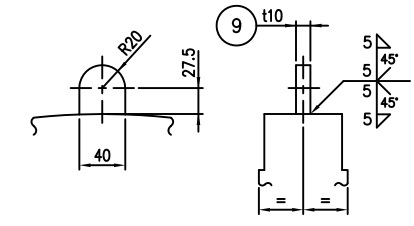

**PUSHING PLATE**

**NOTES**

1. UNLESS OTHERWISE NOTED ALL DIMENSIONS ARE IN MILLIMETERS.

\* FOR ONE SET

NO.	PART NAME	MATERIAL	REGULAR QUANTITY	SPARE QUANTITY	SPECIFICATION	REMARK
11	SEAL ROD	SA-36	22		R.B. #13, L=1694	
10	DOWEL PIN LUG	SA516-70N	1		t10 x 40 x 40	
9	PUSHING PLATE	SA283-C	3		t10 x 34 x 47.5	
8	IMPINGEMENT PLATE	SA516-70N	1		t10 x Ø170	
7	PLUG	304 S.S	2		1"x8UNC	
6	EYE BOLT	SA36	2		1"x8UNC	
5	SPACER	SA334-6	18		Ø19.05 x t1.651 x L538	
4	TIE ROD & 2NUTS	SA334-6	6		Ø19.05 x t1.651 x L538	
3	TIE ROD & 2NUTS	SA36/SA194-2H	6SETS		3/8"x13UNC (Ø10) x L282	
2	TUBE	SA334-6	U-188		Ø19.05 x t1.651 x S.T.L2300	
1	TUBESHEET	SA350-LF2 CL.1N	1		160x Ø650	

**BILL OF MATERIAL**

REV.	ISSUE DATE	DESCRIPTION	PREPARED	CHECKED	APPROVED
R2	09.14.2024	ISSUED FOR APPROVAL (IFA)	D.SH.	M.O.	A.M.
R1	07.13.2024	ISSUED FOR APPROVAL (IFA)	D.SH.	M.O.	A.M.
R0	06.27.2024	ISSUED FOR APPROVAL (IFA)	D.SH.	M.O.	A.M.

CLIENT



پتروشیمی توسعه پارک  
مهندسی گودر افغان

CONSULTING ENGINEER

PROJECT: **STYRENE PARK OFFSITE**

DRAWING TITLE: **BUNDLE DETAIL DRAWING FOR CHILLER (EVAPORATOR) (2/2)**

DRAWING NO.	REV.	SIZE	SCALE	SHEET
EIO27-HSE-VD-ME-DWG-008	R2	A3	NTC	4 of 8

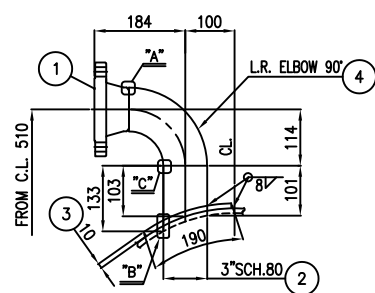

DETAIL OF T1 T2  
3\"/>

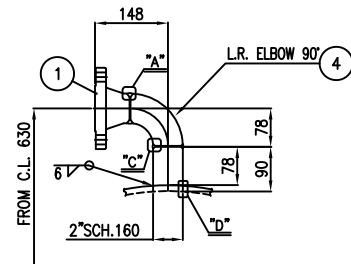

DETAIL OF D1 D2 S3  
2\"/>

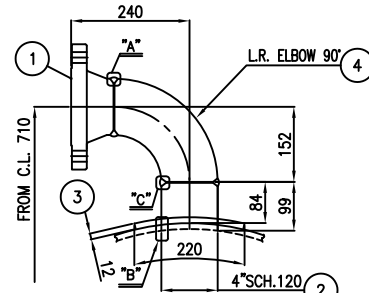

DETAIL OF S1  
4\"/>

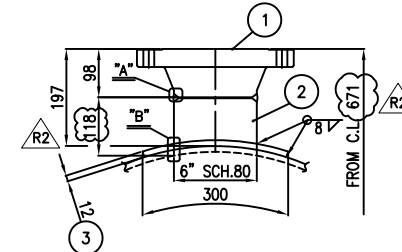

DETAIL OF S2  
6\"/>

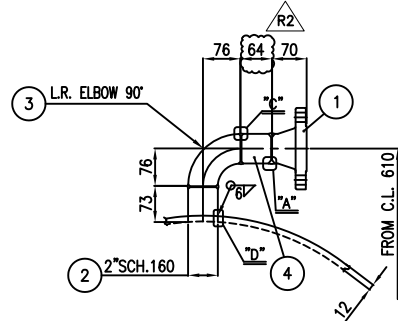

DETAIL OF LG1 LG2  
2\"/>

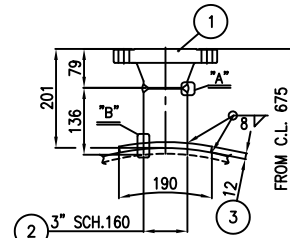

DETAIL OF PSV  
3\"/>

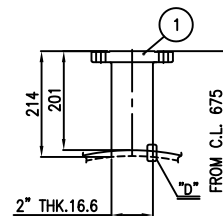

DETAIL OF V  
2\"/>

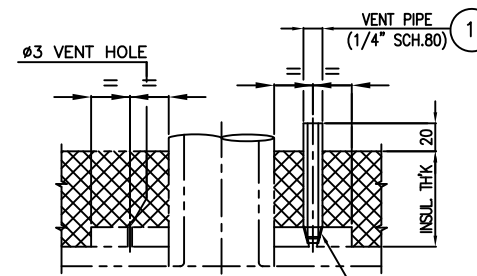

HOLES ON REINF. PAD  
(SEE NOTE 2,3)

- NOTES**
- UNLESS OTHERWISE NOTED ALL DIMENSIONS ARE IN MILLIMETERS.
  - FOR THE TEST VENT HOLES #3 WILL BE OBTURED BY WELDING.
  - AFTER TEST 1/4" HOLE SHALL BE FILLED WITH THREADED TUBE EXTENDING BEYOND INSULATION.

**BILL OF MATERIAL FOR ONE SET**

NOZZLE NO.	PART NO.	PART NAME	MATERIAL	REGULAR QUANTITY	SPARE QUANTITY	SPECIFICATION	REMARK
	2	HALF COUPLING	SA105	5		1/4" ASME 3000#	
	1	VENT PIPE	SA106-B	5		1/4" SCH.80, L70	
	5	DELETED					
LG1	4	NOZZLE NECK	SA333-6	2		2" SCH.160 (L64)	/R2
LG2	3	ELBOW	SA420-WPL6	2		2" SCH.160, LR 90	
	2	NOZZLE NECK	SA333-6	2		2" SCH.160 x L73	
	1	FLANGE (SCH.160)	SA350-LF2 CL.1N	2		2" ASME 300# WNLRF	
D1	3	ELBOW	SA420-WPL6	3		2" SCH.160, LR 90	
D2	2	NOZZLE NECK	SA333-6	3		2" SCH.160 x L90	
S3	1	FLANGE (SCH.160)	SA350-LF2 CL.1N	3		2" ASME 300# WNLRF	
V	1	FLANGE (THK.16.6)	SA350-LF2 CL.1N	1		2" ASME 300# WNLRF	
	3	REINF. PAD	SA516-70N	1		t12 x #220	
S1	2	NOZZLE NECK	SA333-6	1		4" SCH.120 x L131	
	1	FLANGE (SCH.120)	SA350-LF2 CL.1N	1		4" ASME 300# WNLRF	
	3	REINF. PAD	SA516-70N	1		t12 x #190	
PSV	2	NOZZLE NECK	SA333-6	1		3" SCH.160 x L136	
	1	FLANGE (SCH.160)	SA350-LF2 CL.1N	1		3" ASME 300# WNLRF	
	3	REINF. PAD	SA516-70N	1		t12 x #300	
S2	2	NOZZLE NECK	SA333-6	1		6" SCH.80 (L118)	/R2
	1	FLANGE (SCH.80)	SA350-LF2 CL.1N	1		6" ASME 300# WNLRF	
	4	ELBOW	SA424-WPB	2		3" SCH.80, LR 90	
T1	3	REINF. PAD	SA516-70N	2		t10 x #190	
T2	2	NOZZLE NECK	SA106-B	2		3" SCH.80 x L133	
	1	FLANGE (SCH.80)	SA105N	2		3" ASME 150# WNLRF	
	4	ELBOW	SA420-WPL6	1		4" SCH.120, LR 90	
	3	REINF. PAD	SA516-70N	1		t12 x #225	
S1	2	NOZZLE NECK	SA333-6	1		4" SCH.120 x L99	
	1	FLANGE (SCH.120)	SA350-LF2 CL.1N	1		4" ASME 300# WNLRF	

**BILL OF MATERIAL**

REV.	ISSUE DATE	DESCRIPTION	PREPARED	CHECKED	APPROVED
R2	11.10.2024	ISSUED FOR APPROVAL (IFA)	D.SH.	M.O.	A.M.
R1	09.14.2024	ISSUED FOR APPROVAL (IFA)	D.SH.	M.O.	A.M.
R0	06.27.2024	ISSUED FOR APPROVAL (IFA)	D.SH.	M.O.	A.M.

CLIENT



پتروشیمی توسعه پارک  
صنعتی گوهر الماس

CONSULTING ENGINEER

PROJECT: **STYRENE PARK OFFSITE**

DRAWING TITLE: **NOZZLE DETAIL DRAWING FOR CHILLER (EVAPORATOR)**

DRAWING NO.	REV.	SIZE	SCALE	SHEET
EIO27-HSE-VD-ME-DWG-008	R2	A3	NTC	6 of 8

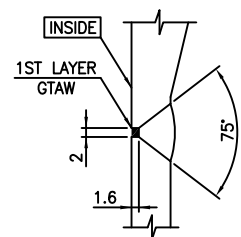

DETAIL "A"

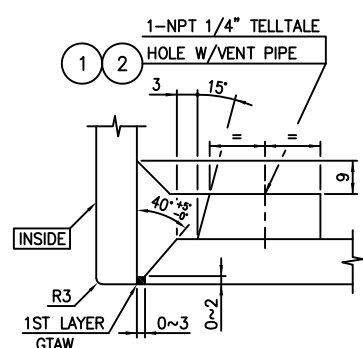

DETAIL "B"

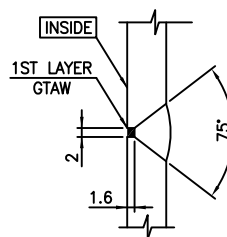

DETAIL "C"

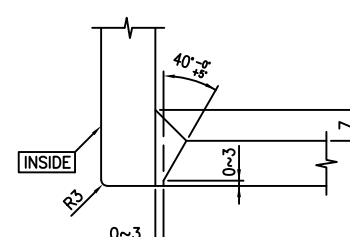

DETAIL "D"

"A"

"A"

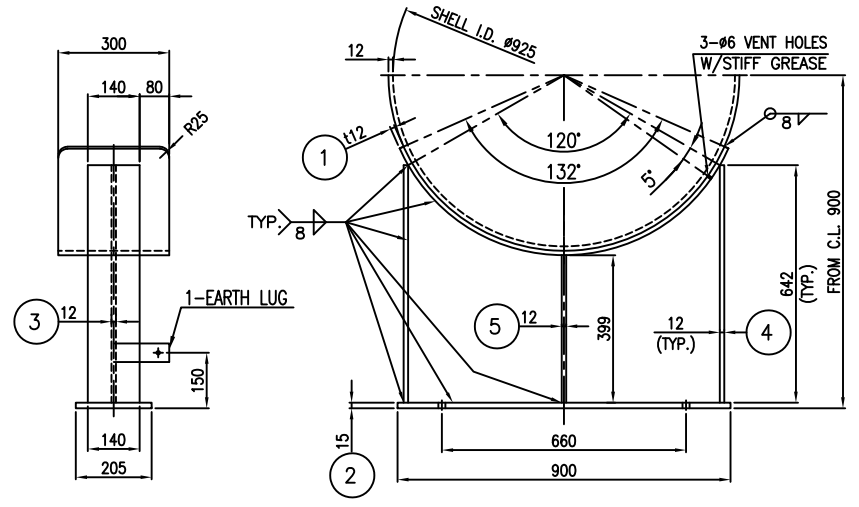

FIXED SIDE

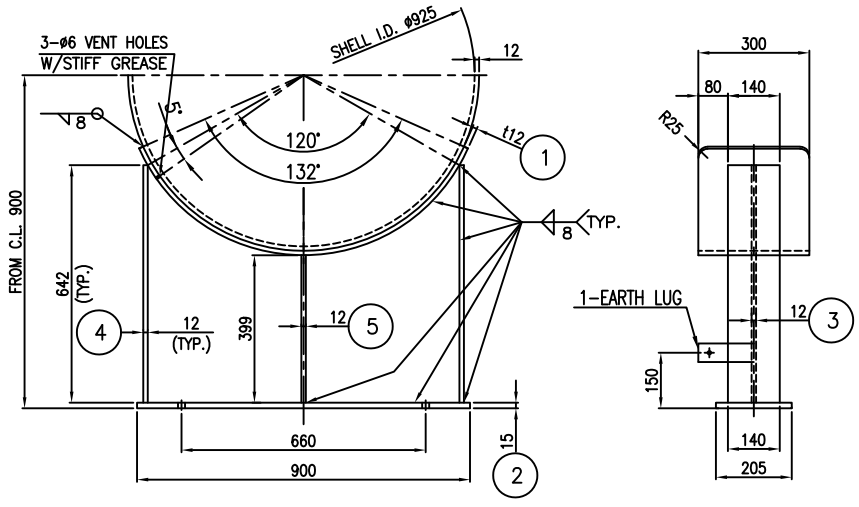

SLIDING SIDE

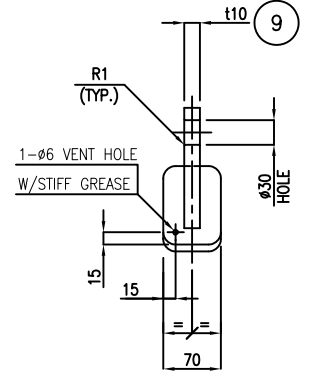
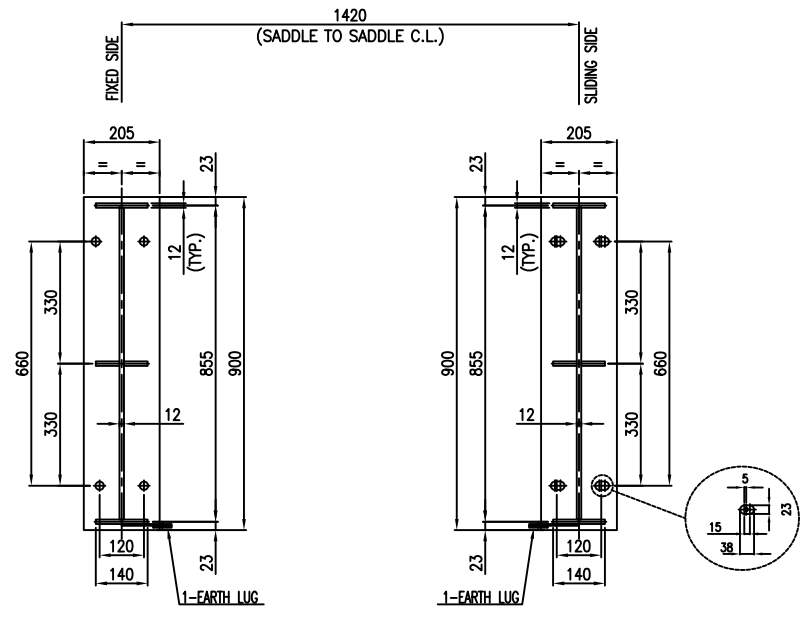

LIFTING LUG DETAIL  
(FOR CHANNEL SIDE)

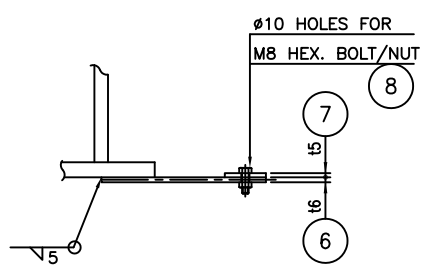
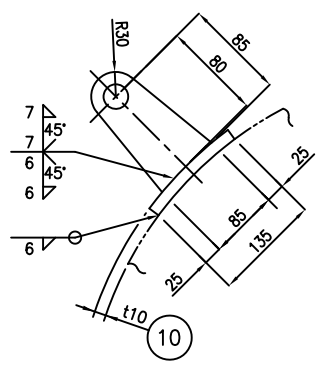

EARTH LUG

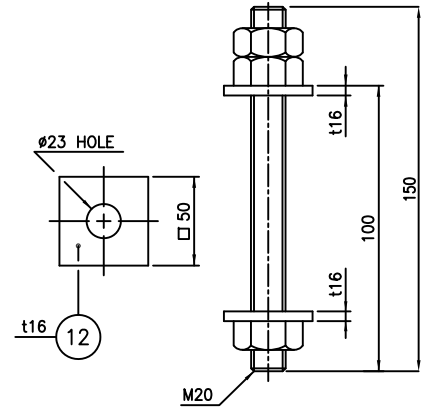

SETTING B/2NS/2W

NOTES  
1. UNLESS OTHERWISE NOTED ALL DIMENSIONS ARE IN MILLIMETERS.  
2. SINCE CABLE LUG IS TINNED COPPER, TINNED CARBON STEEL EARTH LUG.

FOR ONE SET					
PART NO.	PART NAME	MATERIAL	REGULAR QUANTITY	SPARE QUANTITY	REMARK
12	WASHER	SA283-C	32		t16 x t16 (HT DP GRV)
11	SETTING BOLT/2NUTS	SA193-B7/SA194-2H	8SETS		M20 x L150 (HT DP GRV)
10	REINF. PAD	SA516-70N	3		t12 x 70 x 135
9	LIFTING LUG	SA283-C	3		t20 x 85 x 122
8	HEX. BOLT/NUT	S.S. 304	2SETS		M8 x L25
7	COPPER PLATE	SEE NOTE "2"	2		t5 x 50 x 50
6	EARTH LUG	S.S. 304	2		t6 x 50 x 150
5	SUPPORT RIB	SA283-C	4		t12 x 140 x 399
4	SUPPORT RIB	SA283-C	4		t12 x 140 x 642
3	WEB PLATE	SA283-C	2		t12 x 642 x 843
2	BASE PLATE	SA283-C	2		t15 x 205 x 900
1	WEAR PLATE	SA516-70N	2		t12 x 300 x 1107

BILL OF MATERIAL

REV.	ISSUE DATE	DESCRIPTION	PREPARED	CHECKED	APPROVED
R2	09.14.2024	ISSUED FOR APPROVAL (IFA)	D.SH.	M.O.	A.M.
R1	07.21.2024	ISSUED FOR APPROVAL (IFA)	D.SH.	M.O.	A.M.
R0	06.27.2024	ISSUED FOR APPROVAL (IFA)	D.SH.	M.O.	A.M.

CLIENT

CONSULTING ENGINEER

PROJECT: **STYRENE PARK OFFSITE**  
DRAWING TITLE: **SADDLE DETAIL DRAWING FOR CHILLER (EVAPORATOR)**

DRAWING NO.	REV.	SIZE	SCALE	SHEET
EIO27-HSE-VD-ME-DWG-008	R2	A3	NTC	5 of 8

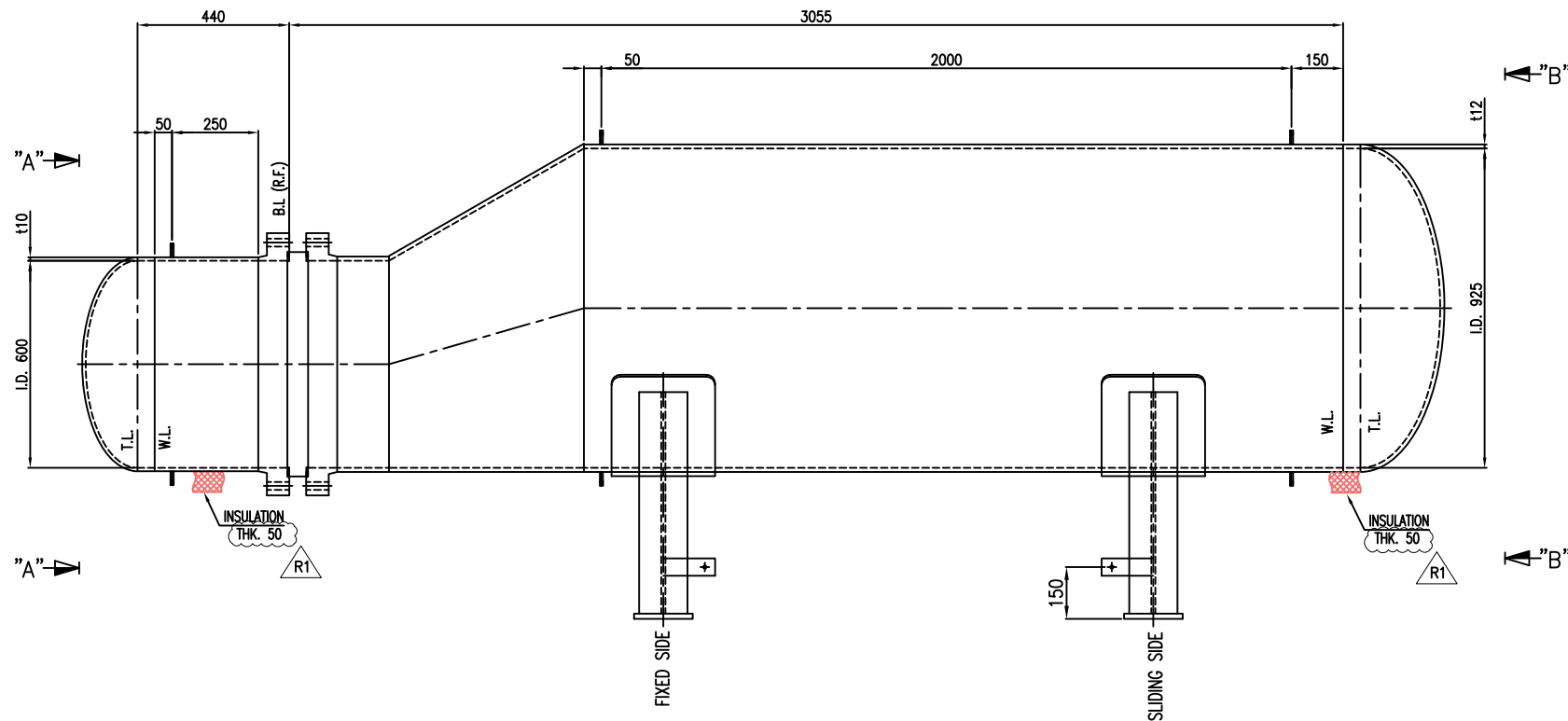

ELEVATION VIEW

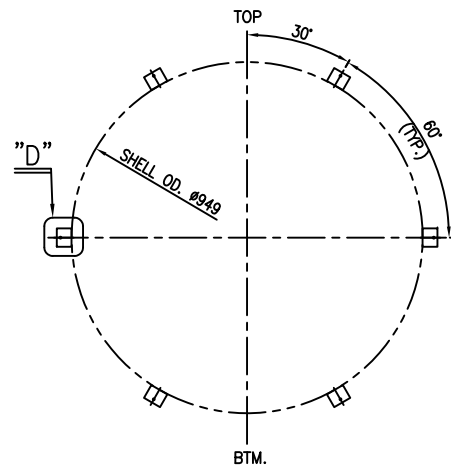

VIEW "B"-"B"

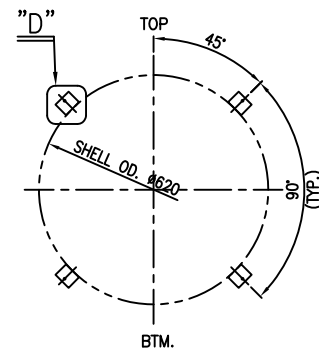

VIEW "A"-"A"

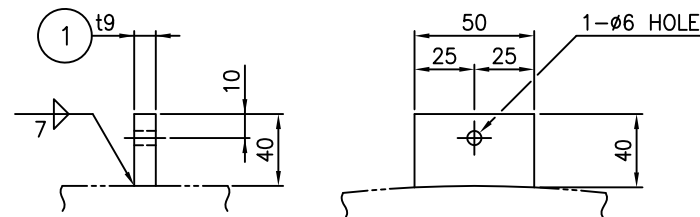

DETAIL "D"

**NOTES**

1. UNLESS OTHERWISE NOTED ALL DIMENSIONS ARE IN MILLIMETERS.

\* FOR ONE SET

PART NO.	PART NAME	MATERIAL	QUANTITY		SPECIFICATION	REMARK
			REGULAR	SPARE		
1	INSUL SUPT CLIP	SA516-70N	16		19 x 40 x 50	

**BILL OF MATERIAL**

REV.	ISSUE DATE	DESCRIPTION	PREPARED	CHECKED	APPROVED
R1	10.18.2024	ISSUED FOR APPROVAL (IFA)	D.SH.	M.O.	A.M.
RO	06.27.2024	ISSUED FOR APPROVAL (IFA)	D.SH.	M.O.	A.M.

CLIENT



CONSULTING ENGINEER

PROJECT: **STYRENE PARK OFFSITE**

DRAWING TITLE:  
**INSULATION CLIP DRAWING FOR  
CHILLER (EVAPORATOR)**

DRAWING NO.	REV.	SIZE	SCALE	SHEET
EI027-HSE-VD-ME-DWG-008	R1	A3	NTC	7 of 8

