



Toase-eh Park Sanati Gohar Ofogh Petrochemical Co.

**CONCEPTUAL, BASIC and DETAIL DESIGN
ENGINEERING OF STYRENE PARK OFFSITE**



Document Title: WELDING & NDT MAP

Document No. : E1027-FPA-VD-QC-NDT-003

Rev.: R0

Page 1 of 9

STYRENE PARK OFFSITE

Document Title:

WELDING & NDT MAP

Rev.	Issued Date	DESCRIPTION	PREPARED	CHECKED	APPROVED
00	29-Aug-2024	IFA	F.Baviye	N.Abnavi	N.Abnavi



Toase-che Park Sanati Gohar Ofogh Petrochemical Co.

**CONCEPTUAL, BASIC and DETAIL DESIGN ENGINEERING OF
STYRENE PARK OFFSITE**



Document Title: WELDING & NDT MAP

Document No. : E1027-FPA-VD-QC-NDT-003

Rev.: R0

Page 2 of 9

Page	Revisions							Page	Revisions						
	R0	R1	R2	R3	R4	R5	R6		R0	R1	R2	R3	R4	R5	R6
1	X							41							
2	X							42							
3	X							43							
4	X							44							
5	X							45							
6	X							46							
7	X							47							
8	X							48							
9	X							49							
10								50							
11								51							
12								52							
13								53							
14								54							
15								55							
16								56							
17								57							
18								58							
19								59							
20								60							
21								61							
22								62							
23								63							
24								64							
25								65							
26								66							
27								67							
28								68							
29								69							
30								70							
31								71							
32								72							
33								73							
34								74							
35								75							
36								76							
37								77							
38								78							
39								79							
40								80							

DOC. NO.	E1027-FPA-VD-QC-NDT-003		REV.	0
SHEET	3	Of	9	
PROJECT NO.	HX-127			
ITEM	CHILLER			

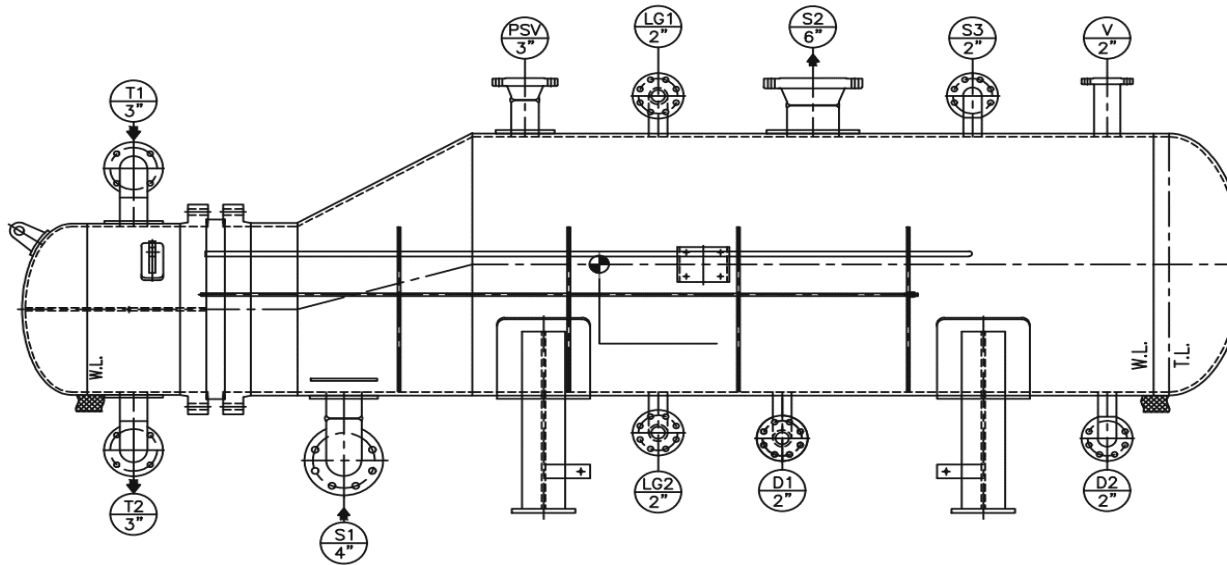

GENERAL INFORMATION			DESCRIPTION MATERIALS			
TYPE OF SERVICE		CHILLER (EVAPORATOR)		SHELL SIDE	BARREL	SA 516 Gr.70
CONSTRUCTION CODE		ASME VIII div.1 Ed.2021 & TEMA R /10th Ed. 2019			NOZZLES (FROM PIPE/PLATE/FLANGE)	SA 333-6/ SA 516 Gr.70 N/SA 350-LF2
M.D.M.T		-45 °C for Shell side & -29°C for Tube side			FLANGES	SA 350-LF2 CL1
DESCRIPTION MATERIALS						
TUBE BUNDLE	TUBES	SA 334-6		SADDLE	COUPLING / PLUG	-
	TUBESHEET	SA 350-LF2 CL1			WEAR PLATE	SA 516 Gr.70 N
	BAFFLES	SA 516 Gr.70			WEB PLATE	SA 283 Gr.C/ SA 516 Gr.70
	TIE RODS / SPACERS	SA 36/SA 179			RIB	SA 283 Gr.C/ SA 516 Gr.70
CHANNEL SIDE	BARREL	SA 516 Gr.70		EARTHING LUG	S.S. 304	
	NOZZLES (FROM PIPE/PLATE/FLANGE)	SA 106-B/SA 516-70N/SA 105N		APPLICABLE DOCUMENTS		
	HEAD	SA 516 Gr.70		GENERAL DRAWINGS	E1027-HSE-VD-ME-DWG-008	
	FLANGE	SA 105 N		PWHT PROCEDURE	NO	
	PIPE	SA 106-B				
ELBOW	SA 234-WPB					

WELDING & NDT MAP

DOC. NO.	E1027-FPA-VD-QC-NDT-003		REV.	0
SHEET	4	Of	9	
PROJECT NO.	HX-127			
ITEM	CHILLER			

SHELL DETAIL

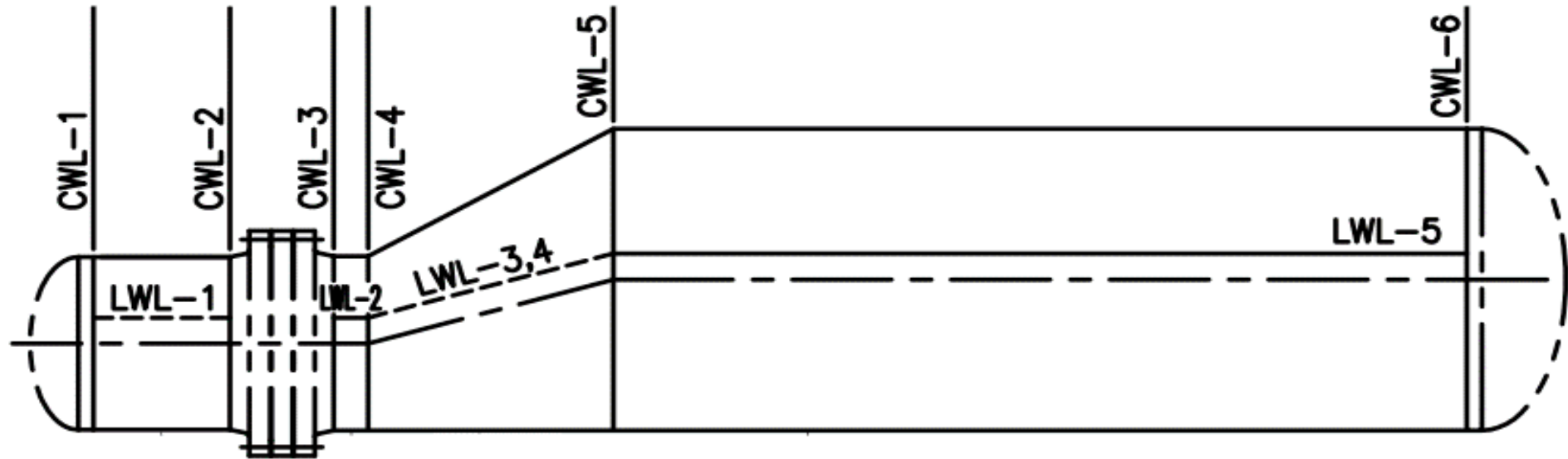

DOC. NO.	E1027-FPA-VD-QC-NDT-003		REV.	0
SHEET	5	Of	9	
PROJECT NO.	HX-127			
ITEM	CHILLER			

NOZZLES DETAIL

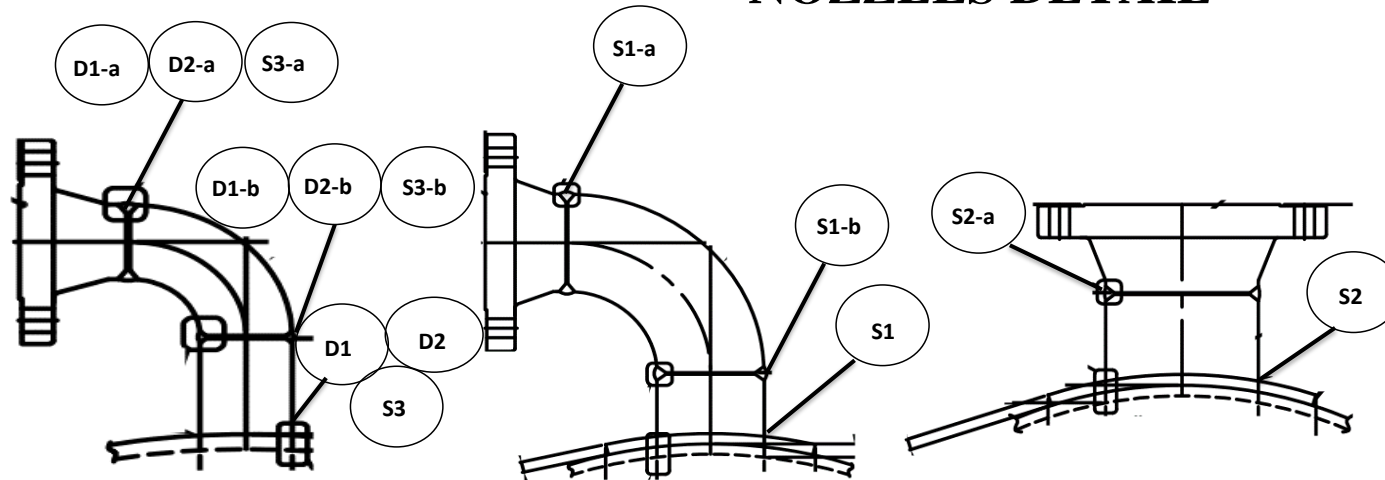

Detail for D1, D2, S3

Detail for S1

Detail for S2

NOZZLE LIST

NOZZLE MARK	Q'TY /1 SET	SIZE (INCH)	FLANGE	
			RATING	SCH.
S1	1	4"	ASME B16.5 300# WN.RF	120
S2	1	6"	ASME B16.5 300# WN.RF	80
T1	1	3"	ASME B16.5 150# WN.RF	80
T2	1	3"	ASME B16.5 150# WN.RF	80
D1	1	2"	ASME B16.5 300# LWN.RF	160
D2	1	2"	ASME B16.5 300# LWN.RF	160
LG1	1	2"	ASME B16.5 300# WN.RF	160
LG2	1	2"	ASME B16.5 300# WN.RF	160
PSV	1	3"	ASME B16.5 300# WN.RF	160
V	1	2"	ASME B16.5 300# LWN.RF	t16.6
S3	1	2"	ASME B16.5 300# WN.RF	160

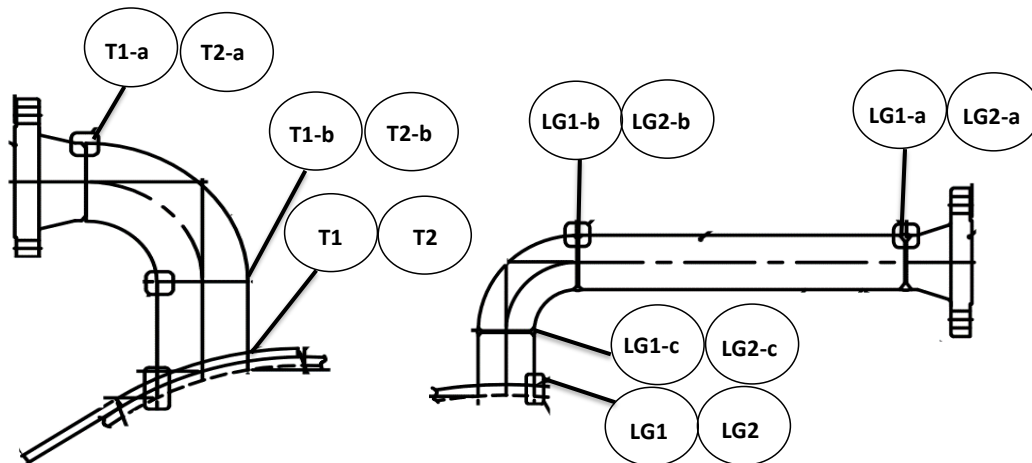

Detail for T1, T2

Detail for LG1, LG2

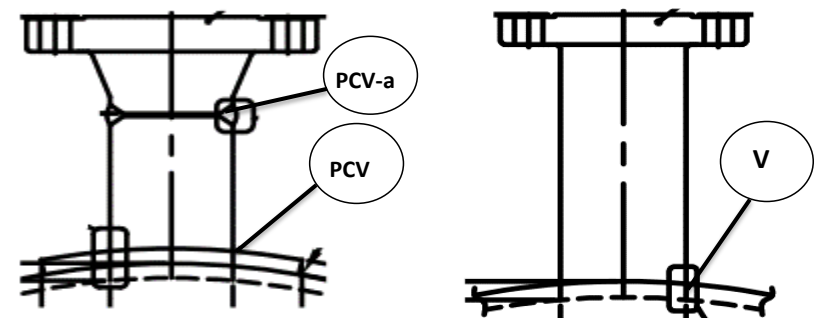

Detail for PSV

Detail for V

WELDING & NDT MAP

DOC. NO.	E1027-FPA-VD-QC-NDT-003		REV.	0
SHEET	6	Of	9	
PROJECT NO.	HX-127			
ITEM	CHILLER			

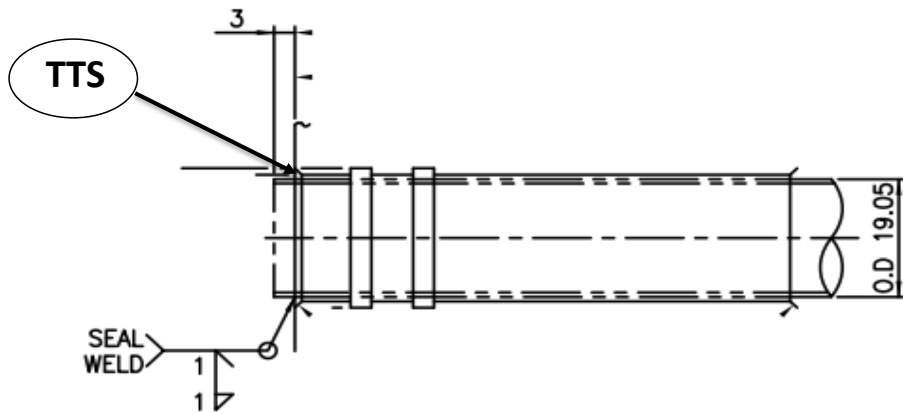

TUBE TO TUBESHEET JOINT

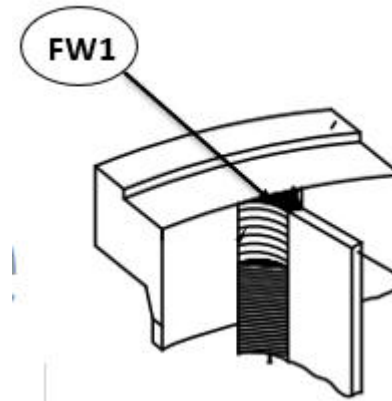

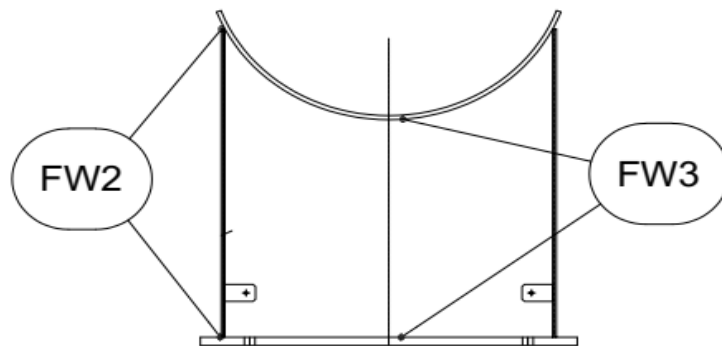

PARTITION PLATE DETAIL

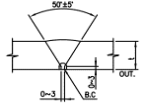
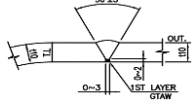
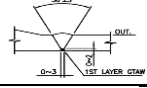

SADDLE DETAIL

DOC. NO.	E1027-FPA-VD-QC-NDT-003		REV.	0
SHEET	7	Of	9	
PROJECT NO.	HX-127			
ITEM	CHILLER			

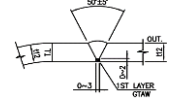
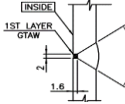
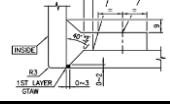
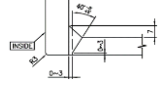
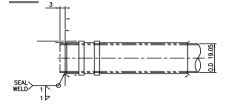
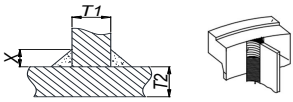
Joint Type	Schematic	Joint
A		LWL-1~LWL-5
B		CWL-1
C		CWL-2,3
D		CWL-4
E		CWL-5
F		CWL-6
G		T1-a,T1-b,T2-a,T2-b,S1-a,S1-b,S2-a,PSV-a,LG1-a,LG2-a,S3-a,LG1-b,LG1-c,LG2-b,LG2-c,T1-a,T1-b,T2-a,T2-b
H		T1,T2,S1,S2,PSV
I		LG1,LG2,D1,D2 ,S3,V
J		TTS
K		FW1,FW2,FW3



Farnikan
Engineered Solutions

WELDING AND NDT MAP

DOC. NO.	E1027-FPA-VD-QC-NDT-003	REV.	0
SHEET	8	Of	9
PROJECT NO.	HX-127		
ITEM	CHILLER		

WELDS LIST

WELD IDENTIFICATION	WELDING PROCESS	BASE MATERIAL		W.P.S.		P.Q.R.		Joint Type	IMPACT TEST	PWHT	NDT
		TYPE AND GRADE	THK. (mm)	NUMBER	REV.	NUMBER	QUALIFIED RANGE(mm)				
LWL-1	GTAW+SMAW	SA-516 Gr.70N	10	WPS-HX127-001	0	FPA-PQR-029	5:50	A	N.A.	N.A.	100% RT
		SA-516 Gr.70N									
LWL-2~LWL-4	GTAW+SMAW/SMAW	SA-516 Gr.70N	12	WPS-HX127-001	0	FPA-PQR-029	5:50	A	N.A.	N.A.	100% RT
		SA-516 Gr.70N									
LWL-5	GTAW+SMAW/SMAW+SAW	SA-516 Gr.70N	12	WPS-HX127-002	0	FPA-PQR-029	5:50	A	N.A.	N.A.	100% RT
		SA-516 Gr.70N									
CWL-1	GTAW+SMAW/GTAW+SMAW+SAW	SA-516 Gr.70N	10	WPS-HX127-002	0	FPA-PQR-029	5:50	B	N.A.	N.A.	100% RT
		SA-516 Gr.70N									
CWL-2	GTAW+SMAW/GTAW+SMAW+SAW	SA-516 Gr.70N	10	WPS-HX127-002	0	FPA-PQR-029	5:50	C	N.A.	N.A.	100% RT
		SA-266-2N									
CWL-3	GTAW+SMAW/SMAW+SAW	SA-516 Gr.70N	12	WPS-HX127-002	0	FPA-PQR-029	5:50	C	N.A.	N.A.	100% RT
		SA-266-2N									
CWL-4	GTAW+SMAW/SMAW+SAW	SA-516 Gr.70N	12	WPS-HX127-002	0	FPA-PQR-029	5:50	D	N.A.	N.A.	100% RT
		SA-516 Gr.70N									
CWL-5,CWL-6	GTAW+SMAW/SMAW+SAW	SA-516 Gr.70N	12	WPS-HX127-002	0	FPA-PQR-029	5:50	E	N.A.	N.A.	100% RT
		SA-516 Gr.70N									
T1,T2	GTAW+SMAW	SA-106 Gr.B	10	WPS-HX127-001	0	FPA-PQR-029	5:50	H	N.A.	N.A.	100% UT
		SA-516 Gr.70N									
S1,S2,PSV	GTAW+SMAW	SA-333 Gr.6	12	WPS-HX127-001	0	FPA-PQR-029	5:50	H	N.A.	N.A.	100% UT
		SA-516 Gr.70N									
LG1, LG2,D1,D2,S3	GTAW+SMAW	SA-333 Gr.6	12	WPS-HX127-001	0	FPA-PQR-029	5:50	I	N.A.	N.A.	100% UT
		SA-516 Gr.70N									
V	GTAW+SMAW	SA-350 LF2	12	WPS-HX127-001	0	FPA-PQR-029	5:50	I	N.A.	N.A.	100% UT
		SA-516 Gr.70N									
T1-a,T1-b,T2-a,T2-b	GTAW+SMAW/GTAW	SA-106 Gr.B	7.62	WPS-HX127-001	0	FPA-PQR-029	5:50	G	N.A.	N.A.	100% PT
		SA 234 WPB6									
		SA-105N									
S1-a,S1-b, S2-a,PSV-a,LG1-a, LG2-a,S3-a	GTAW+SMAW	SA-333 Gr.6	8.74, 11.13, 10.97	WPS-HX127-001	0	FPA-PQR-029	5:50	G	N.A.	N.A.	100% PT
		SA-420 WPL6									
		SA-350 LF2									

