

2:1 ELLIP. HEAD USED TH'K : 12 (MIN. TH'K : 10 AFTER FORMING)

INSULATION THK. 60

CIRCULAR IMPINGEMENT PLATE

1323 (OPC. CONDITION) 1285 (PAB. CONDITION)

1-EARTH LUG

INSULATION THK. 60

2:1 ELLIP. HEAD USED TH'K : 14 (MIN. TH'K : 12 AFTER FORMING)

6-#10 TIE RODS W/3/4" SPACERS

TUBE SIZE : O.D. 19.05 x t1.651(AVE.) x S.T.L. 2300

REQ'D NO. : U-188 EA PITCH : 23.813 30'

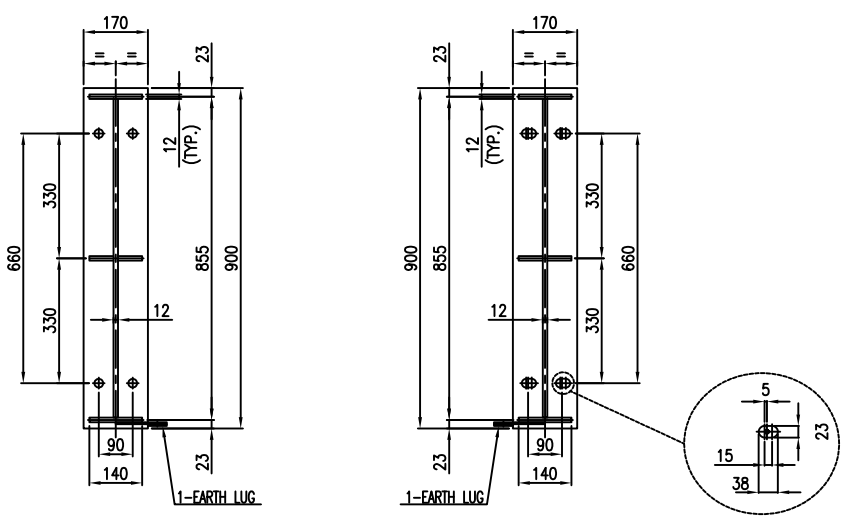

- NOTES
- UNLESS OTHERWISE NOTED ALL DIMENSIONS ARE IN MILLIMETERS.
 - UNLESS OTHERWISE NOTED OUTSIDE PROJECTION OF NOZZLES ARE MEASURED FROM C.L. OF EXCHANGER TO THE EXTREME FACE OF NOZZLE
 - ALL WELDS CONTINUOUS EXCEPT NOTED
 - BOLT HOLES FOR FLANGES SHALL BE STRADDLED TO EQUIPMENT MAIN AXIS
 - ALL R.F. FLANGES SHALL HAVE SMOOTH FINISH FACING WITH RA= 3.2mm TO RA= 6.3mm
 - BASE LINE (B.L.) INDICATES THE GASKET CONTACT SURFACE OF TUBE SHEET
 - REINFORCING PADS FOR NOZZLES SHALL BE TAPPED WITH AT LEAST ONE (1) TELL TALE HOLE NPT 1/4" WITH VENT PIPE.
-
- DIMENSIONS REFER TO BAFFLES ARE MEASURED FROM C.L. OF EACH PLATE
 - GASKET MATERIAL FOR ASME B16.20. SPIRAL WOUND (t4.5)
 - FILLER: GRAPHITE
 - INNER RING: 304 S.S.
 - HOOP: 304 S.S.
 - OUTER RING: 304 S.S.
 - GASKET MATERIAL: SPIRAL WOUND (t4.5)
 - FILLER: GRAPHITE
 - INNER RING: 304 S.S.
 - HOOP: 304 S.S.
 - SPARE PART (OPTIONAL)
- | | CONSTRUCTION & COMMISSIONING |
|-------------------|------------------------------|
| GASKETS | 100% |
| STUD BOLTS & NUTS | 5% (MIN. 2SETS) |
- ALL EXPOSED SURFACE SHALL BE PAINTED AS FOLLOWS: EXPOSED SURFACE FOR EXTERNAL PARTS: E1027-HSE-VD-QC-PRO-002 EXPOSED SURFACE OF INTERNAL: NOT PARTS REQUIRED
 - 1/1.4 FACTOR FOR LOAD COMBINATION HAS BEEN APPLIED
 - TUBES SHALL BE SEAMLESS
 - GASKET CONTACT SURFACE OF TUBE SHEET & GIRTH FLANGE: RA= 1.6µm (MAX)
 - FURTHER DETAILS TO BE ADDED FOR DISCLAIMER PURPOSES SUCH AS AFTER HYDROTEST TO BE CLEANED AND DRIED.

REFERENCE DRAWING	DWG NO.	REV.
-	-	-

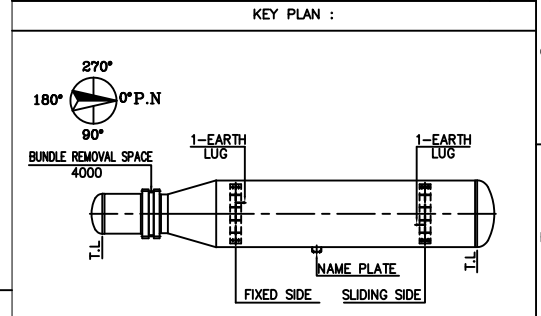

TABLE FOR FOUNDATION LOAD DATA

WIND		SEISMIC (NOTE 13)	
SHEAR (kgf)	MOMENT (kgf-m)	SHEAR (kgf)	MOMENT (kgf-m)
478	430	970	873

MATERIALS

SHELL		GENERAL	
BARREL	SA516-70N	SLIDING BAR/ROD	SA516 70/SA36
FLANGES	SA350-LF2 CL.1N	SEALING STRIP	SA516 70
NOZZLE FROM PIPE	SA333-6	DUMMY TUBE/SEAL ROD	-
NOZZLE FROM PLATE	SA516-70N	BLUNDED NOZZLE BOLT/NUT	SA320 L7/SA194-4
NOZZLE FLANGES	SA350-LF2 CL.1N	BLUNDED NOZZLE GASKET	SEE NOTE "9"
COUPLINGS & PLUGS	-	TEST RING	SA-266 2
NOZZLE REINF. PAD	SA516-70N	GASKETS	
EXCHANGERS SUPPORTS	SA283-C	SHELL/COVER	-
SUPPORT WEAR PLATE	SA516-70N	SHELL/TUBESHEET	SEE NOTE "10"
STIFFENING RINGS	SA516-70N	CHANNEL/TUBESHEET	SEE NOTE "10"
EXPANSION JOINT	-	CHANNEL/COVER	-
LINING	-	FLOATING HEAD	-
SHELL COVER		FLOATING HEAD	
BARREL	-	COVER	-
COVER	-	FLANGES	-
FLANGES	-	SPLIT RING	-
CHANNEL		BOLTS & NUTS	
BARREL	SA516-70N	SHELL/COVER	-
FLANGES	SA266-2N	SHELL/CHANNEL	SA320-L7/SA194-4
COVER	SA516-70N	CHANNEL/COVER	-
FLAT COVER	-	FLOATING HEAD	-
NOZZLE FROM PIPE	SA106-B	SETTING BOLTS/NUTS	SA193 B7 / SA194 2H
NOZZLE REINF.	SA516-70N	TUBE BUNDLE	
NOZZLE FLANGES	SA105N	TUBES	SA334-6
COUPLINGS & PLUGS	-	TUBESHEETS	SA350-LF2 CL1N
NOZZLE REINF. PAD	SA516-70N	BAFFLES/SUPPORTS/MP. PLATE	SA516-70
PARTITION PLATES	SA516-70N	TIE RODS & SPACERS	SA36/SA179

DESIGN DATA

CODE	ASME SEC. VIII DV.1 (2021 ED.)	TYPE	H-BKU
TEMA CLASS	TEMA 10TH ED. (CLASS "R")	CODE STAMP	NO
LOCAL REGULATION	NO	WIND / SEISMIC CODE	UBC 97
FLUID	PROPANE	STYRENE	WIND EXPOSURE / VELOCITY (km/h)
DESIGN (INT.EXT.)	PRESS. barg	22/F.V.	6.8
TEMP. (°C)	120/85	SEISMIC IMPROVANCE FACTOR/RESPONSE FACTOR	1.25 / 3
STEAM OUT CONDITION	-	INSULATION (TYPE/THK.)	COLD/60 COLD/60
OPER. (IN/OUT)	PRESS. barg	3.813	4.5
TEMP. (°C)	1.24/1	15.2/5	FIRE PROOFING (mm)
CORROSION ALLOWANCE (mm)	3	3	TUBE TO TUBESHEET JOINT
JOINT EFFICIENCY (S/H)	1.0/1.0	1.0/1.0	NO. OF PASS
RADIOGRAPHY (S/H)	FULL/FULL	FULL/FULL	1(ONE) 4(FOUR)
HYDRO. TEST PRESS. (SHOP/FIELD)	barg	28.6/28.6	8.84/8.84
HYDRO. TEST TYPE	(U-90) NICE (B) (U-90) NICE (B)	WEIGHT	BUNDLE (KG)
PNEUM. TEST PRESS. barg	-	EMPTY (KG)	2,850
M.D.M.T. (°C)	-45	-29	OPER. (KG)
M.A.P (HOT & CORRODED) barg	22	6.8	FULL WATER (KG)
M.A.P (NEW & COLD) barg	22	6.8	SURFACE AREA/SHELL (M²)
P.W.H.T	NO	NO	VOLUME (M³)
IMPACT TEST	NO	NO	FLUID DENSITY (kg/m³)
S.R OF HEAD AFTER COLD FORMING	YES	YES	MEAN METAL TEMP. (°C)
			SHELL SIDE TUBE SIDE

NOZZLE LIST

NOZZLE MARK	Q'TY / 1 SET	SIZE (INCH)	FLANGE RATING	SCH.	SERVICE	H/EX. CL. PROJECTION	REINF. PAD TH'K	O.D.
S1	1	4"	ASME B16.5 300# WN.RF	120	SHELL SIDE INLET	SEE DWG.	12	220
S2	1	6"	ASME B16.5 300# WN.RF	80	SHELL SIDE OUTLET	675	12	300
T1	1	3"	ASME B16.5 150# WN.RF	80	CHANNEL SIDE INLET	SEE DWG.	10	190
T2	1	3"	ASME B16.5 150# WN.RF	80	CHANNEL SIDE OUTLET	SEE DWG.	10	190
D1	1	2"	ASME B16.5 300# WN.RF	160	SHELL SIDE DRAIN	SEE DWG.	-	-
D2	1	2"	ASME B16.5 300# WN.RF	160	OIL RECOVERY	SEE DWG.	-	-
LG1	1	2"	ASME B16.5 300# WN.RF	160	LEVEL GAUGE	SEE DWG.	-	-
LG2	1	2"	ASME B16.5 300# WN.RF	160	LEVEL GAUGE	SEE DWG.	-	-
PSV	1	3"	ASME B16.5 300# WN.RF	160	PRESSURE SAFETY VALVE	675	12	190
V	1	2"	ASME B16.5 300# WN.RF	t16.6	VENT	675	-	-
S3	1	2"	ASME B16.5 300# WN.RF	160	SHELL SPARE/PURGE	SEE DWG.	-	-

LEGEND

B.L. = BASE LINE
 C.L. = CENTER LINE
 M.D.M.T. = MIN. DESIGN METAL TEMPERATURE
 N. = NORMALIZED
 O.T.L. = OUTER TUBE LINE
 C.O.G. = CENTER OF GRAVITY
 T.O.G. = TOP OF GROUTING
 W.P. = WORKING POINT

CLIENT

پارس آف سائت
 صنعتی گودر افق

CONSULTING ENGINEER

PROJECT: **STYRENE PARK OFFSITE**

DRAWING TITLE: **GENERAL ARRANGEMENT DRAWING FOR CHILLER (EVAPORATOR)**

DRAWING NO.	REV.	SIZE	SCALE	SHEET
E1027-HSE-VD-ME-DWG-008	R1	A3	NTC	1 of 8

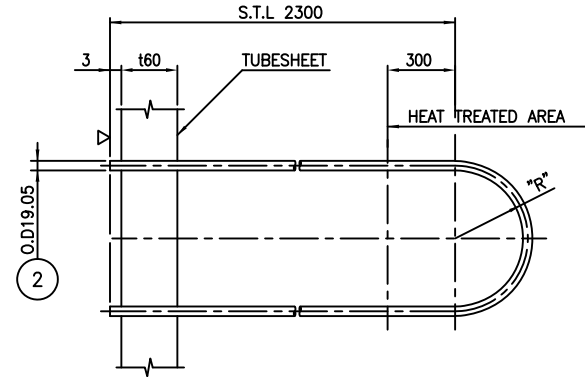
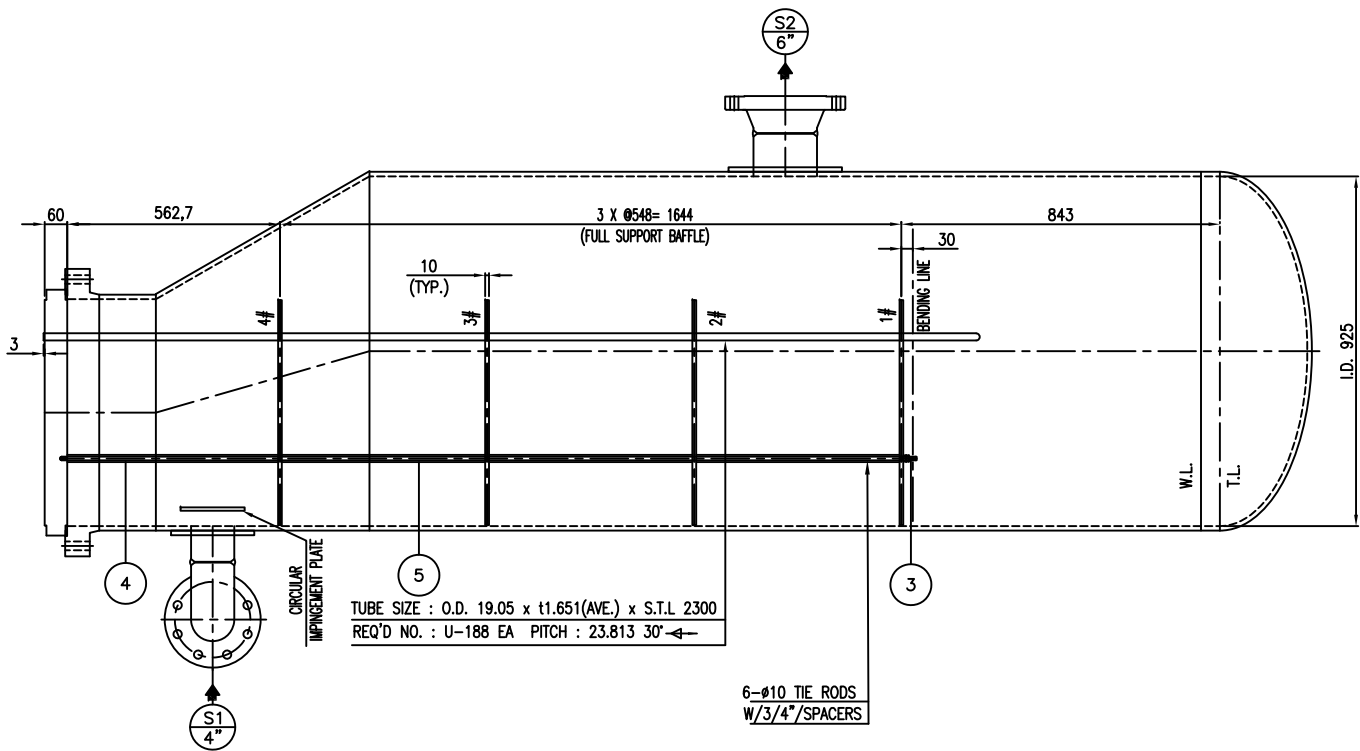

U-TUBE

NO.	"R"	"L"	Q'TY
1	35.72	4712.2	10
2	47.63	4749.6	10
3	59.53	4787.0	10
4	71.44	4824.4	10
5	83.35	4861.8	10
6	95.25	4899.3	10
7	107.16	4936.7	10
8	119.07	4974.1	10
9	130.98	5011.5	10
10	142.88	5048.9	10
11	154.79	5086.3	10
12	166.70	5123.7	10
13	178.60	5161.1	10
14	190.51	5198.5	10
15	202.42	5235.9	8
16	214.33	5273.3	10
17	226.23	5310.7	8
18	238.14	5348.1	8
19	250.05	5385.5	6
20	261.95	5422.9	6
21	273.86	5460.4	2

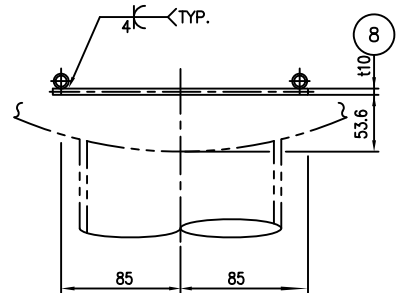
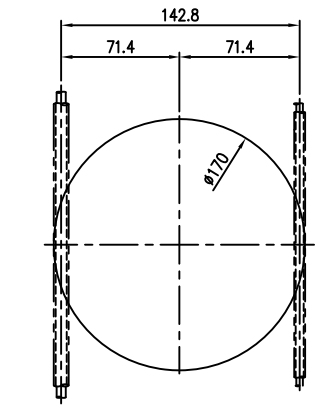

IMPINGEMENT PLATE

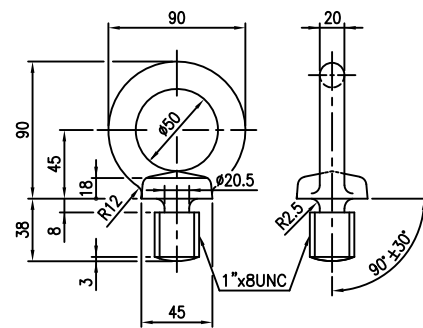

6 EYE BOLT

U-TUBE DIMENSION

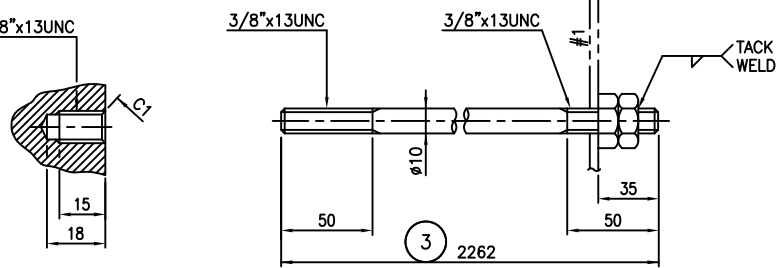
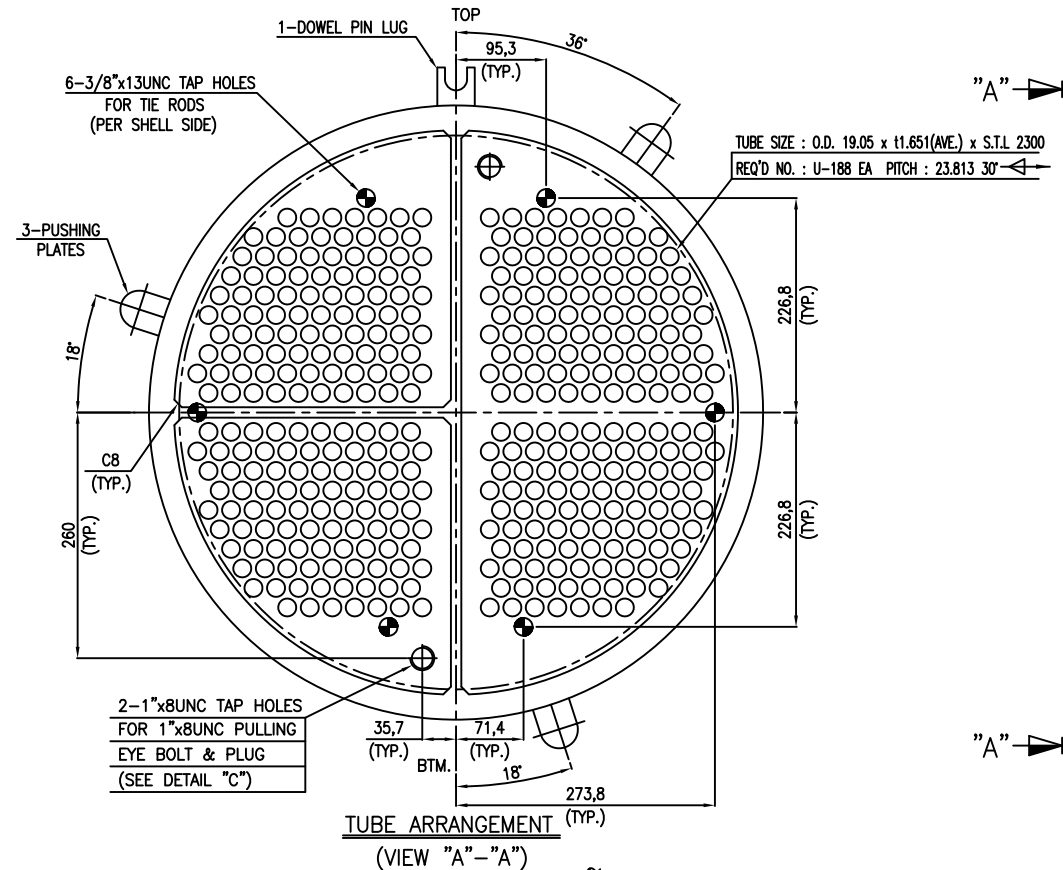

DETAIL "B"

TIE ROD & 2 NUTS

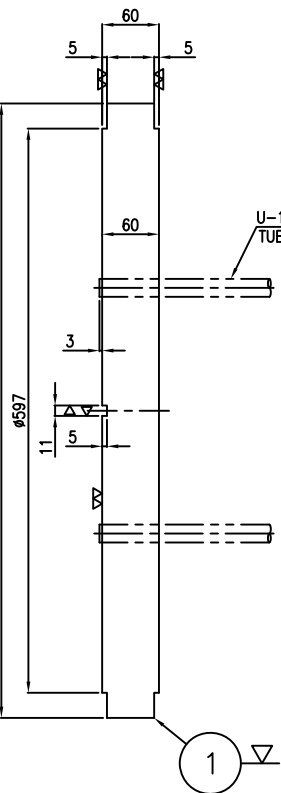

TUBESHEET DETAIL

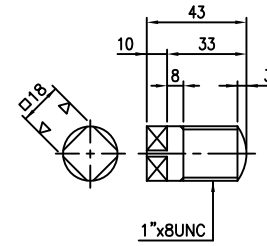

7 PLUG

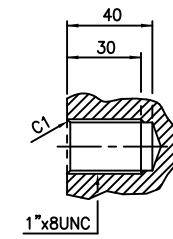

DETAIL "C"

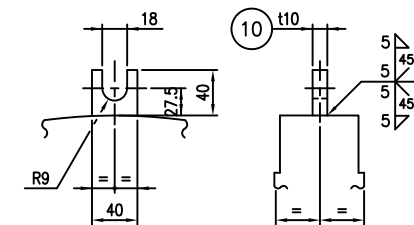

DOWEL PIN LUG

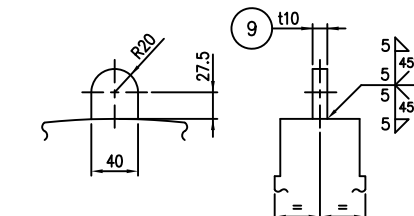

PUSHING PLATE

PART NO.	QTY	"L"
4	6	558
5	18	538

SPACER

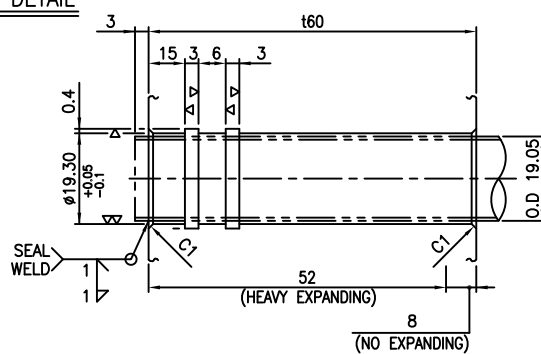

TUBE TO TUBESHEET JOINT



NOTES

1. UNLESS OTHERWISE NOTED ALL DIMENSIONS ARE IN MILLIMETERS.

*** FOR ONE SET**

NO	PART NAME	MATERIAL	REGULAR QUANTITY	SPARE QUANTITY	SPECIFICATION	REMARK
10	DOWEL PIN LUG	SA516-70M	1		t10 x 40 x 40	
9	PUSHING PLATE	SA283-C	3		t10 x 34 x 47.5	
8	IMPINGEMENT PLATE	SA516-70M	1		t10 x Ø170	
7	PLUG	304 S.S	2		1"x8UNC	
6	EYE BOLT	SA36	2		1"x8UNC	
5	SPACER	SA334-6	18		Ø19.05 x t1.651 x L538	
4	SPACER	SA334-6	6		Ø19.05 x t1.651 x L558	
3	TIE ROD & 2NUTS	SA36/SA194-2H	6SETS		3/8"x13UNC (R180) x L282	
2	TUBE	SA334-6	U-188		Ø19.05 x t1.651(AVE.) x L1230M	
1	TUBESHEET	SA350-LF2 CL.1N	1		t60x Ø650	

BILL OF MATERIAL

REV.	ISSUE DATE	DESCRIPTION	PREPARED	CHECKED	APPROVED
R0	06.27.2024	ISSUED FOR APPROVAL (IFA)	D.SH.	M.O.	A.M.

CLIENT

پتروشیمی توسعه پارک
صنعتی گوهر المی

CONSULTING ENGINEER

PROJECT: **STYRENE PARK OFFSITE**

DRAWING TITLE: **BUNDLE DETAIL DRAWING FOR CHILLER (EVAPORATOR) (2/2)**

DRAWING NO.	REV.	SIZE	SCALE	SHEET
EIO27-HSE-VD-ME-DWG-008	R0	A3	NTC	4 of 8

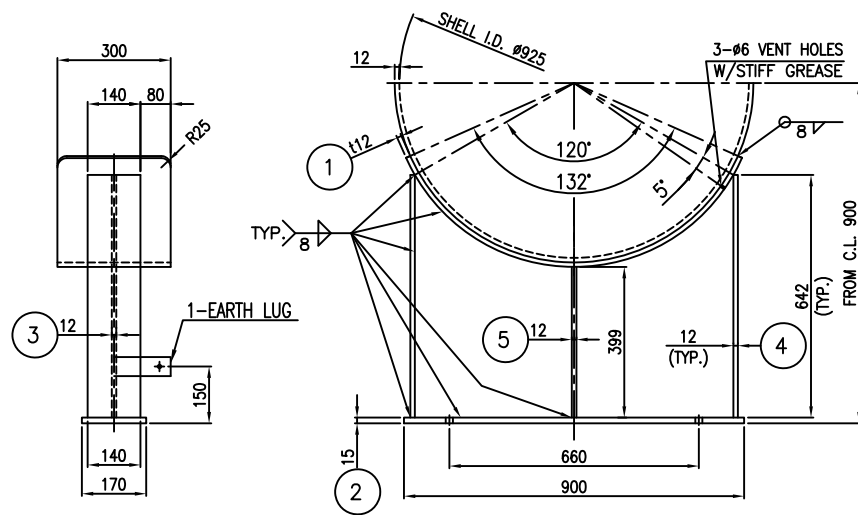

FIXED SIDE

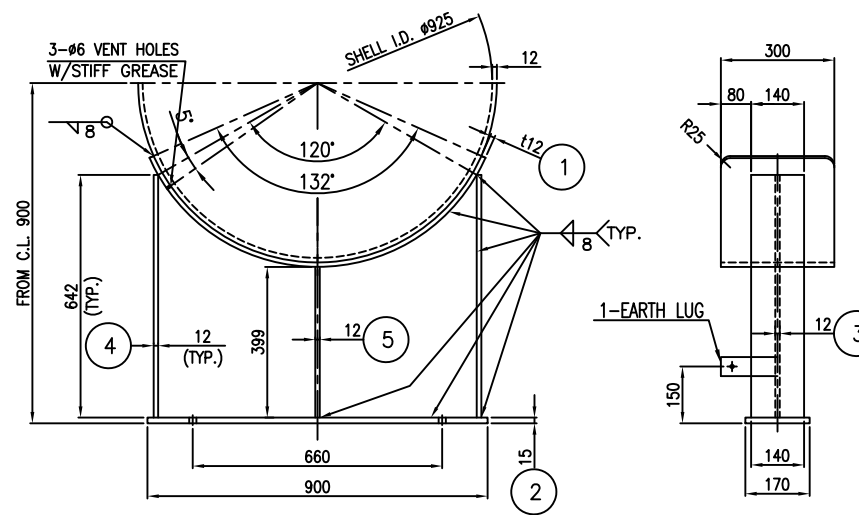

SLIDING SIDE

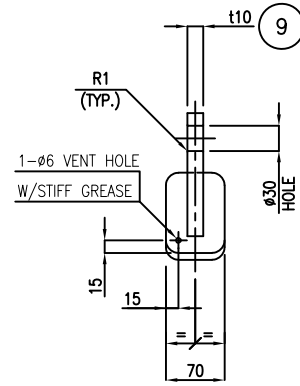
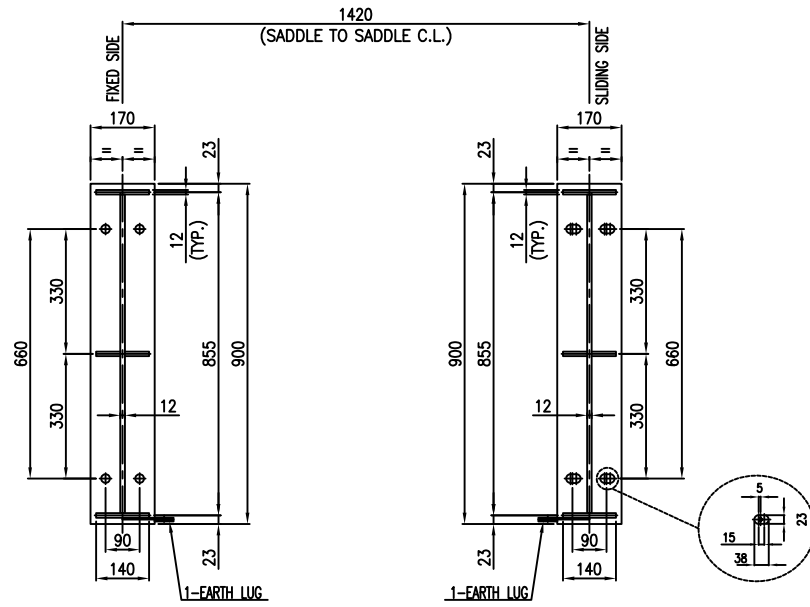

LIFTING LUG DETAIL
(FOR CHANNEL SIDE)

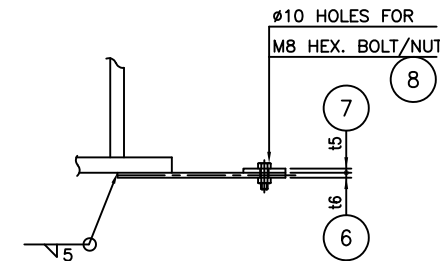
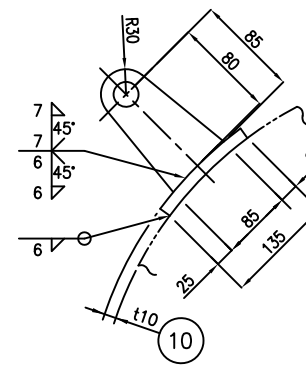

EARTH LUG

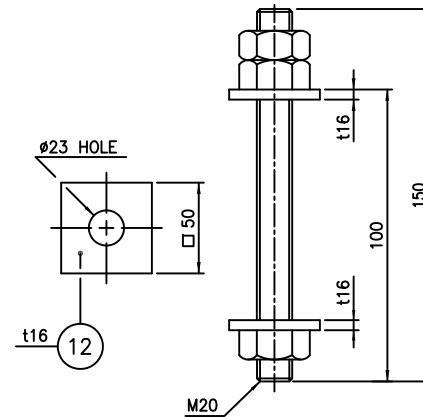

SETTING B/2NS/2W



NOTES
1. UNLESS OTHERWISE NOTED ALL DIMENSIONS ARE IN MILLIMETERS.
2. SINCE CABLE LUG IS TINNED COPPER, TINNED CARBON STEEL EARTH LUG.

FOR ONE SET					
PART NO.	PART NAME	MATERIAL	REGULAR QUANTITY	SPARE QUANTITY	REMARK
12	WASHER	SA283-C	32		M8 x 150 (NOT DP OR V)
11	SETTING BOLT/2NUTS	SA193-B7/SA194-2H	2SETS		M20 x 150 (NOT DP OR V)
10	REINF. PAD	SA516-70N	3		t12 x 70 x 135
9	LIFTING LUG	SA283-C	3		t20 x 85 x 122
8	HEX. BOLT/NUT	S.S. 304	2SETS		M8 x L25
7	COPPER PLATE	SEE NOTE "2"	2		t5 x 50 x 50
6	EARTH LUG	SA283-C	2		t6 x 50 x 150
5	SUPPORT RIB	SA283-C	4		t12 x 64 x 399
4	SUPPORT RIB	SA283-C	4		t12 x 140 x 642
3	WEB PLATE	SA283-C	2		t12 x 642 x 843
2	BASE PLATE	SA283-C	2		t15 x 170 x 900
1	WEAR PLATE	SA516-70N	2		t12 x 300 x 1107

BILL OF MATERIAL

REV.	ISSUE DATE	DESCRIPTION	PREPARED	CHECKED	APPROVED
R0	06.27.2024	ISSUED FOR APPROVAL (FA)	D.SH.	M.O.	A.M.

CLIENT



CONSULTING ENGINEER

PROJECT: STYRENE PARK OFFSITE

DRAWING TITLE: SADDLE DETAIL DRAWING FOR CHILLER (EVAPORATOR)

DRAWING NO.	REV.	SIZE	SCALE	SHEET
E1027-HSE-VD-ME-DWG-008	R0	A3	NTC	5 of 8

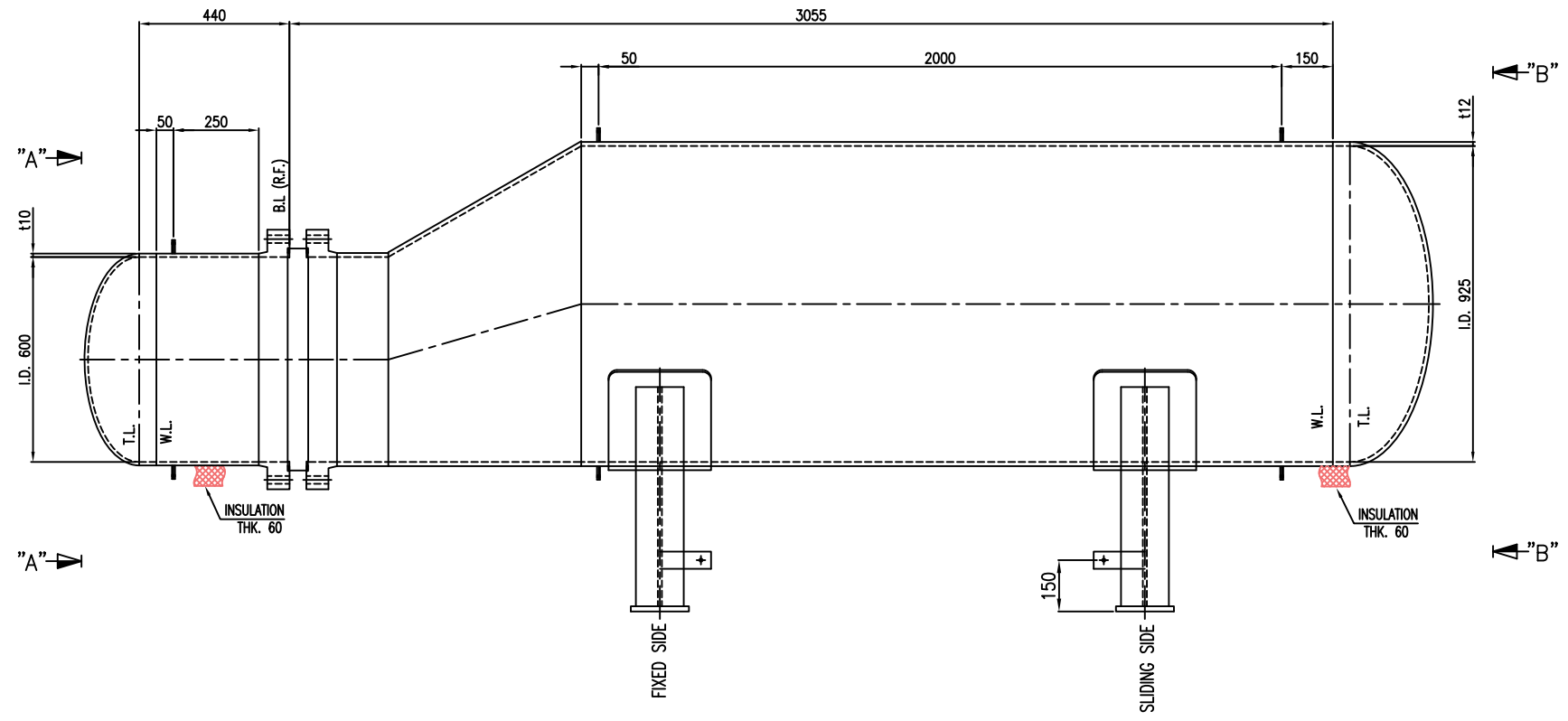

ELEVATION VIEW

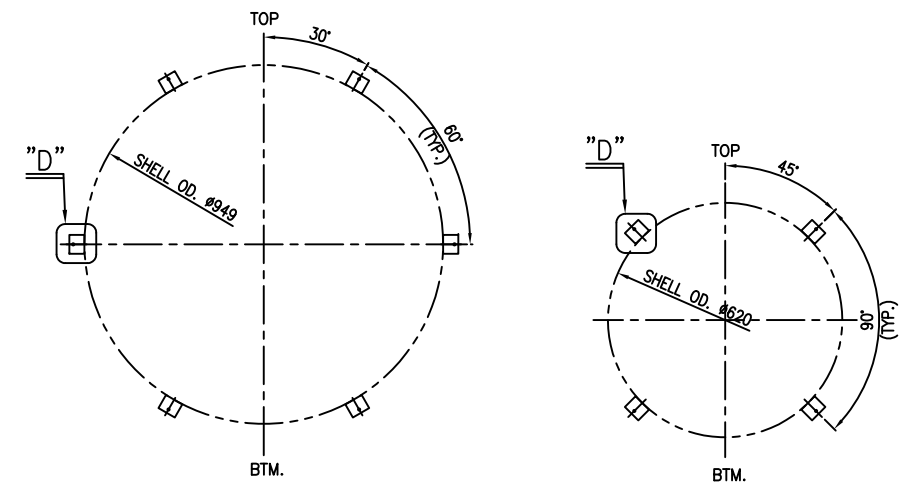

VIEW "B"- "B"

VIEW "A"- "A"

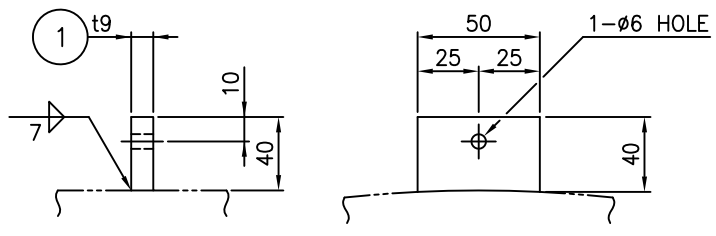

DETAIL "D"

NOTES
1. UNLESS OTHERWISE NOTED ALL DIMENSIONS ARE IN MILLIMETERS.

* FOR ONE SET

PART NO.	PART NAME	MATERIAL	REGULAR QUANTITY	SPARE QUANTITY	SPECIFICATION	REMARK
1	INSUL. SUPT CLIP	SAS16-70N	16		19 x 40 x 50	

BILL OF MATERIAL

REV.	ISSUE DATE	DESCRIPTION	PREPARED	CHECKED	APPROVED
R0	06.27.2024	ISSUED FOR APPROVAL (IFA)	D.SH.	M.O.	A.M.

CLIENT

 CONSULTING ENGINEER

PROJECT: **STYRENE PARK OFFSITE**

DRAWING TITLE: **INSULATION CLIP DRAWING FOR CHILLER (EVAPORATOR)**

DRAWING NO.	REV.	SIZE	SCALE	SHEET
EI027-HSE-VD-ME-DWG-008	R0	A3	NTC	7 of 8

