



پتروشیمی توسعه پارک
صنعتی کوهر افق

Toase-eh Park Sanati Gohar Ofogh
Petrochemical Co.

**CONCEPTUAL, BASIC and DETAIL DESIGN
ENGINEERING OF STYRENE PARK OFFSITE**



BINA EPC Contractor Co.
(Executor of Oil, Gas, Petrochemical & Power Industries)

Document Title : Process Duty Specification For Activated Carbon
Package

Document No.: EI027-000-ED-PR-SPC-500

Rev. R1

Page 1 of 10

STYRENE PARK OFFSITE

Document Title:

PROCESS DUTY SPECIFICATION FOR ACTIVATED CARBON PACKAGE

Rev.	Issued Date	DESCRIPTION	PREPARED	CHECKED	APPROVED
R1	11.08.2020	ISSUED FOR APPROVAL (IFA)	M.Abbasian	S.Behniafar	R.Memar
R0	09.05.2020	ISSUED FOR COMMENT (IFC)	M.Abbasian	S.Behniafar	R.Memar



پتروشیمی توسعه پارک
صنعتی کوهر افق

Toase-eh Park Sanati Gohar Ofogh
Petrochemical Co.

**CONCEPTUAL, BASIC and DETAIL DESIGN
ENGINEERING OF STYRENE PARK OFFSITE**



BINA EPC Contractor Co.
(Executor of Oil, Gas, Petrochemical & Power Industries)

Document Title : Process Duty Specification For Activated Carbon
Package

Document No.: EI027-000-ED-PR-SPC-500

Rev. R1

Page 2 of 10

REVISION RECORD SHEET

Page	Revisions							Page	Revisions						
	R0	R1	R2	R3	R4	R5	R6		R0	R1	R2	R3	R4	R5	R6
1	X							41							
2	X							42							
3	X							43							
4	X							44							
5	X							45							
6	X							46							
7	X	X						47							
8	X							48							
9	X							49							
10	X							50							
11								51							
12								52							
13								53							
14								54							
15								55							
16								56							
17								57							
18								58							
19								59							
20								60							
21								61							
22								62							
23								63							
24								64							
25								65							
26								66							
27								67							
28								68							
29								69							
30								70							
31								71							
32								72							
33								73							
34								74							
35								75							
36								76							
37								77							
38								78							
39								79							
40								80							





	Toase-eh Park Sanati Gohar Ofogh Petrochemical Co. CONCEPTUAL, BASIC and DETAIL DESIGN ENGINEERING OF STYRENE PARK OFFSITE		
	Document Title : Process Duty Specification For Activated Carbon Package		
	Document No.: EI027-000-ED-PR-SPC-500	Rev. R1	

Table of Contents

1.	GENERAL INTRODUCTION _____	4
1.1	Introduction _____	4
1.2	Scope _____	4
2.	APPLICABLE CODES, STANDARDS, SPECIFICATIONS, ABBREVIATIONS AND SITE ENVIRONMENTAL CONDITIONS & UTILITIES _____	5
2.1	Precedence of Codes, Standards and Specifications _____	5
2.2	International Codes and Standards _____	5
2.3	Associated Project Documentation _____	5
2.4	Site Environmental Conditions & Utilities _____	5
2.5	Abbreviation _____	6
3.	SERVICE / UNIT DESCRIPTION _____	6
4.	DESIGN DATA _____	7
4.1	Performance of the unit _____	7
4.2	Fluid characteristics / Physical and chemical data _____	7
4.3	Noise and vibration _____	7
5.	SCOPE OF SUPPLY _____	8
6.	LIMITS OF SUPPLY _____	9
6.1	Battery limits _____	9
7.	GUARANTEES _____	10
8.	DATA / DOCUMENTS TO BE SUPPLIED BY VENDOR _____	10

 <p>پتروشیمی توسعه پارک صنعتی گوهر افق</p>	<p>Toase-eh Park Sanati Gohar Ofogh Petrochemical Co.</p> <p>CONCEPTUAL, BASIC and DETAIL DESIGN ENGINEERING OF STYRENE PARK OFFSITE</p>		 <p>BINA EPC Contractor Co. (Executor of Oil, Gas, Petrochemical & Power Industries)</p>
	<p>Document Title : Process Duty Specification For Activated Carbon Package</p>		
	<p>Document No.: EI027-000-ED-PR-SPC-500</p>		<p>Rev. R1</p>

1. GENERAL INTRODUCTION

1.1 Introduction

Creation and development of chain units of Styrene Monomer is the mission of Gohar Ofogh Industrial Park. This Company joint investment of 4 companies including JPC, Assaluyeh Sadaf Chemical, Kimia Sanaye Dalahoo and Entekhab Group and is located in Assaluyeh.

Feed and utility lines and network construction, Styrene Monomer tank construction, Peroxide and its sidelong equipment warehouse are among this company's missions.

Some of the ongoing Projects of this company are:

- ABS-Rubber project
- ESBR project
- EPS project
- Poly Styrene



1.2 Scope

This General Specification defines the minimum technical requirements for bulk materials to be installed in "STYRENE PARK OFFSITE".

MANUFACTURER/SUPPLIER shall provide a complete system/equipment designed and fabricated in accordance with high standards of engineering, workmanship and suitable for intended service as described in this General Specification.

Any omission in this General Specification shall not relieve (EPC) CONTRACTOR from his obligation to supply a fully workable system intended for the service as specified.

Any deviation from this General Specification must be approved, in writing, by OWNER. Such written approval must be obtained prior to the commencement of any work, which constitutes such deviation.

 <p>پتروشیمی توسعه پارک صنعتی گوهر افق</p>	<p>Toase-eh Park Sanati Gohar Ofogh Petrochemical Co.</p> <p>CONCEPTUAL, BASIC and DETAIL DESIGN ENGINEERING OF STYRENE PARK OFFSITE</p>		 <p>BINA EPC Contractor Co. (Executor of Oil, Gas, Petrochemical & Power Industries)</p>
	<p>Document Title : Process Duty Specification For Activated Carbon Package</p>		
	<p>Document No.: EI027-000-ED-PR-SPC-500</p>		<p>Rev. R1</p>

Any unresolved conflicts between this General Specification and International Standards and Codes shall be resolved by (EPC) CONTRACTOR and shall be submitted to OWNER in writing.

2. APPLICABLE CODES, STANDARDS, SPECIFICATIONS, ABBREVIATIONS AND SITE ENVIRONMENTAL CONDITIONS & UTILITIES

2.1 Precedence of Codes, Standards and Specifications

It is VENDOR's responsibility to inform PURCHASER of any deviations from, or exceptions to, the listed codes, standards and specifications. PURCHASER will take non-listing of exceptions or deviations by VENDOR as being in full compliance with the codes, standards and specifications listed herein.

If there is a conflict between the various codes, standards and specifications, the VENDOR shall seek COMPANY's final interpretation and approval prior to the execution of work.

The latest edition of the codes and standards listed in sections 2.2 shall be used.

2.2 International Codes and Standards

According to manufacturer contractor.

2.3 Associated Project Documentation

EI027-000-ED-PR-PFD-501	PFD For Styrene (Inside Park Styrene Area)
EI027-000-ED-PR-PID-522	P&ID For Styrene Storage Tank

2.4 Site Environmental Conditions & Utilities

The Equipment shall be suitable for outdoor installation on offshore saline atmosphere at the following operation conditions:



پتروشیمی توسعه پارک
صنعتی کوهر افق

Toase-eh Park Sanati Gohar Ofogh
Petrochemical Co.

**CONCEPTUAL, BASIC and DETAIL DESIGN
ENGINEERING OF STYRENE PARK OFFSITE**



BINA EPC Contractor Co.
(Executor of Oil, Gas, Petrochemical & Power Industries)

Document Title : Process Duty Specification For Activated Carbon
Package

Document No.: EI027-000-ED-PR-SPC-500

Rev. R1

Page 6 of 10

Outdoor Conditions

Max. Ambient Design Temperature.	85 °C
Expected Extreme Temperature	52 °C
Min. Ambient Temperature.	5 °C
Max. Relative Humidity	80 %
Min. Relative Humidity	65 %



2.5 Abbreviation

PK	:	Package
VOC	:	Volatile Organic Compound
NFPA	:	National Fire Protection Association
P&ID	:	Pipe and Instrument Drawing

3. SERVICE / UNIT DESCRIPTION

Item	:	PK-0002A/B
Service	:	VOC abatement from styrene storage tank effluent
Number of units	:	2
Type	:	activated carbon drums

Polluted air vented from the styrene storage tanks TK-0001A/B, is diluted with air and sucked by the blower B-0001A~D. The effluent shall be properly routed to two rows of activated carbon drums for each unit, working in series for minimization of styrene emission.

 <p>پتروشیمی توسعه پارک صنعتی گوهر افق</p>	<p>Toase-eh Park Sanati Gohar Ofogh Petrochemical Co.</p> <p>CONCEPTUAL, BASIC and DETAIL DESIGN ENGINEERING OF STYRENE PARK OFFSITE</p>		 <p>BINA EPC Contractor Co. (Executor of Oil, Gas, Petrochemical & Power Industries)</p>
	<p>Document Title : Process Duty Specification For Activated Carbon Package</p>		
	<p>Document No.: EI027-000-ED-PR-SPC-500</p>		<p>Rev. R1</p>

4. DESIGN DATA

4.1 Performance of the unit

Each row of activated carbon drums shall be sized for the following flowrate

Operating flowrate: 1080 Nm³/h

Design flowrate: 1188 Nm³/h

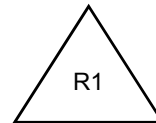

4.2 Fluid characteristics / Physical and chemical data

Composition: air / styrene

Max VOC concentration: styrene 3.5 gr/Nm³

MW styrene: 104.2 kmol/kg

Operating pressure: Atm (norm) / 0.07 barg max operating / 0.1 bar g (max in case of upset)

Design pressure: 0.1 barg

Operating temperature: Amb

Design temperature: 85°C

Max ΔP: 0.02 bar (at design flowrate)

Risk phrases: R10 (Flammable), R20 (Harmful by inhalation), R36/38 (Irritat. for eyes and skin)

Classification as per NFPA 704

Health Hazard Classification: 2

Fire Hazard Classification: 3

Reactivity Hazard Classification: 2

Material : Vendor's standard

4.3 Noise and vibration

Admitted noise level : the sound pressure level shall not exceed 85 dB(A), without any positive tolerance, at one (1) meter from the equipment.



پتروشیمی توسعه پارک
صنعتی گوهر افق

Toase-eh Park Sanati Gohar Ofogh
Petrochemical Co.

**CONCEPTUAL, BASIC and DETAIL DESIGN
ENGINEERING OF STYRENE PARK OFFSITE**



BINA EPC Contractor Co.
(Executor of Oil, Gas, Petrochemical & Power Industries)

Document Title : Process Duty Specification For Activated Carbon
Package

Document No.: EI027-000-ED-PR-SPC-500

Rev. R1

Page 8 of 10

5. SCOPE OF SUPPLY

Activated carbon characteristics are reported in the following table:

Number of units	4, arranged in two rows for each package (the number of drums shall be confirmed by vendor)
Type	to be defined by Vendor
Vessel Material	Vendor's standard
Dimensions	Vendor's standard
Connections	6" (150#, RF) for inlet/outlet (to be confirmed by Vendor). The nozzles shall be located on the side of the vessel drum to facilitate handling operations.
Accessories included in the supply	Vendor to provide nozzles for inlet / outlet joining of each drum. Activated carbon vessel shall be equipped with eyebolts for the lifting with hook and with pallet for the handling with forklifts. Grounding and electric continuity shall be ensured.
Target for emission (at design flowrate and maximum VOC concentration)	VOC < 50 mg/Nm ³ (1)



پتروشیمی توسعه پارک
صنعتی گوهر افق

Toase-eh Park Sanati Gohar Ofogh
Petrochemical Co.
**CONCEPTUAL, BASIC and DETAIL DESIGN
ENGINEERING OF STYRENE PARK OFFSITE**



BINA EPC Contractor Co.
(Executor of Oil, Gas, Petrochemical & Power Industries)

Document Title : Process Duty Specification For Activated Carbon
Package

Document No.: EI027-000-ED-PR-SPC-500

Rev. R1

Page 9 of 10



6. LIMITS OF SUPPLY

6.1 Battery limits

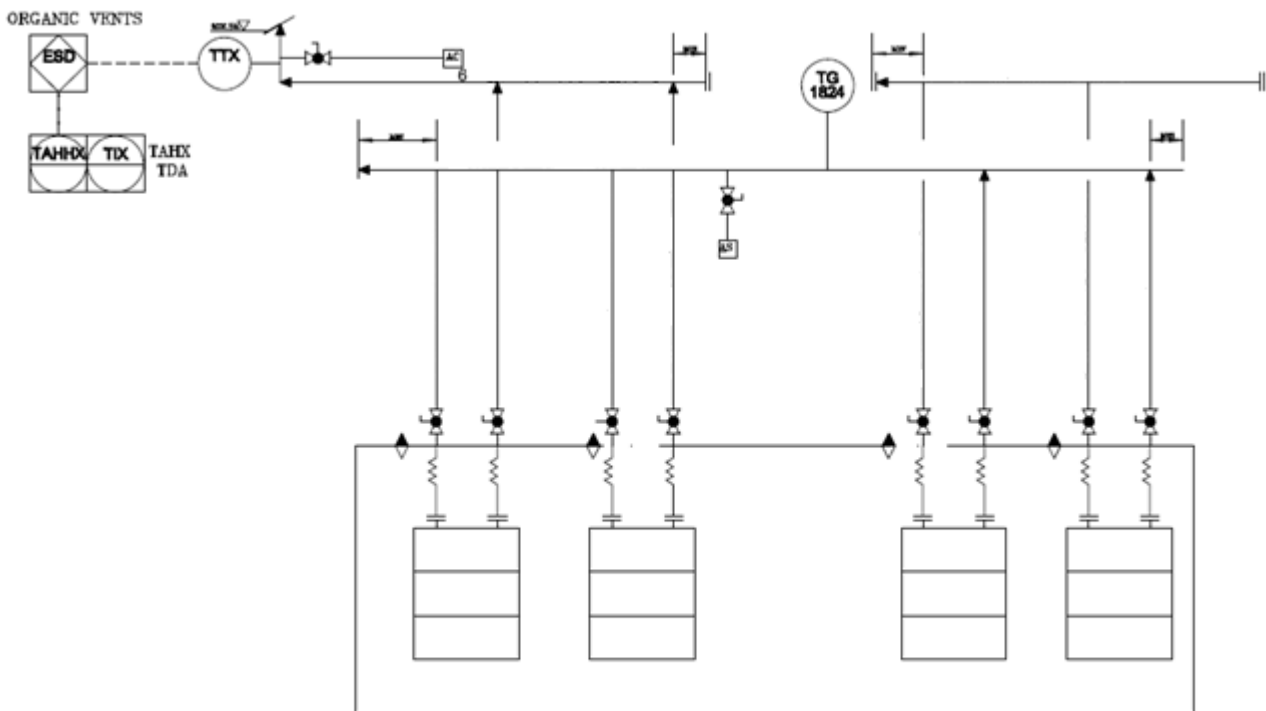
Vendor's scope of work will include equipment, included in the following battery limits specification:



PK-0002

 <p>پتروشیمی توسعه پارک صنعتی گوهر افق</p>	<p>Toase-eh Park Sanati Gohar Ofogh Petrochemical Co.</p> <p>CONCEPTUAL, BASIC and DETAIL DESIGN ENGINEERING OF STYRENE PARK OFFSITE</p>		 <p>BINA EPC Contractor Co. (Executor of Oil, Gas, Petrochemical & Power Industries)</p>
	<p>Document Title : Process Duty Specification For Activated Carbon Package</p>		
	<p>Document No.: EI027-000-ED-PR-SPC-500</p>		<p>Rev. R1</p>

7. GUARANTEES

Vendor shall be responsible for the process and mechanical performances as defined in scope of supply.

8. DATA / DOCUMENTS TO BE SUPPLIED BY VENDOR

Vendor shall provide the following data:

- styrene adsorption isotherm curve at 30°C/50°C/100°C
- general description of the unit and its operation
- overall package plot (views, plan)
- items list
- item's data sheets
- overall dimensions of every item, static and dynamic load, performances
- package P&ID
- layout
- certifications and tests including material certifications (if necessary)
- operating manual
- recommended interlocks sequences (if any) and safety procedures description.