



DEHDASHT PETROCHEMICAL INDUSTRY COMPANY
DEHDASHT HIGH DENSITY POLYETHYLENE PROJECT



Contract No.: DPIC/98-12	DOCUMENT TITLE: Filter Dryer Drawing	POI: IFA	Rev.: D0
	DOCUMENT No: DPIC9812-000-VD-1002-ME-DWG-0025	Sheet 1 of 4	

Filter Dryer Drawing (F-PK6101-2)

PURCHASER'S COMMENT/APPROVAL STATUS						Purchaser: NARGAN
1	AP: Approved (Released for Manufacturing)					Requisition No.: DPIC98-12-001-000-ME-MR-4150-0001-D1
2	AN: Approved With Minor Comments (Fabrication may Proceed)					
3	NF: Approved With Comments (Fabrication not Proceed)					
4	RJ: Rejected					Item No. (Tag No.): PK-6101
5	NR: Not be Returned					
Date:	15.01.2022	Signature:	A.AB			Vendor Doc. No.: DPIC9812-000-VD-1002-ME-DWG-0025-D0
						
D0	03-JAN.-22	IFA	F.SARLAK	M.NAZARSHOAR	DR.A.NEJATI	
REV.	DATE ISSUE	Purpose of Issue	PREPARED	CHECKED	APPROVED	



DEHDASHT PETROCHEMICAL INDUSTRY COMPANY
DEHDASHT HIGH DENSITY POLYETHYLENE PROJECT



Contract No.: DPIC/98-12	DOCUMENT TITLE: Filter Dryer Drawing	POI: IFA	Rev.: D0
	DOCUMENT No: DPIC9812-000-VD-1002-ME-DWG-0025	Sheet 2 of 4	

TABULATION OF REVISED PAGES

Page	Rev-D0	Rev-D1	Rev-D2	Rev-D3	Rev-D4
1	x				
2	x				
3	x				
4	x				
5					
6					
7					
8					
9					
10					
11					
12					
13					
14					
15					
16					
17					
18					
19					
20					
21					
22					
23					
24					
25					
26					
27					
28					
29					
30					
31					
32					
33					
34					
35					

Page	Rev-D0	Rev-D1	Rev-D2	Rev-D3	Rev-D4
36					
37					
38					
39					
40					
41					
42					
43					
44					
45					
46					
47					
48					
49					
50					
51					
52					
53					
54					
55					
56					
57					
58					
59					
60					
61					
62					
63					
64					
65					
66					
67					
68					
69					
70					

This document is the property of DPIC. Any unauthorized attempt to reproduce it, in any form, is strictly prohibited.

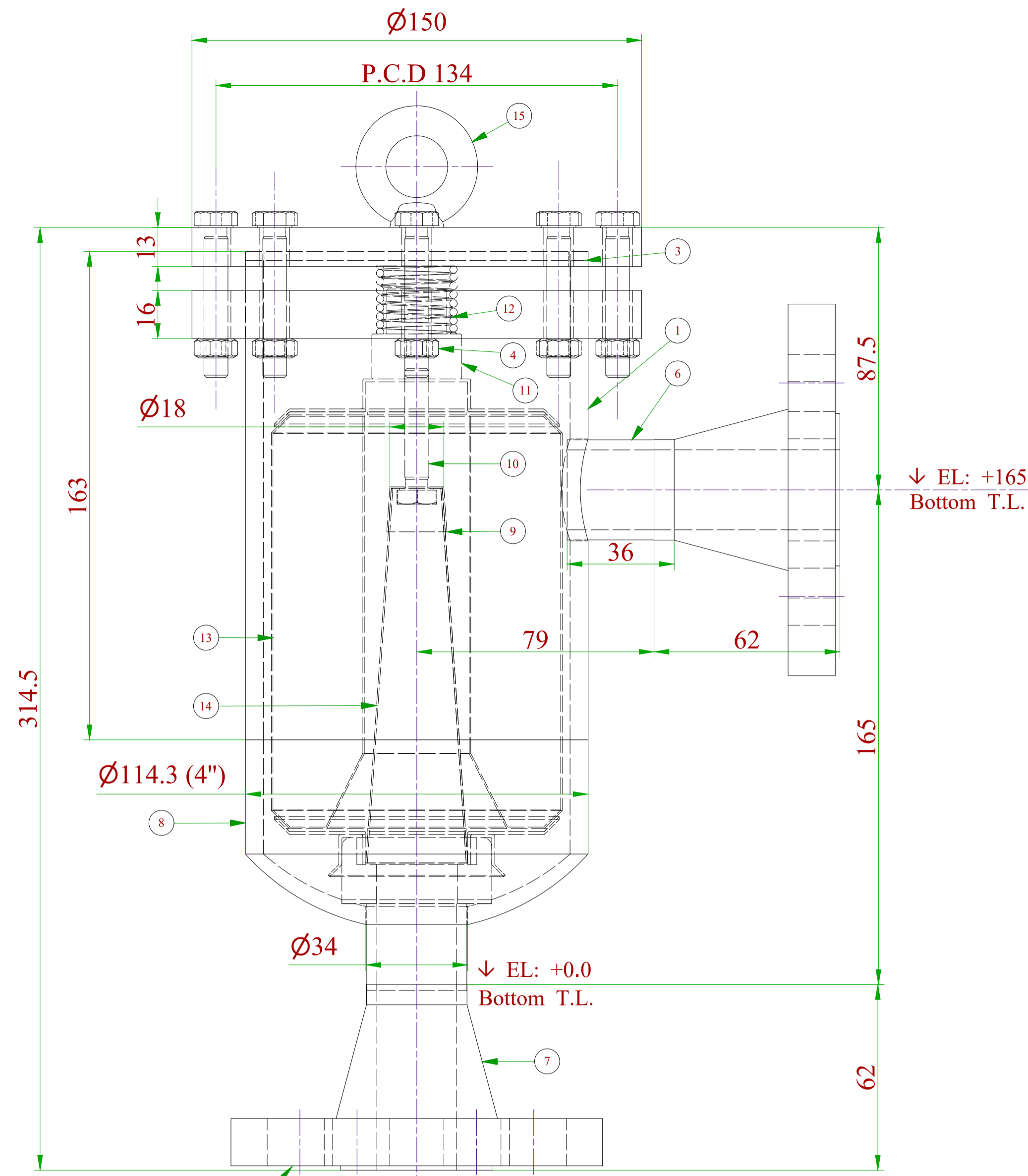

Propylene Filter Dryer - Front View

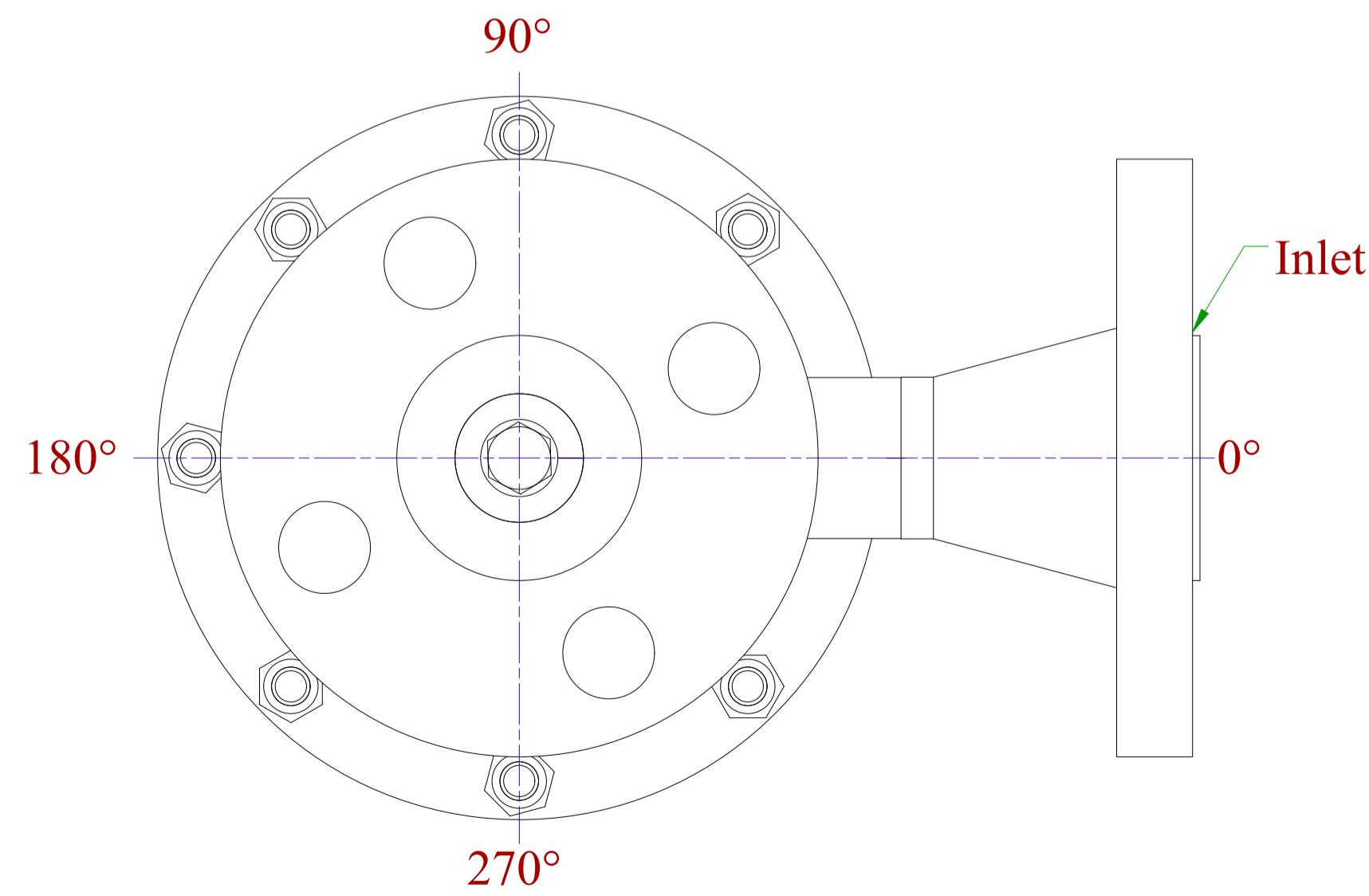

Propylene Filter Dryer - Top View

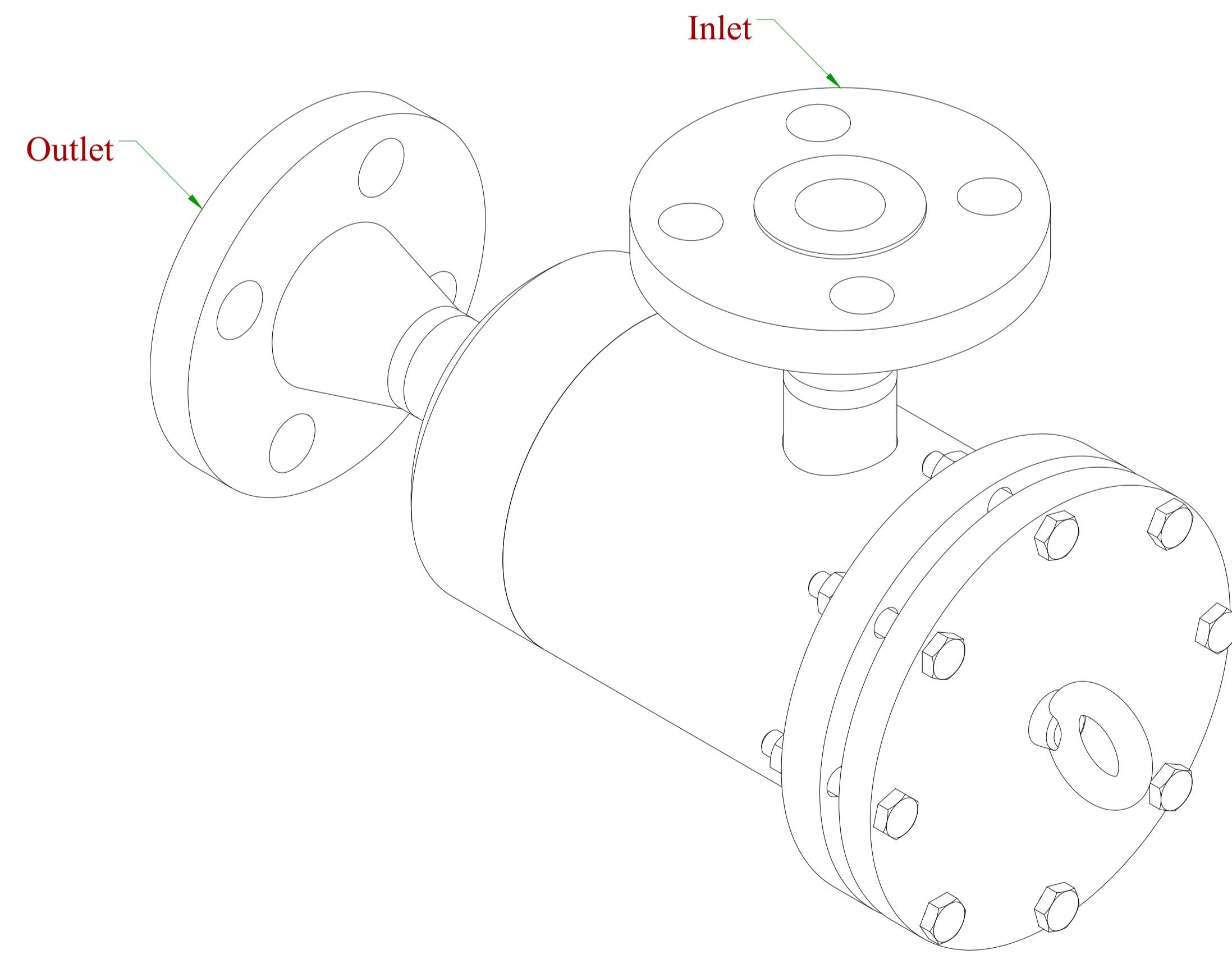

Propylene Filter Dryer - Isometric View

REFERENCES DOCUMENT

NOTES

SPECIFICATION

9	CORROSION ALLOWANCE	3 mm
8	VISCOSITY	0.06 cP
7	DENSITY	461 kg/m ³
6	PRESSURE VACUUM	1.01 BarA
5	PRESSURE OPERATING	18.6 BarG
4	PRESSURE DESIGN	23 BarG
3	OPERATING TEMPERATURE	48.5 C
2	DESIGN TEMPERATURE	-45/135 C
1	FLUID	PROPYLENE
Num	ITEM	DESCRIPTION

Process Data

Pos.	ITEM	Description	Material	Qty	Total Weight	Remark
16	End Flange	---	A516 GR.70	1	0.852 kg	Refer to sheet 4
15	Metric Lifting Eyes	ANSI B18.15.1M - M8x13	A193GR.B8	1	0.065 kg	
14	Semi Cone Strainer	---	S.S.304	1	0.302 kg	Refer to sheet 4
13	Dryer Core	By Vendor	---	1	By Vendor	
12	Compress Spring	L ₀ =28mm, Wire Dia. 2.5mm Diameter:22mm	S.S. 304	1	0.024 kg	
11	Bush	---	S.S. 304	1	0.108 kg	Refer to Sheet 4
10	Hex-Head Bolt	DIN 933 - M8	Steel, Mild	1	0.021 kg	
9	Strainer Cap	---	---	1	0.004 kg	Refer to Sheet 4
8	End Cap	BW Cap ,Sch40,4", ANSI B16.9	A420 WPL6	1	1.6 kg	
7	Nozzle Flange	WN,ANSI B16.5,1",CI 300	SA350 LF2,CL.1	2	3.21 kg	
6	Nozzle Pipe	Pipe, Sch.40,1",ANSI B36.10	SA 333 GR.6	1	0.074 kg	
5	Hex-Head Bolt	DIN 933 - M8 x 50	A193GR.B8	8	0.203 kg	
4	Hex Nut	DIN 934 - M8	A194GR.2H	8	0.043 kg	
3	Seal Ring	V/#7020	PTFE	1	0.013 kg	Refer to Sheet 4
2	Blind Flange	Modified Flange	A516 GR.70	1	12.3 kg	Refer to Sheet 4
1	Shell	Pipe,Sch.40,4",ANSI B36.10	SA 333 GR.6	1	2.6 kg	

PARTS LIST

CLIENT: MC CONTRACTOR:

This document is the property of DPIC. Any unauthorized attempt to reproduce it, in any form, is strictly prohibited.

PROJECT TITLE:
DEHDASHT PETROCHEMICAL INDUSTRY COMPANY
DEHDASHT HIGH DENSITY POLYETHYLENE PROJECT

DRAWING TITLE:
FILTER DRYER DRAWING

DOCUMENT No: DPIC9812-000-VD-1002-ME-DWG-0025
SC: A1
SIZE: A1

Proj. Code	Area No.	VD	Material Code	PO No.	Disc. Code	Doc. Type	Serial No.	Rev.	Sheet No.
									3 of 4

PURCHASER'S COMMENT/APPROVAL STATUS: 1. AP: Approved (Released for Manufacturing); 2. AM: Approved With Minor Comments (Fabrication may Proceed); 3. NF: Approved With Comments (Fabrication not Proceeded); 4. RJ: Rejected; 5. NR: Not to be Returned.
PURCHASER: _____
REQUISITION NO.: _____
ITEM NO. (TAG NO.): F-PK6101-2
Date: XX.XX.XX Signature: _____
VENDOR DOC. NO.: _____

DO	02-01-2022	ISSUE FOR APPROVAL	F.SARLAK	M.NAZARSHAH	D.RA.NEJATI
REV	DATE	DESCRIPTION	PREP'D	CHK'D	APP'D



KASRAVAND CO.

Color	Width
RED	0.10
YEL	0.20
GRN	0.30
CYA	0.40
BLU	0.50
MAG	0.60
WHY	0.20
8	0.10
9	0.10
11	0.10
30	0.10
40	0.10
54	0.10
60	0.10
100	0.10
112	0.10
140	0.10
230	0.10

NOTES

1. Strainer Mesh shall be Finalized by Vendor.

SPECIFICATION

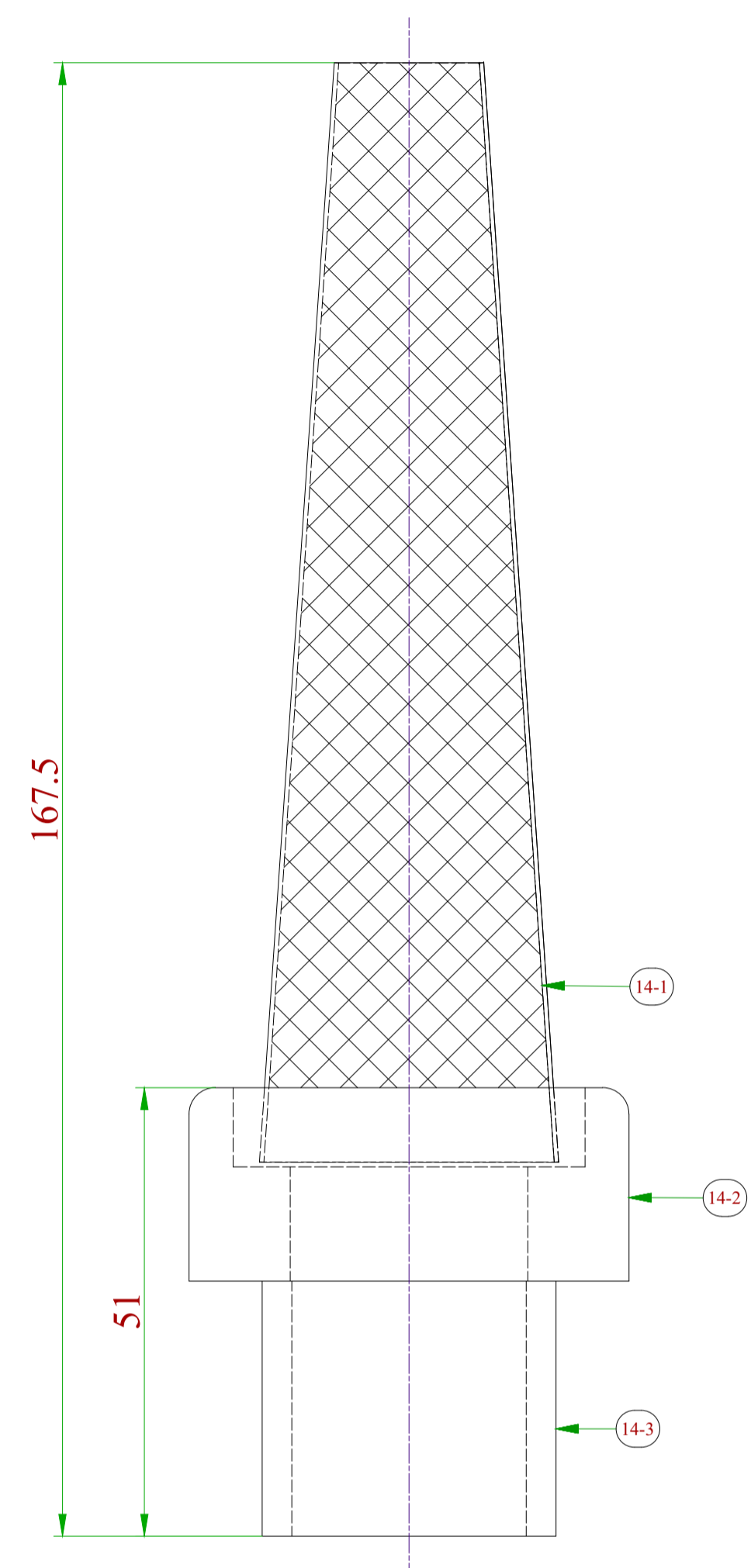

Pos. 14 : Semi Cone Strainer - Front View

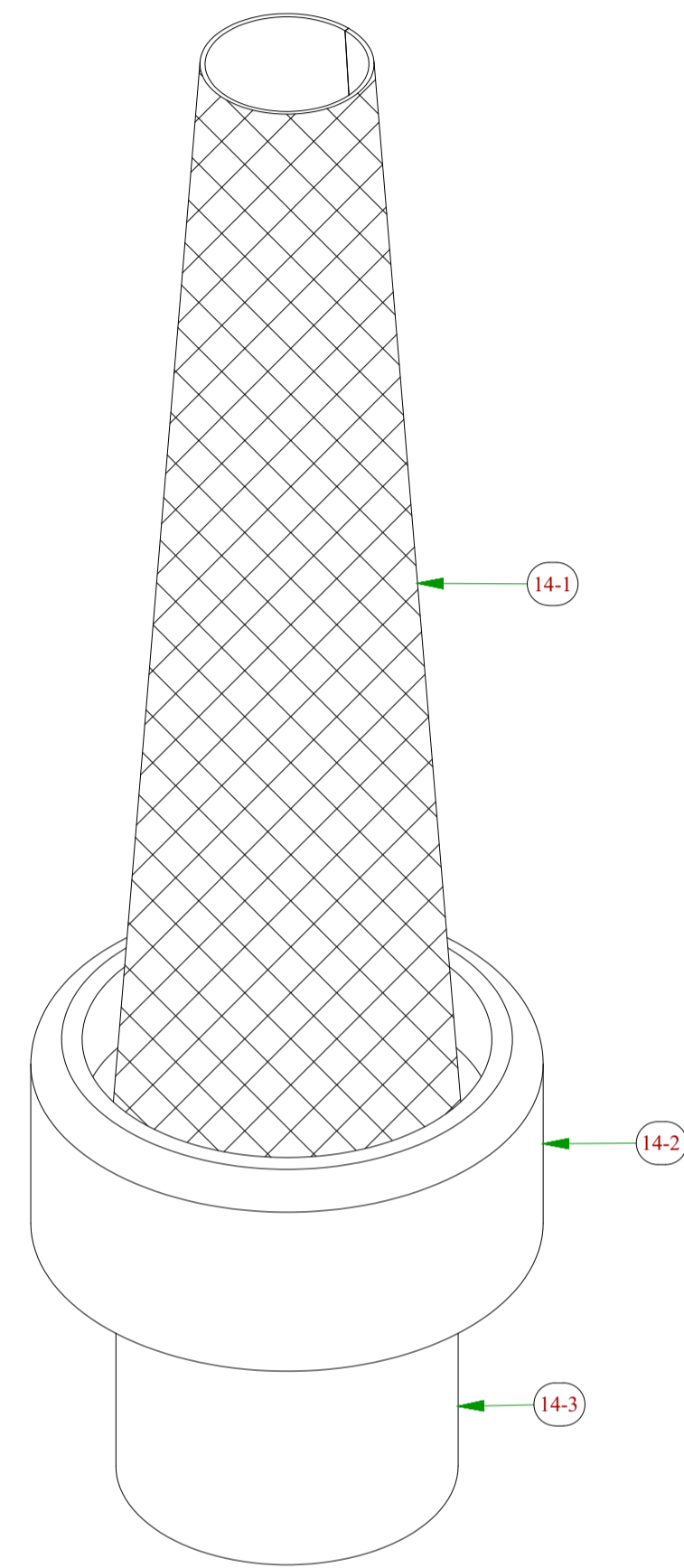

Propylene Filter Dryer - Isometric View

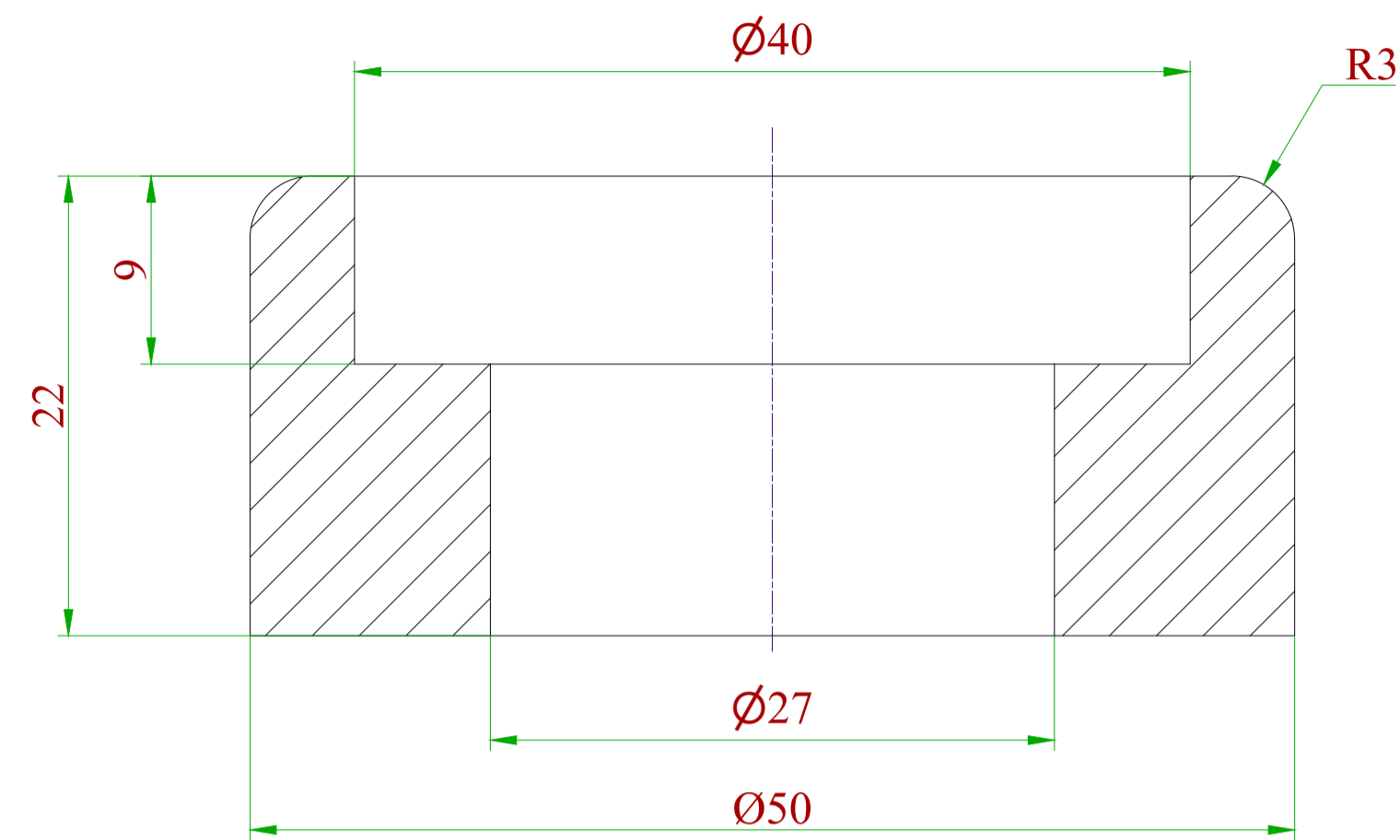

Pos. 14-2 : Spacer View
Scale : (2 : 1)

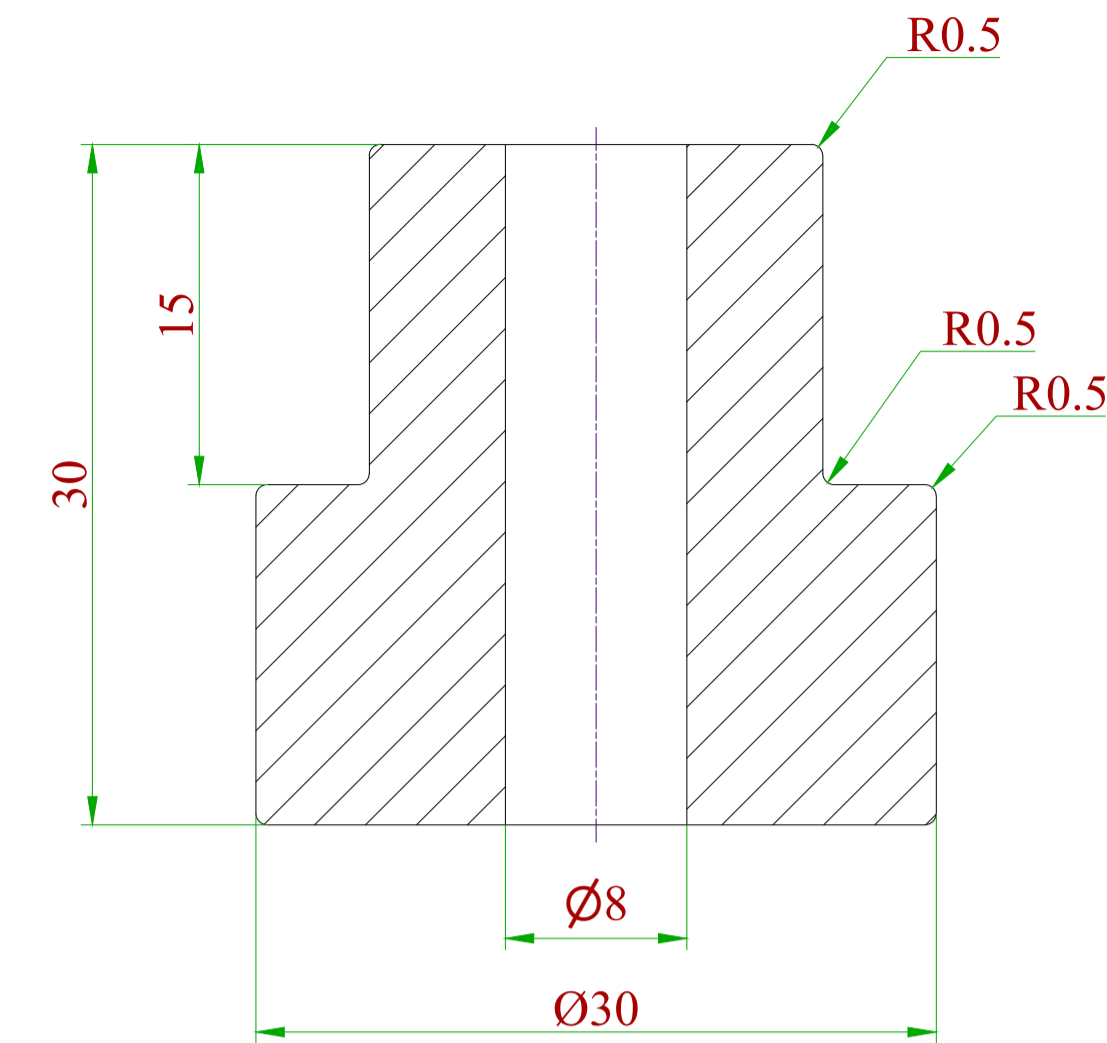

Pos. 11 : Bush View
Scale : (2 : 1)

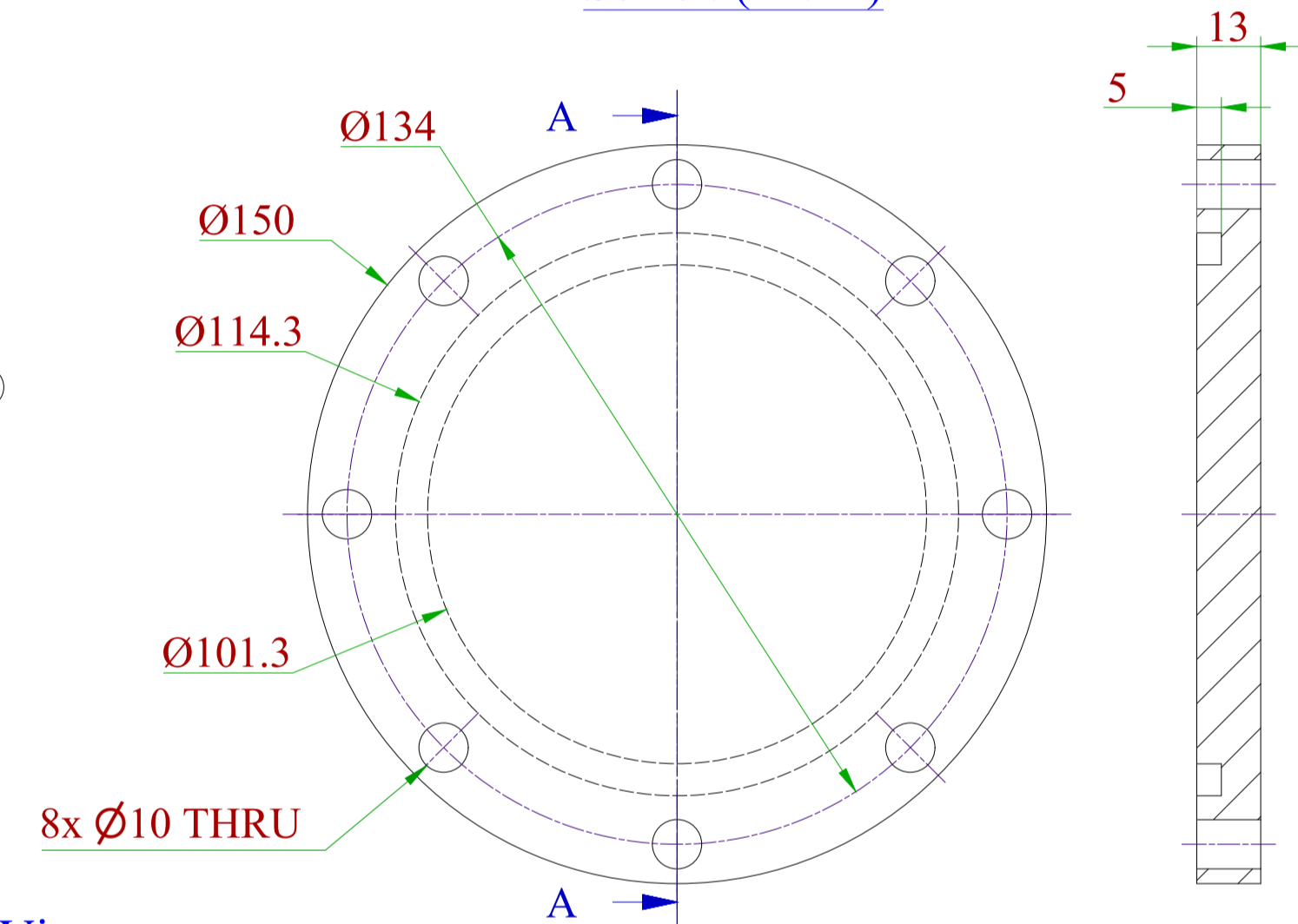

Pos. 02 : Blind Flange View
Scale : (1 : 2)

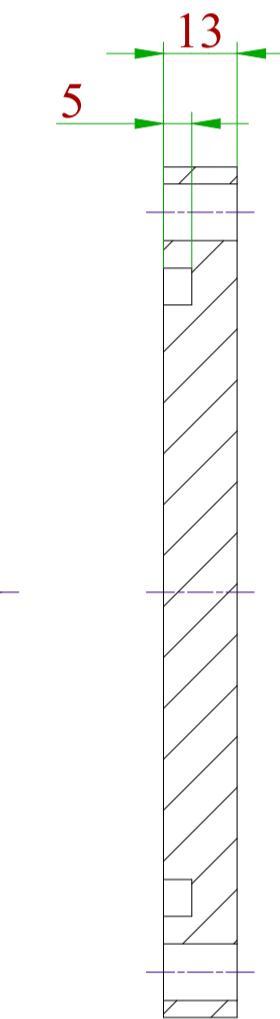

Section A-A
Scale : (1 : 2)

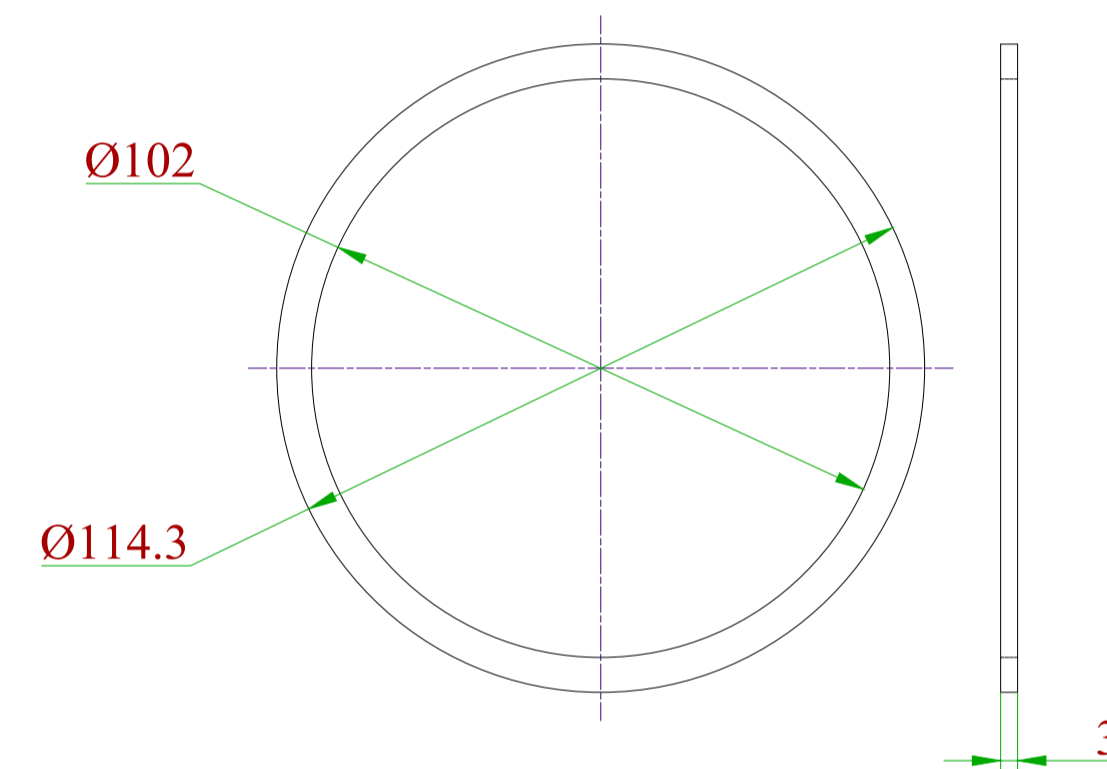

Pos. 03 : Seal Ring View
Scale : (1 : 2)

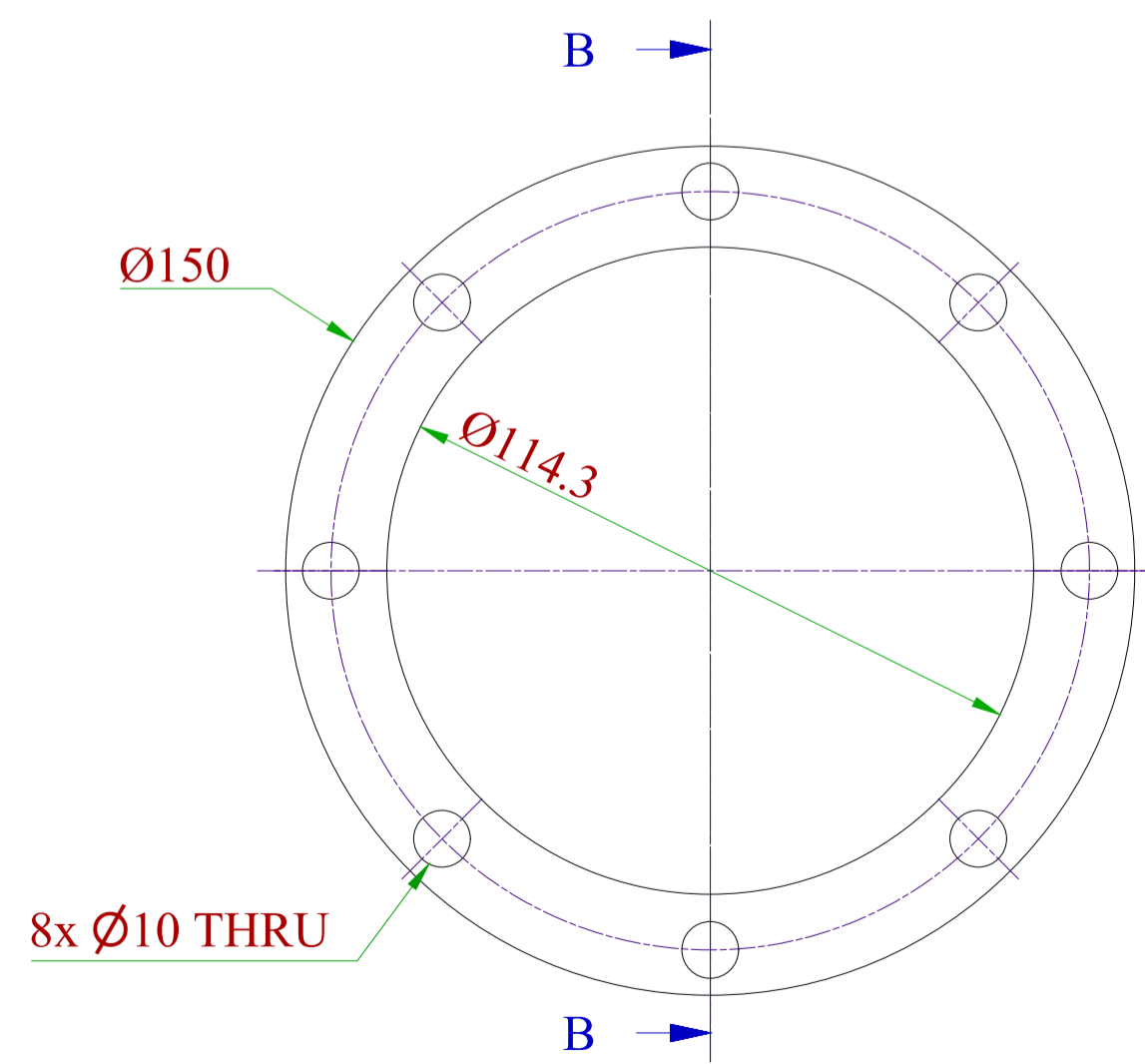

Pos. 16 : End Flange View
Scale : (1 : 2)

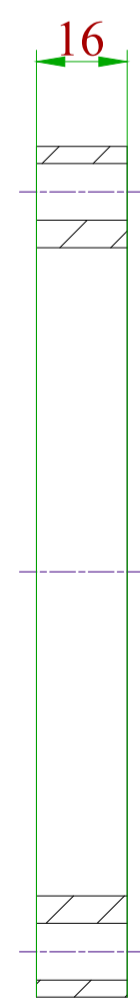

Section B-B
Scale : (1 : 2)

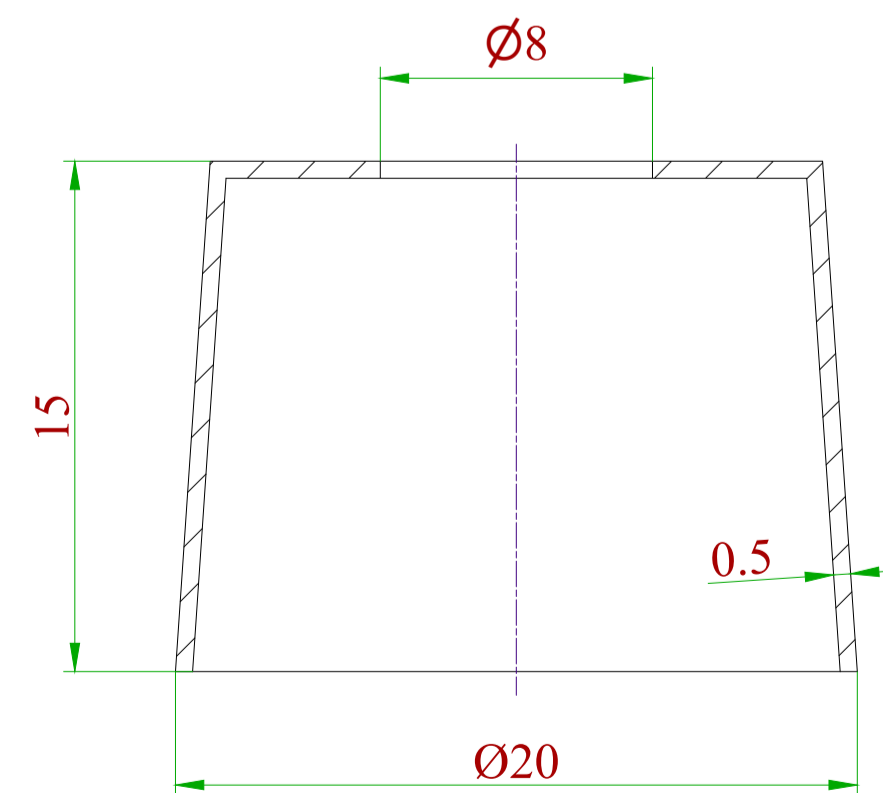

Pos. 09 : Strainer Cap View
Scale : (3 : 1)

Pos.	ITEM	Description	Material	Qty	Unit Weight	Total Weight
14-3	Pipe	Pipe - Sch.40s, ANSI B36.19	S.S.304	1	0.70 kg	0.70 kg
14-2	Spacer	Ø50 X Th.=22	S.S.304	1	1.2 kg	1.2 kg
14-1	Semi Cone	Note.1	S.S.304	1	0.039 kg	0.039 kg

PARTS LIST

CLIENT:	MC	CONTRACTOR:
<small>Persian Gulf Petrochemical Industries Co.</small>	<small>Persian Gulf Petrochemical Industries Co. (PGPIC)</small>	<small>Petropars Ltd.</small>

This document is the property of DPIC. Any unauthorized attempt to reproduce it, in any form, is strictly prohibited.

PROJECT TITLE:
DEHDASHT PETROCHEMICAL INDUSTRY COMPANY
DEHDASHT HIGH DENSITY POLYETHYLENE PROJECT

DRAWING TITLE:
FILTER DRYER DRAWING

DOCUMENT No:	DPIC9812-000-VD-1002-ME-DWG-0025	SC.
Proj. Code	Area No.	VD
Material Code	PO No.	Disc. Code
Doc. Type	Serial No.	Rev.
		4 of 4

PURCHASER'S COMMENT/APPROVAL STATUS		PURCHASER:
1. AP: Approved (Released for Manufacturing)		
2. AM: Approved With Minor Comments (Fabrication may Proceed)		REQUISITION NO.:
3. NF: Approved With Comments (Fabrication not Proceed)		
4. RJ: Rejected		ITEM NO. (TAG NO.):
5. NR: Not be Returned		F-PK6101-2
Date: XX.XX.XX	Signature:	VENDOR DOC. NO.:

REV	DATE	DESCRIPTION	PREP'D	CHK'D	APP'D
00	02-01-2022	ISSUE FOR APPROVAL	F.SARLAK	M.NAZARSHOAR	DR.A.NEJATI