



DEHDASHT PETROCHEMICAL INDUSTRY COMPANY
DEHDASHT HIGH DENSITY POLYETHYLENE PROJECT



Contract No.: DPIC/98-12	DOCUMENT TITLE: Oil Pump Drawing	POI: IFA	Rev.: D0
	DOCUMENT No: DPIC9812-000-VD-1002-ME-DWG-0018	Sheet 1 of 4	

Oil Pump Drawing

PURCHASER'S COMMENT/APPROVAL STATUS

Purchaser: NARGAN

1	AP: Approved (Released for Manufacturing)	
<input checked="" type="checkbox"/>	AN: Approved With Minor Comments (Fabrication may Proceed)	Requisition No.: DPIC98-12-001-000-ME-MR-4150-0001-D1
3	NF: Approved With Comments (Fabrication not Proceed)	
4	RJ: Rejected	Item No. (Tag No.): PK-6101
5	NR: Not be Returned	
Date:	<input type="text" value="03.01.2022"/>	Signature: <input type="text" value="A.AB"/>
		Vendor Doc. No.: DPIC9812-000-VD-1002-ME-DWG-0018



D0	22-Dec-21	IFA	MY	M.M	A.V
REV.	DATE ISSUE	Purpose of Issue	PREPARED	CHECKED	APPROVED



DEHDASHT PETROCHEMICAL INDUSTRY COMPANY
DEHDASHT HIGH DENSITY POLYETHYLENE PROJECT



Contract No.: DPIC/98-12

DOCUMENT TITLE: Oil Pump Drawing

POI: IFA

Rev.: D0

DOCUMENT No: DPIC9812-000-VD-1002-ME-DWG-0018

Sheet 2 of 4

TABULATION OF REVISED PAGES

Page	Rev-D0	Rev-D1	Rev-D2	Rev-D3	Rev-D4
1	x				
2	x				
3	x				
4	x				
5					
6					
7					
8					
9					
10					
11					
12					
13					
14					
15					
16					
17					
18					
19					
20					
21					
22					
23					
24					
25					
26					
27					
28					
29					
30					
31					
32					
33					
34					
35					

Page	Rev-D0	Rev-D1	Rev-D2	Rev-D3	Rev-D4
36					
37					
38					
39					
40					
41					
42					
43					
44					
45					
46					
47					
48					
49					
50					
51					
52					
53					
54					
55					
56					
57					
58					
59					
60					
61					
62					
63					
64					
65					
66					
67					
68					
69					
70					

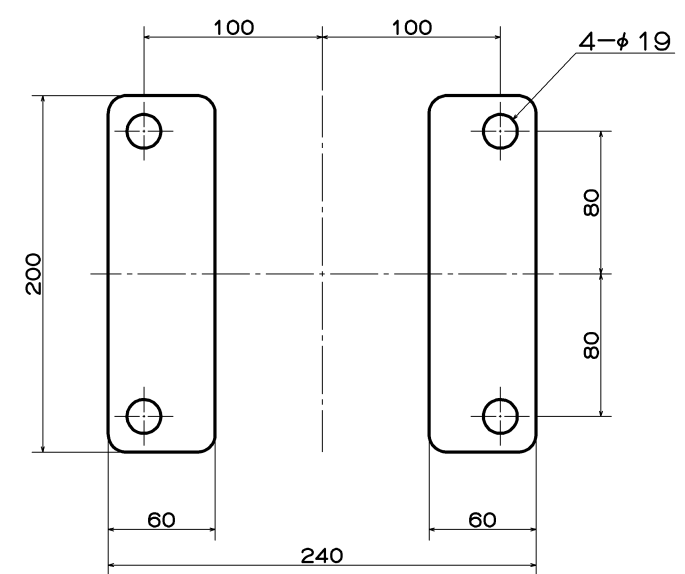
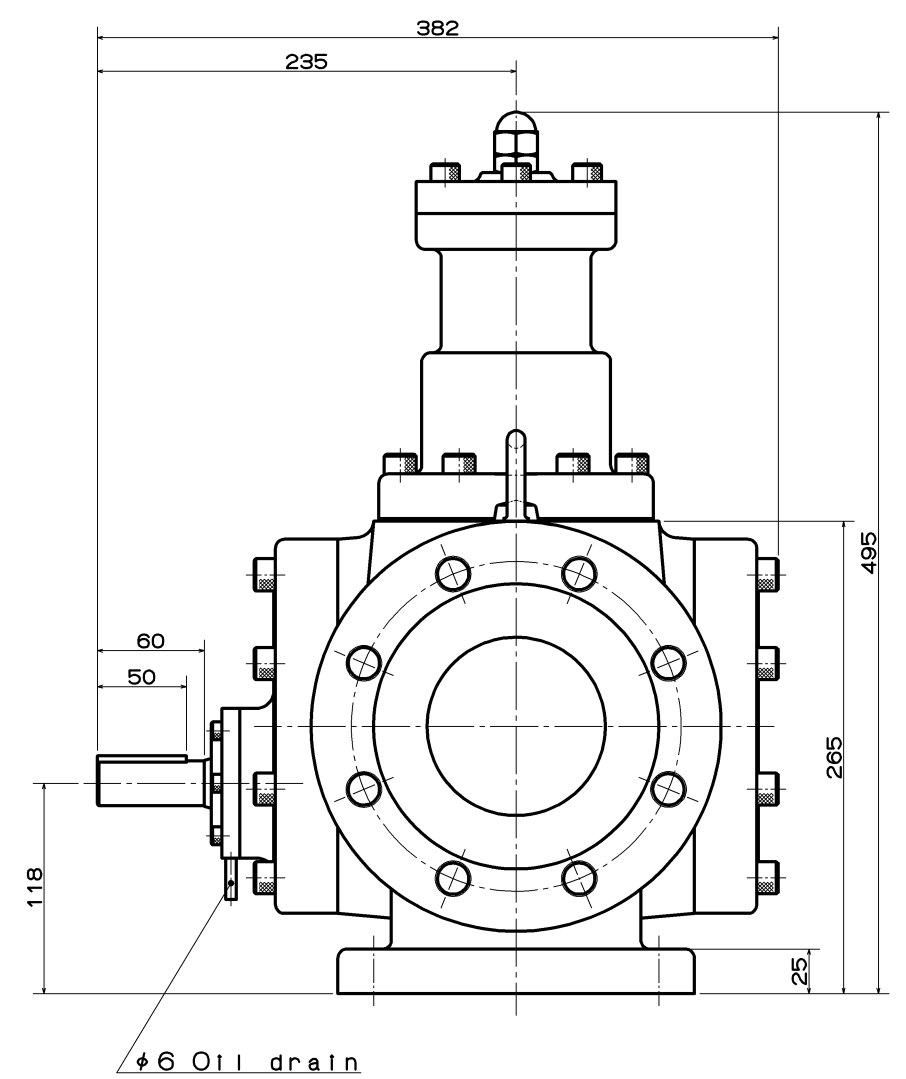
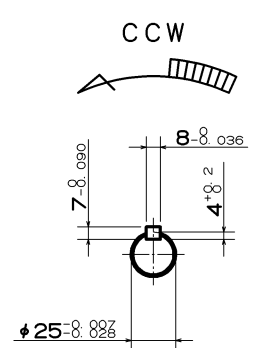
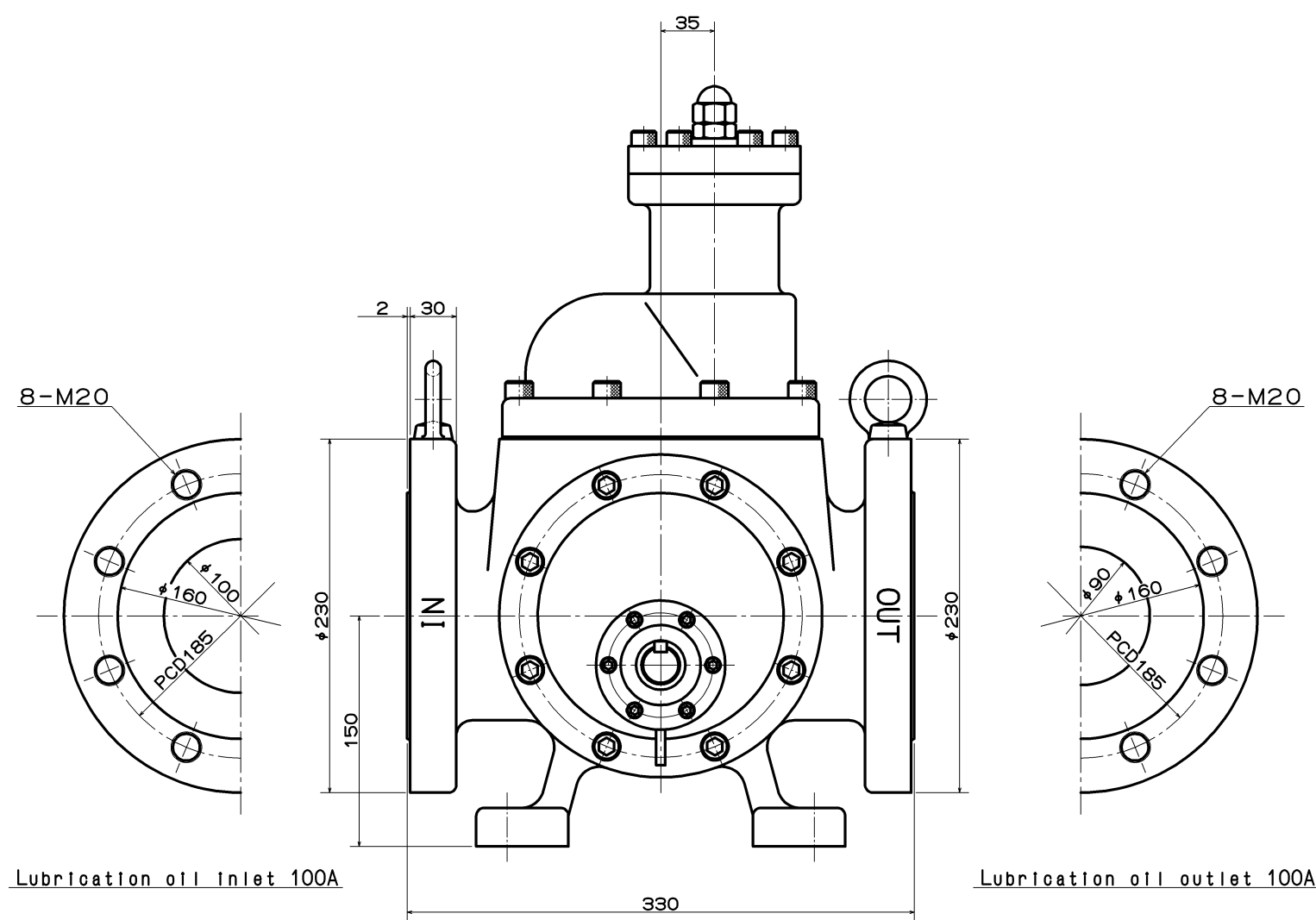

flanges shall be as per ASME design otherwise mating shall be provided by vendor

品番 NO.	部品名 PARTS NAME	材質 MATERIAL	個数 Q.ty	備考 REMARKS
図名 NAME	OUTER DIMENSION MYCOM M80P OIL PUMP		設計 DESIGNED	検図 CHECKED
図番 FIG. NO.	08P80600-01	尺度 SCALE	1/3	承認 APPROVED
日付 DATE	1997. 01. 30			生頭 I. Shiga
MYCOM 株式会社 前川製作所 技術研究所		MAYEKAWA MFG. CO., LTD.		MORIYA FACTORY