



Page 1 of 8

Inspection Date :	10.11.2023	Order status: <input type="checkbox"/> complete <input checked="" type="checkbox"/> partial
File No:	DPIC-EM-RP- 02/2243	Insp. Note. No.: IN-299-1002-0002
Client/project :	DPIC	P/O, M/R No.: DPIC-PO-NEC-299-1002
Vender/sub vendor :	Kasravand Co. / J. HELMKE & Co.	Inspection Location : Helmke Gruppe Sarstedt , Germany
1) inspected Material (in details)		1- کالا/مواد مورد بازرسی (جزئیات)
Two 1340 KW Electrical Motors with type model NDKK450-02-G Two other motors were repacked and the inspector was not allowed to open them. Total: 4 pcs (no item list was provided by the client)		
2) Scope of inspection	<input checked="" type="checkbox"/> Review of document <input type="checkbox"/> Quality control <input type="checkbox"/> Performance test <input checked="" type="checkbox"/> Packing and marking	<input checked="" type="checkbox"/> بررسی مدارک <input type="checkbox"/> بررسی کیفیت <input type="checkbox"/> آزمون کارایی <input checked="" type="checkbox"/> بسته بندی و نشانه گذاری
<input checked="" type="checkbox"/> Visual <input checked="" type="checkbox"/> Dimension test <input type="checkbox"/> sampling & Witness test		2- زمینه بازرسی <input checked="" type="checkbox"/> ظاهری <input checked="" type="checkbox"/> ابعادی <input type="checkbox"/> نمونه گیری و آزمون در حضور
3) Applicable documents		3- منابع و مراجع مورد استفاده بازرسی
<ul style="list-style-type: none"> Main Motor Drawing No. DPIC9812-000-VD-1002-ME-DWG-0014-D0 Inspection & Test Plan (ITP) for Refrigeration Unit (PK-6101) No. DPIC9812-000-VD-1002-ME-ITP-0008 Specification of routine tests on asynchronous machines with squirrel cage rotors Main Motor Data Sheet and Curve No. DPIC9812-000-VD-1002-ME-DS-0042 		
4) Instruments used		4- ابزار و وسایل مورد استفاده در بازرسی
1-Tape Meter		
5) Inspection description		5- شرح کامل بازرسی
According to the received inspection notification No. IN-299-1002-0002, the inspector visited HELMKE warehouse to perform pre-shipment inspection including quantity check, visual and identification check, dimensional control, document review, packing and marking check. The following results were recorded by the inspector: Quantity Check:		

Inspected by:	Checked by:	Approved by:
Mr. Mohammad Mehdi Shafizadeh	R.NIKRAVESH	



Page 2 of 8

Inspection Date :	10.11.2023	Order status: <input type="checkbox"/> complete <input checked="" type="checkbox"/> partial
File No:	DPIC-EM-RP- 02/2243	Insp. Note. No.: IN-299-1002-0002

Two identical Electro motors have been visually inspected at HELMKE Gruppe company's yard. There were four identical motors that **two of them were initially Pre-Packed** with Plastics and Bands and the other two was the purpose of the inspection. So, these two motors with the following series number "11000101138-39" and the following model identification "NDKK450-02-G".

Visual and Identification Check:

At first, the Motors labels and Nameplates including manufacturer's name, description of goods, serial number, operation details, weight, were checked which are compliance with data sheet and curve No. DPIC9812-000-VD-1002-ME-DS-0042. Then the motors body are visually inspected. All the components are seemed new, without scratch, Coating and coloring was in a good condition, The Rotor seems completely new without any significant stains or scratches. All the motors connections were in a good condition.

The routine tests were not performed in presence of the inspector. the vendor declared this step should be performed before the pre-shipment stage.

Dimensional Control:

The Motors dimension checking have been performed for accessible external parts. All the measurements for both motors especially in the rotors part (Motor's front), the whole-body measurements, the height from the ground were controlled as per drawing No. DPIC9812-000-VD-1002-ME-DWG-0014-D0.

Inspected by:	Checked by:	Approved by:
Mr. Mohammad Mehdi Shafizadeh	R.NIKRAVESH	



Inspection Date :	10.11.2023	Order status: <input type="checkbox"/> complete <input checked="" type="checkbox"/> partial
File No:	DPIC-EM-RP- 02/2243	Insp. Note. No.: IN-299-1002-0002

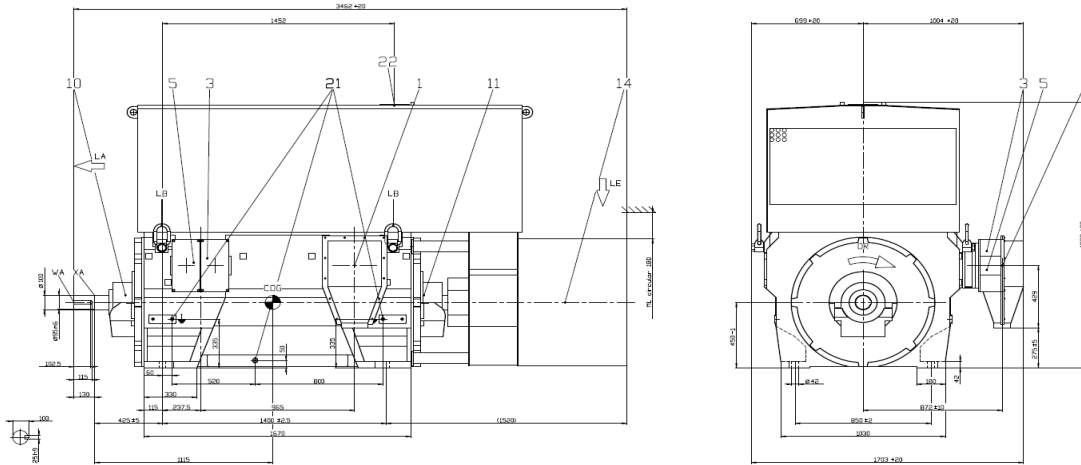

Document Review:

The documents declaration of conformity, specification of routine tests on asynchronous machines with squirrel cage rotors, operating manual, technical data for configuration, test certificates and drawings which were provided by the client, were reviewed by the inspector.

No documents material test certificates, functional test reports and etc were provided to the inspector at the day of the inspection. The inspector asked for the test results and its certification for the motors and the providers said that those documents will be delivered next week.

Packing and Marking Check:

Repacking or packing of the motors have not performed that day. Also, No packing list and shipping marks were prepared yet.

6) Non-Conformances <input checked="" type="checkbox"/> Yes..... <input type="checkbox"/> NO	No documents were provided. The final packing and marking were not prepared yet.	6- عدم تطابق <input checked="" type="checkbox"/> دارد..... <input type="checkbox"/> ندارد
--	---	---

Inspected by: Mr. Mohammad Mehdi Shafizadeh	Checked by: R.NIKRAVESH	Approved by:



Page 4 of 8

Inspection Date :	10.11.2023	Order status: <input type="checkbox"/> complete <input checked="" type="checkbox"/> partial
File No:	DPIC-EM-RP- 02/2243	Insp. Note. No.: IN-299-1002-0002
7) Conclusion <input type="checkbox"/> Accepted <input type="checkbox"/> Rejected <input checked="" type="checkbox"/> NCR.....	7- نتیجه بازرسی <input type="checkbox"/> مورد تایید است <input type="checkbox"/> مردود است <input checked="" type="checkbox"/> دارای عدم تطابق است	
8) Further Activities <input checked="" type="checkbox"/> Yes: Final packing and marking check, Document review, Dimensional check for two remain motors <input type="checkbox"/> NO	8- شرح کار آینده <input checked="" type="checkbox"/> دارد <input type="checkbox"/> ندارد	

9) Remarks	9) توجیهات
No documents were provided. The final packing and marking were not prepared yet.	
10) Attachments/Photos	10) ضمائم /تصاویر
MOM	
Photos	

Inspected by:	Checked by:	Approved by:
Mr. Mohammad Mehdi Shafizadeh	R.NIKRAVESH	



Inspection Date :	10.11.2023	Order status: <input type="checkbox"/> complete <input checked="" type="checkbox"/> partial
File No:	DPIC-EM-RP- 02/2243	Insp. Note. No.: IN-299-1002-0002



Motor's Label



Inspector's Photo



Pre-Packaging Model



Motor's Nameplate

Inspected by: Mr. Mohammad Mehdi Shafizadeh	Checked by: R.NIKRAVESH	Approved by:



Page 6 of 8

Inspection Date :	10.11.2023	Order status: <input type="checkbox"/> complete <input checked="" type="checkbox"/> partial
File No:	DPIC-EM-RP- 02/2243	Insp. Note. No.: IN-299-1002-0002



Motor Visual Inspection



Motor's visual Inspection

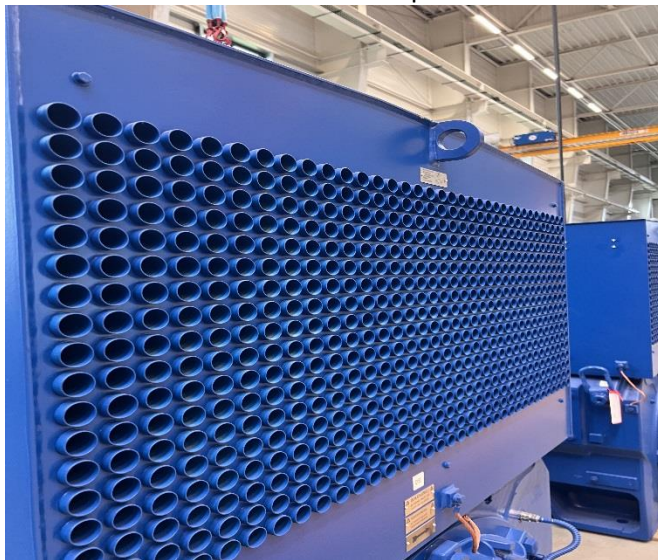

Motors Component's Inspection



Motors Dimension Check

Inspected by:	Checked by:	Approved by:
Mr. Mohammad Mehdi Shafizadeh	R.NIKRAVESH	



Inspection Date :	10.11.2023	Order status: <input type="checkbox"/> complete <input checked="" type="checkbox"/> partial
File No:	DPIC-EM-RP- 02/2243	Insp. Note. No.: IN-299-1002-0002



Motor's Dimension Check



Motors Dimension Check

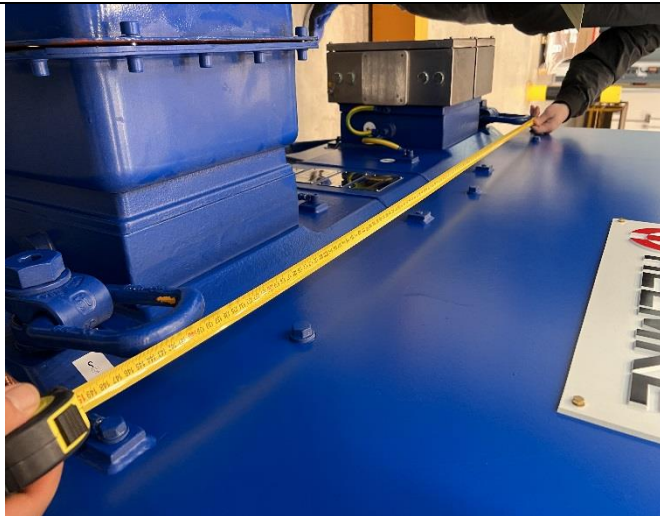

Motor's Dimensions Check



Motor's Dimension Check

Inspected by:	Checked by:	Approved by:
Mr. Mohammad Mehdi Shafizadeh	R.NIKRAVESH	



Page 8 of 8

Inspection Date :	10.11.2023	Order status: <input type="checkbox"/> complete <input checked="" type="checkbox"/> partial
File No:	DPIC-EM-RP- 02/2243	Insp. Note. No.: IN-299-1002-0002



Other Motors Components

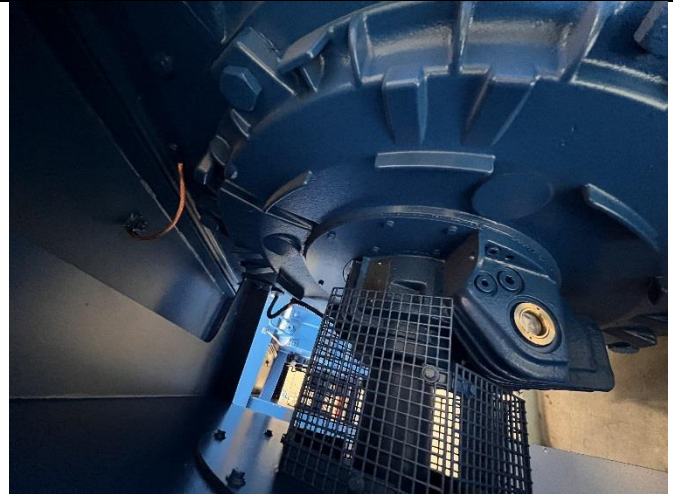

Other Motor's Component

Inspected by:	Checked by:	Approved by:
Mr. Mohammad Mehdi Shafizadeh	R.NIKRAVESH	

Inspection M.O.M

Client: -

Vendor / Manufacturer: J. HELMKE & Co.

Equipment/Product: MAIN MOTOR

Date of inspection: 10.11.2023

Inspection location: Ludwig-Erhard-Ring 7-9-31157 Sarstedt-Deutschland- Germany

Present Persons

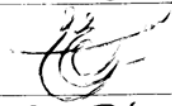
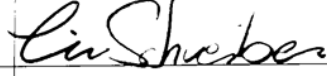
Name	Company	Title	Signature
Mr. Shafizadeh	FP	Inspector	
Mr. Schreiber	HELMKE	Project Manager	

Row	Description of Inspection
1	<p>According to notification No. IN-299-1002-0002, the following steps was performed and results will be reported:</p> <ol style="list-style-type: none">1. QTY checking2. Dimensional checking3. Visual checking4. Marking and nameplate checking5. Document review
2	<p>The routine tests were not performed in presence of the inspector. the vendor declared this step should be performed before the pre-shipment stage.</p>
3	<p>Two main motors were prepacked and the inspector was not allowed to open them. The packing representative was not there at the day of the inspection. Also, the final packing and marking were not prepared yet.</p>
4	<p>the documents test reports and packing procedure will be sent on next week by the vendor.</p>