







 Gachsaran Polymer Industries Company	Gachsaran Polymer Industries Company HDPE Plant		
	General Arrangement Drawing (2D) (*Tie-In Points , Skid Dimensions & Orientation, Including Instrument, Junction Box and Local Panel Location Layout & Instrument Cable routing.) for Refrigerator Package	 	
PO No.: GPIC-PT-MA-PO-000-3029	Document Number: VD-GPIC-MA-3029-3029-0062	Rev. 00	Page 1 of 11

General Arrangement Drawing (2D) (*Tie-In Points , Skid Dimensions & Orientation, Including Instrument, Junction Box and Local Panel Location Layout & Instrument Cable routing.) for Refrigerator Package

Code1	<input type="checkbox"/> No Comment/ Approved (Applicable Only for "FOR REVIEW" and "For Approval" Documents) No comment and the document are released for Manufacturing.
Code2	<input type="checkbox"/> No Comment/ Approved with Note(s) Vendor/Sub-Contractor shall correct, revise and resubmit the document. The document is released for Manufacturing if changes incorporated.
Code3	<input checked="" type="checkbox"/> Commented Vendor/Sub-Contractor shall correct, revise and resubmit the document by the date specified. The document shall be revised under the Status of "R: Revised Issue". All corrected documents shall be resubmitted before starting the Manufacturing Process.
Code 4	<input type="checkbox"/> Not Accepted (Rejected) Vendor/Sub-Contractor shall re-work / re-design / re-specify the contents of the document according to the comments / reasons for rejection. All corrected documents shall be resubmitted before starting the manufacturing. Vendor/Sub-Contractor shall not proceed with subsequent works of Material Supply or Manufacturing until receiving Code1/Code2 or No Code from PURCHASER. Vendor/Sub-Contractor shall resubmit the document with the same revision within 6 working days after receiving comments.
No code	<input type="checkbox"/> No Code (Applicable Only for "For Information" Documents and "As Built DWGs") Document has been submitted for PURCHASER's Information (FI). Consistency, completeness and correctness of document content is in Vendor/Sub-Contractor's responsibility.
Above checking results by EIED shall in no way relieve Vendor of any liability, obligation and responsibility out of the purchase order and the mutual agreement in writing.	
 Energy Industries Engineering & Design co.	Date: Jul.20, 2025 Dept.: MA Signature: F.Hamooni

00	28-Jun-25	IFR	A.M	A.M	F.T
Rev.	DATE	PURPOSE OF ISSUE	PREPARED	CHECKED	APPROVED

  Gachsaran Polymer Industries Company PIDMCO	Gachsaran Polymer Industries Company HDPE Plant		
	General Arrangement Drawing (2D) (*Tie-In Points , Skid Dimensions & Orientation, Including Instrument, Junction Box and Local Panel Location Layout & Instrument Cable routing.) for Refrigerator Package	 	
PO No.: GPIC-PT-MA-PO-000-3029	Document Number: VD-GPIC-MA-3029-3029-0062	Rev. 00	Page 2 of 11

Revision Index

Page	Rev. 00	Rev. 01	Rev. 02	Rev. 03	Rev. 04
1	X				
2	X				
3	X				
4	X				
5	X				
6	X				
7	X				
8	X				
9	X				
10	X				
11	X				

Page	Rev00	Rev. 01	Rev. 02	Rev. 03	Rev. 04

PI-01:

1- Displacement and allowable loads at tie-in points shall be specified by vendor. Table of Allowable nozzle loads shall be add for tie-in points.

2- Isometric of piping inside package including supports type(rest, Guide , Stop) and position, shall be provided by vendor.

- Furthermore, fixed(anchor) supports shall be considered at tie-ins with EIED in order to separating scope of work.

3- Stress Analysis Report including Caesar II native files for critical pipes inside package shall be provided by vendor.

4- Expansion joints data sheet (including type, spring rate and etc.) shall be provided by vendor. (if required)

22					
23					
24					
25					

EL02: Local Panel and junction boxes shall be numbered and displayed in a table with tags.

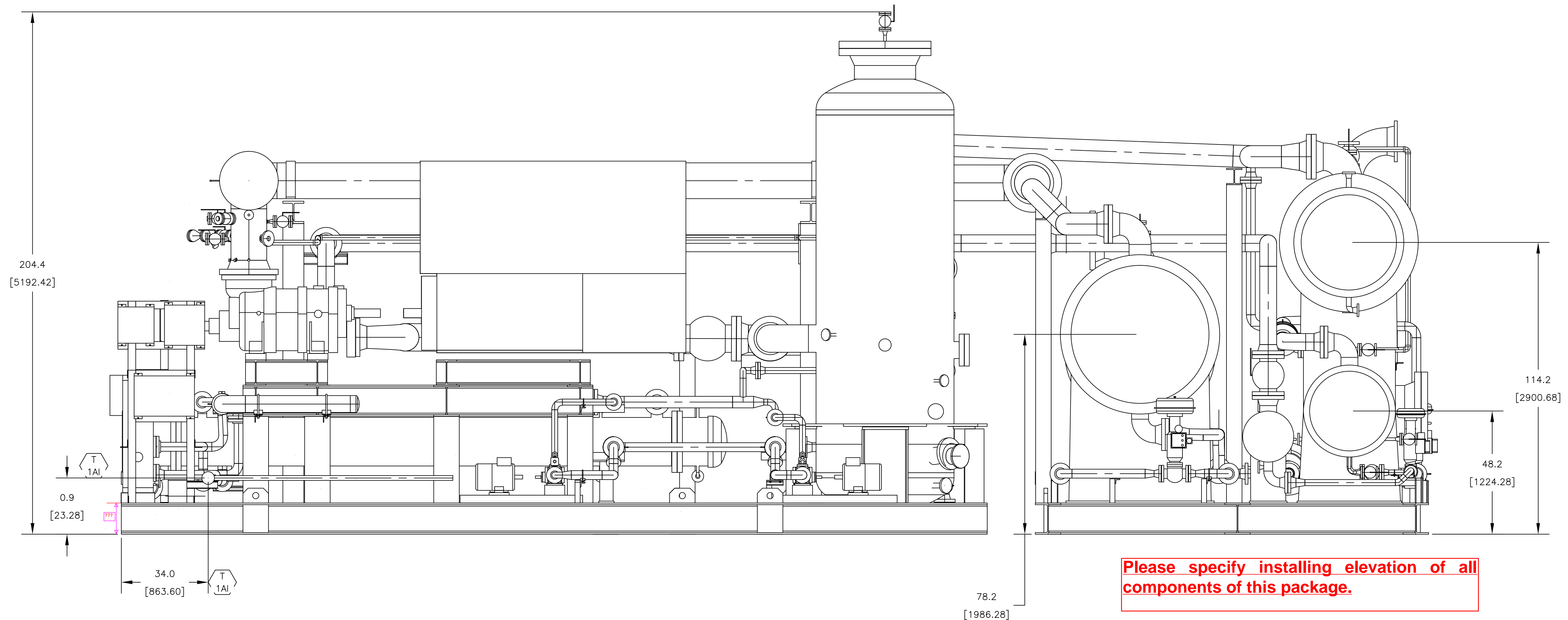

FRONT VIEW

Code1	<input type="checkbox"/> No Comment/ Approved (Applicable Only for "FOR REVIEW" and "For Approval" Documents) No comment and the document are released for Manufacturing				
Code2	<input type="checkbox"/> No Comment / Approved with Note(s) Vendor/Sub-Contractor shall correct, revise and resubmit the document. The document is released for Manufacturing if changes incorporated.				
Code3	<input type="checkbox"/> Commented Vendor/Sub-Contractor shall correct, revise and resubmit the document by the date specified. The document shall be revised under the Status of "R: Revised Issue". All corrected documents shall be resubmitted before starting the Manufacturing Process				
Code4	<input type="checkbox"/> Not Accepted (Rejected) Vendor/Sub-Contractor shall re-work/re-design/re-specify the contents of the document according to the comments/reasons for rejection. All corrected documents shall be resubmitted before starting the manufacturing. Vendor/Sub-Contractor shall not proceed with subsequent work of Material Supply or Manufacturing until receiving Code1/Code2 or No Code from PURCHASER. Vendor/Sub-Contractor shall resubmit the document with the same revision within 6 working days after receiving comments				
No Code	<input type="checkbox"/> No Code (Only for "For Informator" Documents and "As Built DWG") Document has been submitted for PURCHASER's Information (I). Consistency, completeness and correctness of document content is in Vendor/Sub-Contractor's responsibility. The above checking result by EIED shall in no way relieve Vendor of any liability, obligation and responsibility out of the purchase order and the mutual agreement in writing				
DATE : DEPT : Signature :					
CV	PI	EL	IN	ME	MA
ST	BU	PR	SA	HV	TL

00	28-06-2025	IFR	FA	IM	OG
REV.	DATE (DD.MM.YY)	Purpose of Issue	Prepared	Checked	Approved
		Gachsan Polymer Industries Company HDPE Plant			
PO No.: xxxxxx		CONTRACT NO.: GPI-CON-99-008			
DRAWING TITLE: General Arrangement Drawing (2D) (*Tie-In Points, Skid Dimensions & Orientation, Including Instrument, Junction Box and Local Panel Location Layout & Instrument Cable routing.) for Refrigerator Package					
DRAWING NO.	VD-GPIC-MA-3029- 0062	REV.	SHEET NO.	SIZE	
			4 of 11	A1	

CONNECTION LIST			
NO.	LOCATION	DESCRIPTION	SIZE
T-1AI	COMPRESSOR SKID-A	INSTRUMENT AIR SUPPLY	1"-150 ANSI RF
T-2AI	COMPRESSOR SKID-B	INSTRUMENT AIR SUPPLY	1"-150 ANSI RF
T-4AI	VESSEL SKID	INSTRUMENT AIR SUPPLY	1"-150 ANSI RF
T-3CWS	COMPRESSOR SKID-A	OIL COOLER COOLING WATER SUPPLY	3"-300 ANSI RF
T-3CWR	COMPRESSOR SKID-A	OIL COOLER COOLING WATER RETURN	3"-300 ANSI RF
T-4CWS	VESSEL SKID	OIL COOLER COOLING WATER SUPPLY	10"-300 ANSI RF
T-4CWR	VESSEL SKID	OIL COOLER COOLING WATER RETURN	10"-300 ANSI RF
T-41	VESSEL SKID	FILTER/DRYER INLET	2"-300 ANSI RF
T-51	VESSEL SKID	CHILLER PROCESS INLET	16"-300 ANSI RF
T-52	VESSEL SKID	CHILLER PROCESS OUTLET	16"-300 ANSI RF
S-31	COMPRESSOR SKID-A	OIL SEPARATOR PRESSURE SAFETY	4"-300 ANSI RF
S-41	VESSEL SKID	CONDENSER PRESSURE SAFETY	3"-300 ANSI RF
S-42	VESSEL SKID	RECEIVER PRESSURE SAFETY	4"-300 ANSI RF
S-43	VESSEL SKID	ECONOMIZER PRESSURE SAFETY-SHELL	1-1/2"-300 ANSI RF
S-44	VESSEL SKID	ECONOMIZER PRESSURE SAFETY-TUBE	1"-300 ANSI RF
S-51	VESSEL SKID	CHILLER PRESSURE SAFETY	4"-300 ANSI RF

Gasket contact surface finish for raised or flat faces Flanges, Blind Flanges, Spades, and Spectacle Blinds, shall be finished in accordance with ASME B16.5, concentric or spiral serrated (125-250 μin. AARH) and for RJ flanges as per 63 μin. AARH.

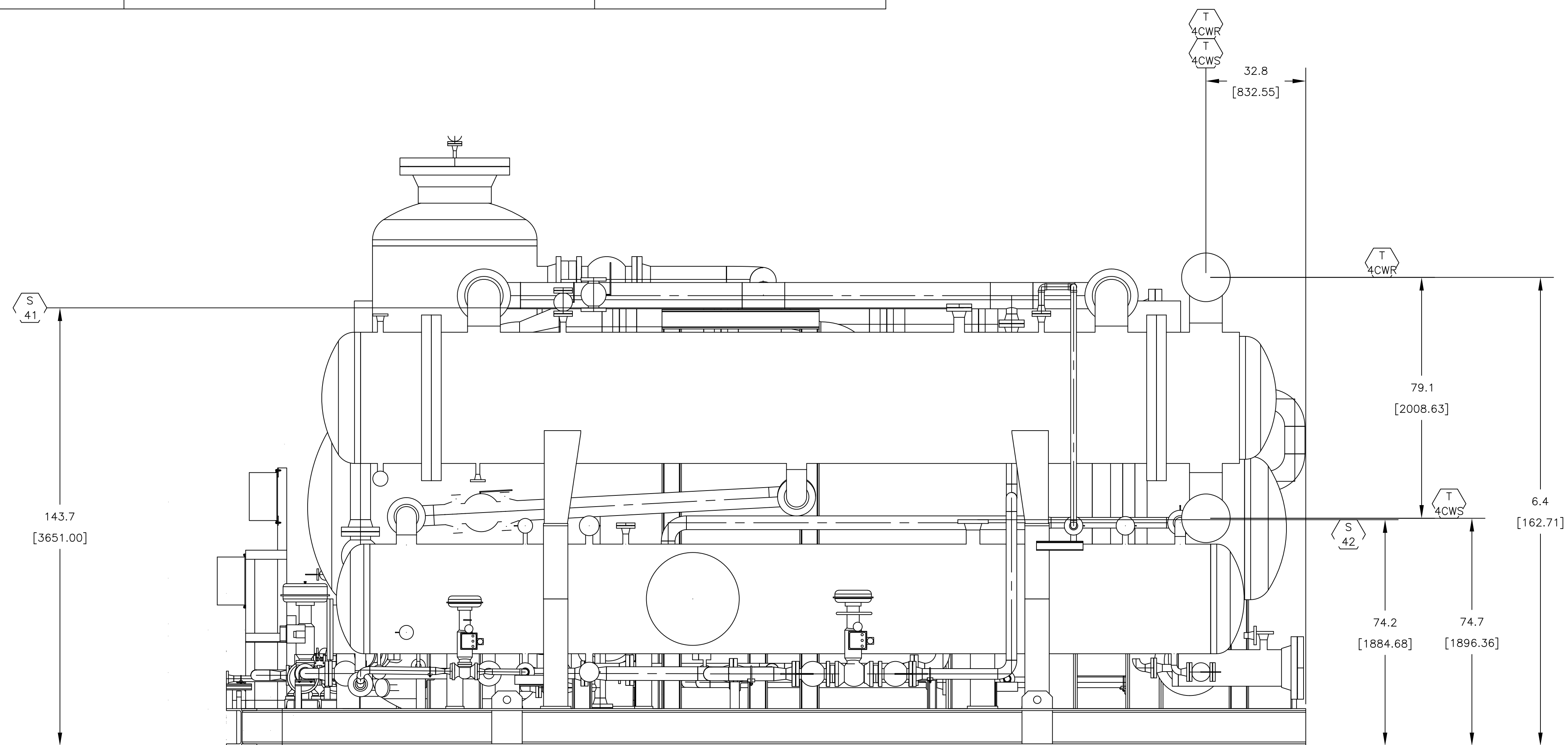

RIGHT VIEW

Code1	<input type="checkbox"/> No Comment/ Approved (Applicable Only for "FOR REVIEW" and "For Approval" Documents) No comment and the document are released for Manufacturing				
Code2	<input type="checkbox"/> No Comment / Approved with Note(s) Vendor/Sub-Contractor shall correct, revise and resubmit the document. The document is released for Manufacturing if changes incorporated.				
Code3	<input type="checkbox"/> Commented Vendor/Sub-Contractor shall correct, revise and resubmit the document by the date specified. The document shall be revised under the Status of "R: Revised Issue". All corrected documents shall be resubmitted before starting the Manufacturing Process				
Code4	<input type="checkbox"/> Not Accepted (Rejected) Vendor/Sub-Contractor shall re-work/re-design/re-specify the contents of the document according to the comments/reasons for rejection. All corrected documents shall be resubmitted before starting the manufacturing. Vendor Sub-Contractor shall not proceed with subsequent work of Material Supply or Manufacturing until receiving Code1/Code2 or No Code from PURCHASER. Vendor/Sub-Contractor shall resubmit the document with the same revision within 6 working days after receiving comments				
No Code	<input type="checkbox"/> No Code (Only for "For Information" Documents and "As Built DWGs") Document has been submitted for PURCHASER'S information (I). Consistency, completeness and correctness of document content is in Vendor/Sub-Contractor's responsibility. The above checking result by EIED shall in no way relieve Vendor of any liability, obligation and responsibility out of the purchase order and the mutual agreement in writing				
DATE : DEPT : Signature :					
CV	PI	EL	IN	ME	MA
ST	BU	FR	SA	HV	TL

00	28-06-2025	IFR	FA	IM	OG
REV.	DATE (DD.MM.YY)	Purpose of Issue	Prepared	Checked	Approved
		Gachsaran Plymer Industries Company HDPE Plant			
CONTRACT NO.: GPI-CON-99-008		SCALE: 1:1			
DRAWING TITLE: General Arrangement Drawing (2D) (Tie-In Points, Skid Dimensions & Orientation, Including Instrument, Junction Box and Local Panel Location Layout & Instrument Cable routing.) for Refrigerator Package					
DRAWING NO.	VD-GPIC-MA-3029- 0062	REV.	SHEET NO.	SIZE	
			5 of 11	A1	

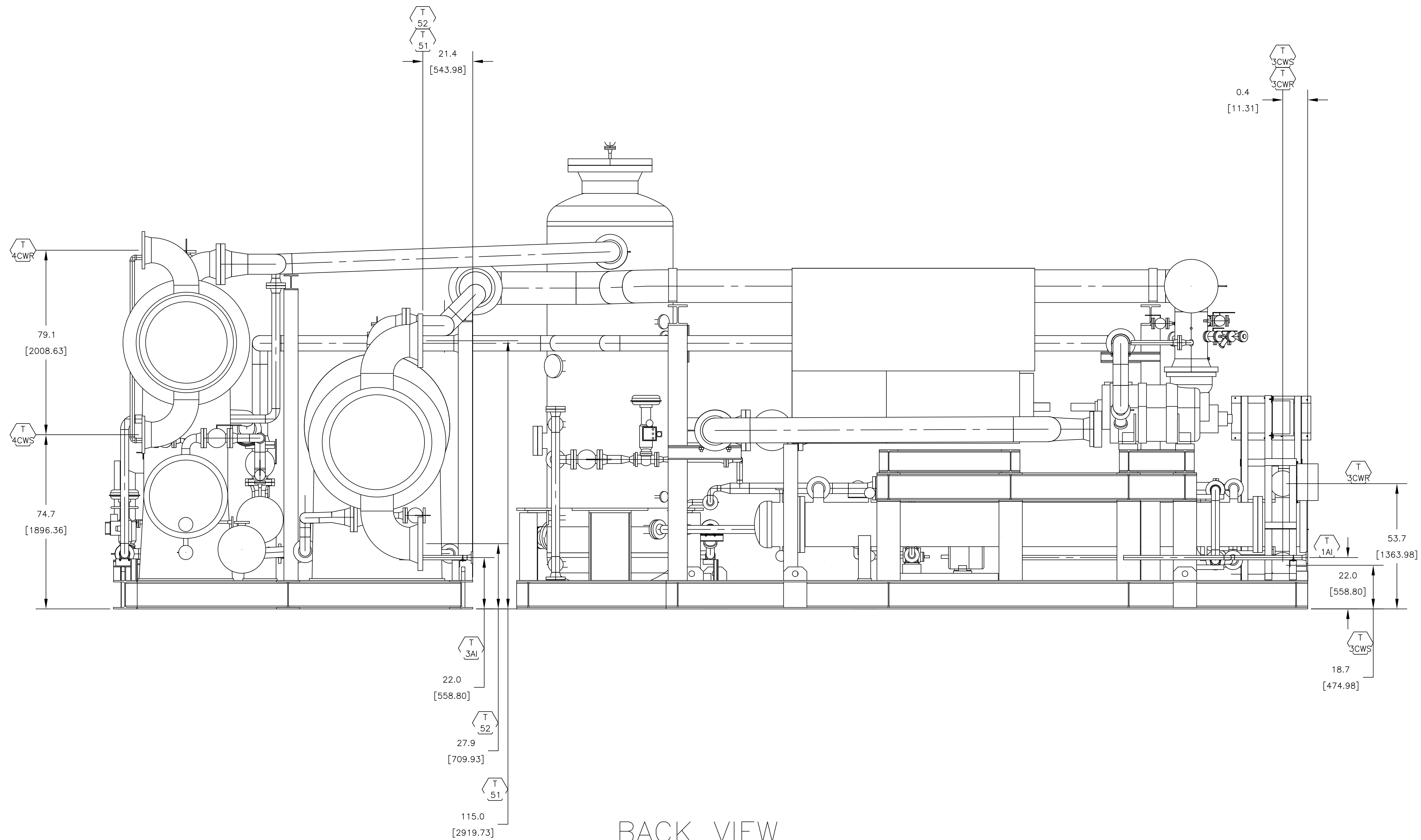

BACK VIEW

Code1	<input type="checkbox"/> No Comment / Approved (Applicable Only for "FOR REVIEW" and "For Approval" Documents) No comment and the document are released for Manufacturing				
Code2	<input type="checkbox"/> No Comment / Approved with Note(s) Vendor/Sub-Contractor shall correct, revise and resubmit the document. The document is released for Manufacturing if changes incorporated.				
Code3	<input type="checkbox"/> Commented Vendor/Sub-Contractor shall correct, revise and resubmit the document by the date specified. The document shall be revised under the Status of "R: Revised Issue". All corrected documents shall be resubmitted before starting the Manufacturing Process				
Code4	<input type="checkbox"/> Not Accepted (Rejected) Vendor/Sub-Contractor shall re-work/re-design/re-specify the contents of the document according to the comments/reasons for rejection. All corrected documents shall be resubmitted before starting the manufacturing. Vendor Sub-Contractor shall not proceed with subsequent work of Material Supply or Manufacturing until receiving Code1/Code2 or No Code from PURCHASER. Vendor/Sub-Contractor shall resubmit the document with the same revision within 6 working days after receiving comments				
No Code	<input type="checkbox"/> No Code (Only for "For Information" Documents and "As Built DWGs") Document has been submitted for PURCHASER'S information (I). Consistency, completeness and correctness of document content is in Vendor/Sub-Contractor's responsibility. The above checking result by EIED shall in no way relieve Vendor of any liability, obligation and responsibility out of the purchase order and the mutual agreement in writing				
<p>DATE : _____</p> <p>DEPT: _____</p> <p>Signature : _____</p>					
CV	PI	EL	IN	ME	MA
ST	BU	FR	SA	HV	TL



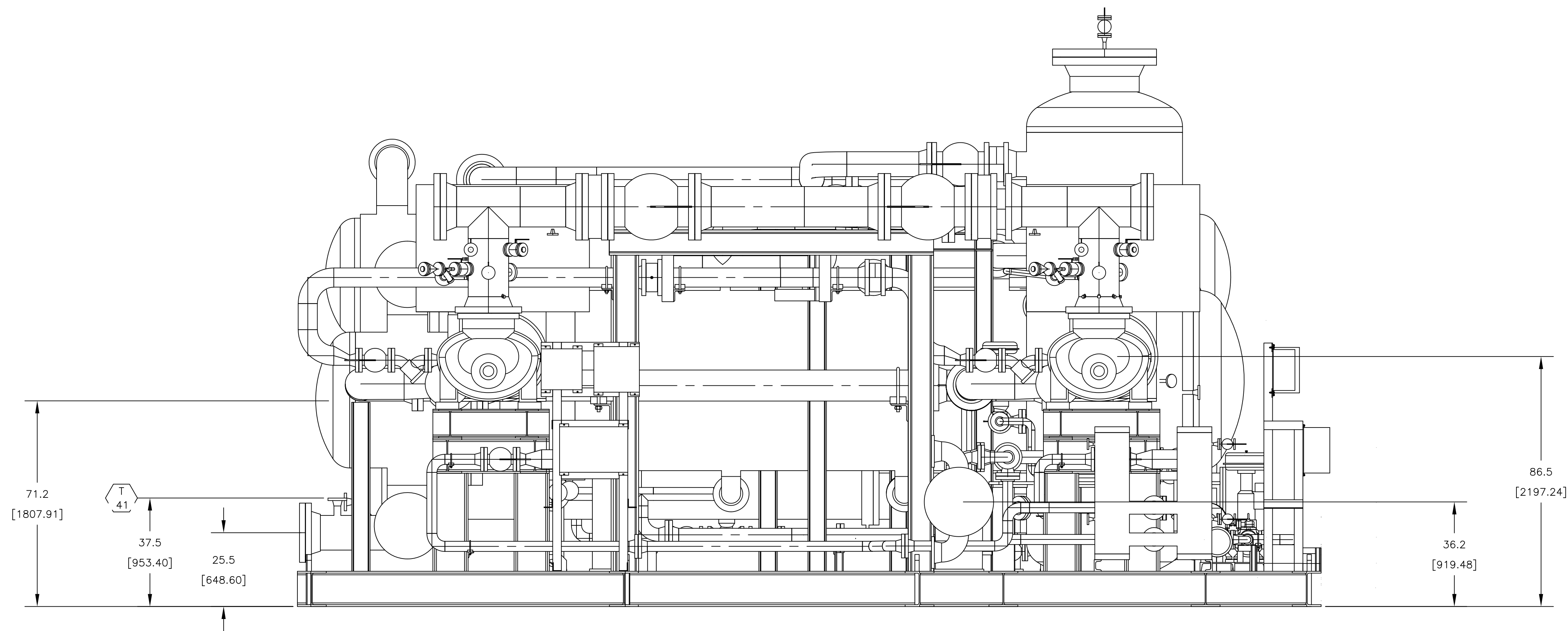

00	28-06-2025	IFR	FA	IM	OG
REV.	DATE (DD.MM.YY)	Purpose of Issue	Prepared	Checked	Approved
		Gachsaran Polymer Industries Company HDPE Plant			
PO No.: xxxxx		CONTRACT NO.: GPI-CON-99-008		SCALE: 1:1	
DRAWING TITLE: General Arrangement Drawing (2D) ("Tie-In Points, Skid Dimensions & Orientation, Including Instrument, Junction Box and Local Panel Location Layout & Instrument Cable routing.) for Refrigerator Package					
DRAWING NO.	VD-GPIC-MA-3029- 0062	REV.	SHEET NO.	SIZE	
			6 of 11	A1	



LEFT VIEW

Code1	<input type="checkbox"/> No Comment/ Approved (Applicable Only for "FOR REVIEW" and "For Approval" Documents) No comment and the document are released for Manufacturing				
Code2	<input type="checkbox"/> No Comment / Approved with Note(s) Vendor/Sub-Contractor shall correct, revise and resubmit the document. The document is released for Manufacturing if changes incorporated.				
Code3	<input type="checkbox"/> Commented Vendor/Sub-Contractor shall correct, revise and resubmit the document by the date specified. The document shall be revised under the Status of "R: Revised Issue". All corrected documents shall be resubmitted before starting the Manufacturing Process				
Code4	<input type="checkbox"/> Not Accepted (Rejected) Vendor/Sub-Contractor shall re-work/re-design/re-specify the contents of the document according to the comments/reasons for rejection. All corrected documents shall be resubmitted before starting the manufacturing. Vendor Sub-Contractor shall not proceed with subsequent work of Material Supply or Manufacturing until receiving Code1/Code2 or No Code from PURCHASER. Vendor/Sub-Contractor shall resubmit the document with the same revision within 6 working days after receiving comments				
No Code	<input type="checkbox"/> No Code (Only for "For Information" Documents and "As Built DWGs") Document has been submitted for PURCHASER'S information (I). Consistency, completeness and correctness of document content is in Vendor/Sub-Contractor's responsibility. The above checking result by EIED shall in no way relieve Vendor of any liability, obligation and responsibility out of the purchase order and the mutual agreement in writing				
 DATE : DEPT : Signature :					
CV	PI	EL	IN	ME	MA
ST	BU	PR	SA	HV	TL

00	28-06-2025	IFR	FA	IM	OG
REV.	DATE (DD.MM.YY)	Purpose of Issue	Prepared	Checked	Approved

		Gachasan Plyomer Industries Company HDPE Plant	
		CONTRACT NO.: GPI-CON-99-008	
PO No.: xxxxx		SCALE: 1:1	

DRAWING TITLE:
General Arrangement Drawing (2D) (*Tie-In Points , Skid Dimensions & Orientation, Including Instrument, Junction Box and Local Panel Location Layout & Instrument Cable routing.) for Refrigerator Package

DRAWING NO.	VD-GPIC-MA-3029- 0062	REV.	SHEET NO.	SIZE
			7 of 11	A1

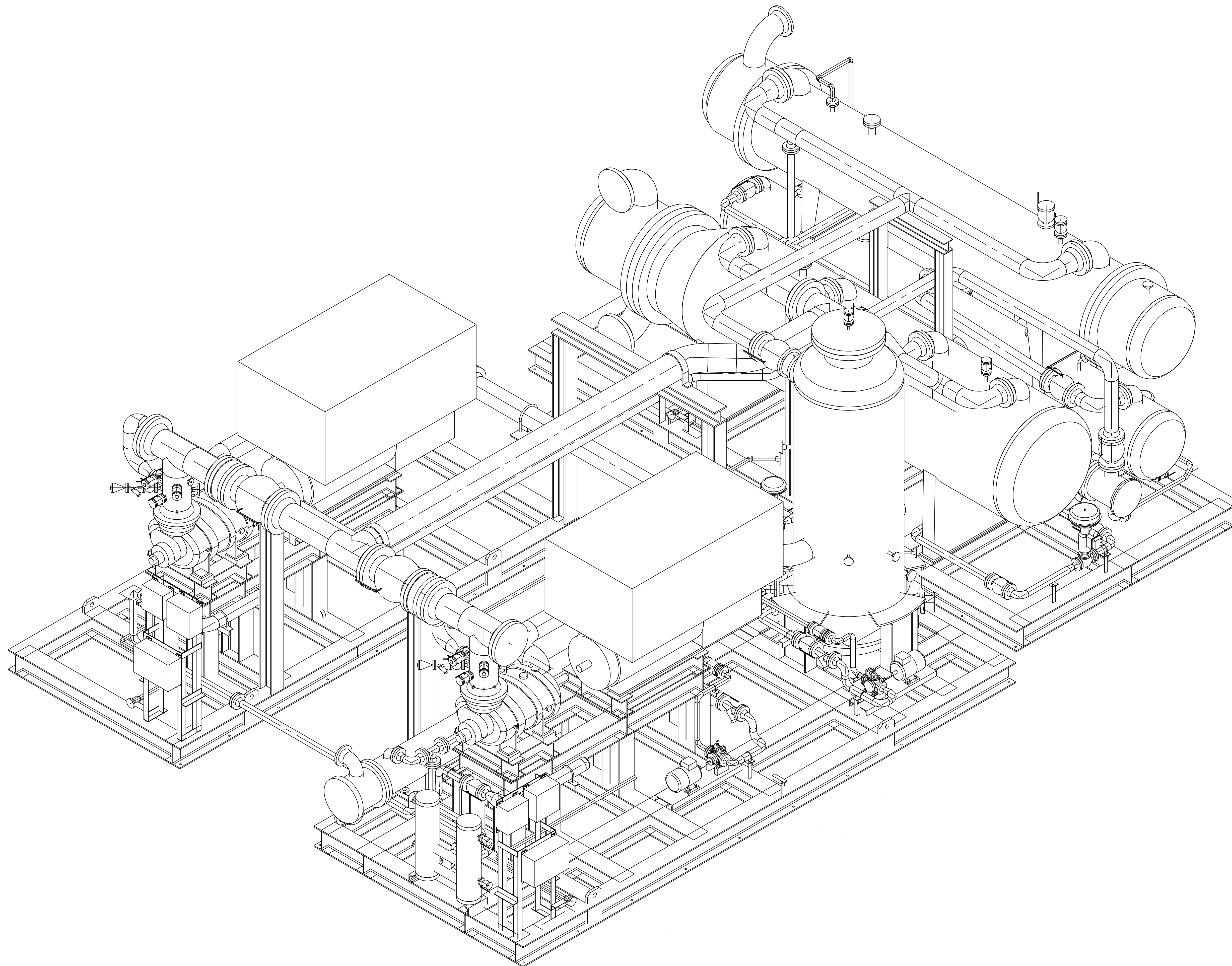

Code1 No Comment/ Approved
(Applicable Only for "FOR REVIEW" and "For Approval" Documents) No comment and the document are released for Manufacturing

Code2 No Comment / Approved with Note(s)
Vendor/Sub-Contractor shall correct, revise and resubmit the document. The document is released for Manufacturing if changes incorporated.

Code3 Commented
Vendor/Sub-Contractor shall correct, revise and resubmit the document by the date specified. The document shall be revised under the Status of "R: Revised Issue". All corrected documents shall be resubmitted before starting the Manufacturing Process

Code4 Not Accepted (Rejected)
Vendor/Sub-Contractor shall re-work/re-design/re-specify the contents of the document according to the comments/reasons for rejection. All corrected documents shall be resubmitted before starting the manufacturing. Vendor/Sub-Contractor shall not proceed with subsequent work of Material Supply or Manufacturing until receiving Code1/Code2 or No Code from PURCHASER. Vendor/Sub-Contractor shall resubmit the document with the same revision within 6 working days after receiving comments





No Code No Code
(Only for "For Information" Documents and "As Built DWG") Document has been submitted for PURCHASER'S information (I). Consistency, completeness and correctness of document content is in Vendor/Sub-Contractor's responsibility.

The above checking result by EIED shall in no way relieve Vendor of any liability, obligation and responsibility out of the purchase order and the mutual agreement in writing

EIED

DATE :
DEPT :
Signature :

CV	PI	EL	IN	ME	MA
ST	BU	PR	SA	HV	TL

00	28-06-2025	IFR	FA	IM	OG
REV.	DATE (dd.MM.Yy)	Purpose of Issue	Prepared	Checked	Approved
 		Gachasan Polymer Industries Company HDPE Plant		 	
CONTRACT NO.: GPI-CON-99-008			SCALE: 1:1		
DRAWING TITLE: General Arrangement Drawing (2D) (*Tie-In Points , Skid Dimensions & Orientation, Including Instrument, Junction Box and Local Panel Location Layout & Instrument Cable routing.) for Refrigerator Package					
DRAWING NO.	VD-GPIC-MA-3029- 0062	REV.	SHEET NO.	SIZE	
			8 of 11	A1	

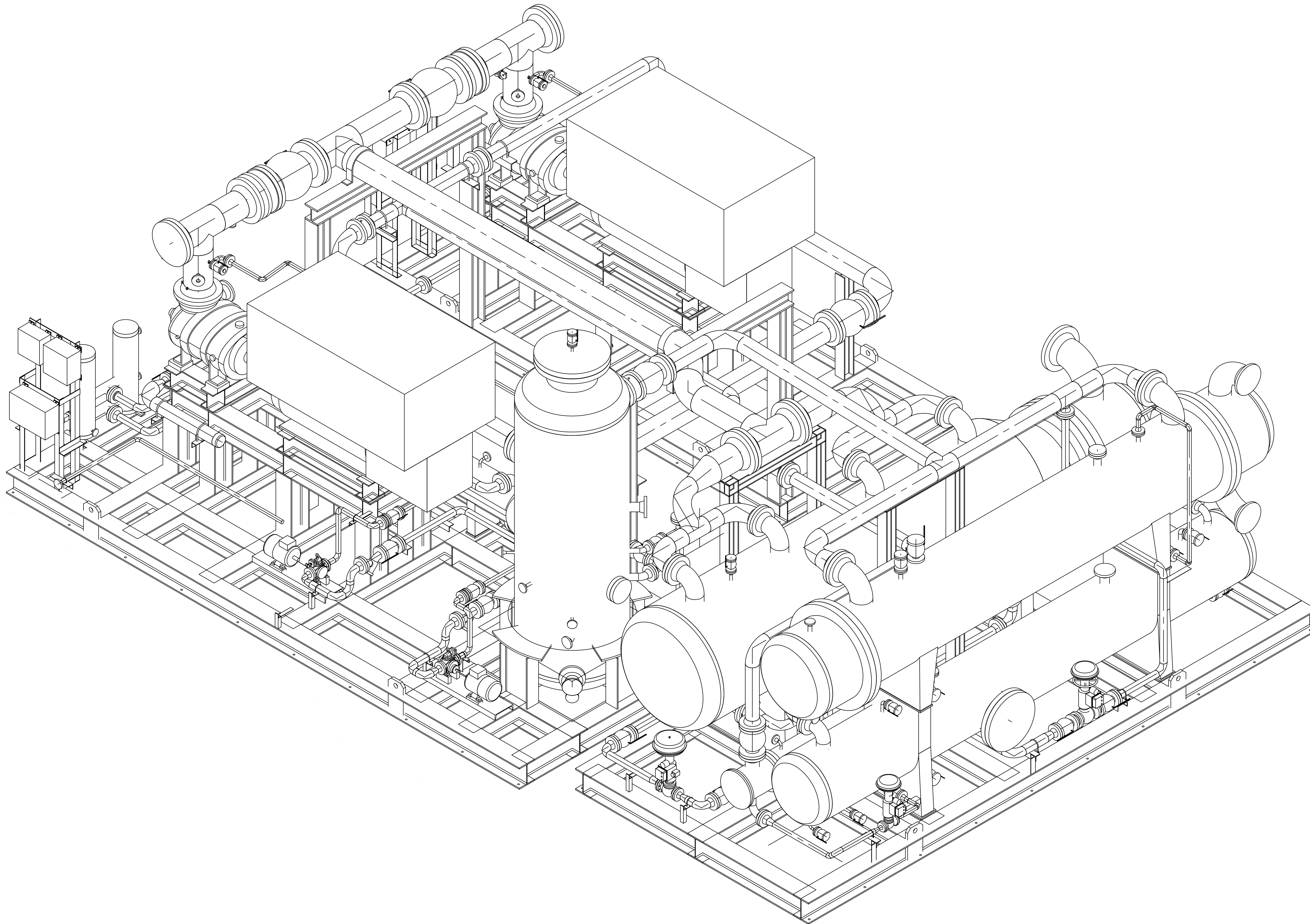





Code1	<input type="checkbox"/> No Comment/ Approved (Applicable Only for "FOR REVIEW" and "For Approval" Documents) No comment and the document are released for Manufacturing
Code2	<input type="checkbox"/> No Comment / Approved with Note(s) Vendor/Sub-Contractor shall correct, revise and resubmit the document. The document is released for Manufacturing if changes incorporated.
Code3	<input type="checkbox"/> Commented Vendor/Sub-Contractor shall correct, revise and resubmit the document by the date specified. The document shall be revised under the Status of "R: Revised Issue". All corrected documents shall be resubmitted before starting the Manufacturing Process
Code4	<input type="checkbox"/> Not Accepted (Rejected) Vendor/Sub-Contractor shall re-work/re-design/re-specify the contents of the document according to the comments/reasons for rejection. All corrected documents shall be resubmitted before starting the manufacturing. Vendor Sub-Contractor shall not proceed with subsequent works of Material Supply or Manufacturing until receiving Code1/Code2 or No Code from PURCHASER. Vendor/Sub-Contractor shall resubmit the document with the same revision within 6 working days after receiving comments
No Code	<input type="checkbox"/> No Code (Only for "For Information" Documents and "As Built DWGs") Document has been submitted for PURCHASER'S Information (I). Consistency, completeness and correctness of document content is in Vendor/Sub-Contractor's responsibility.

The above checking result by EIED shall in no way relieve Vendor of any liability, obligation and responsibility out of the purchase order and the mutual agreement in writing



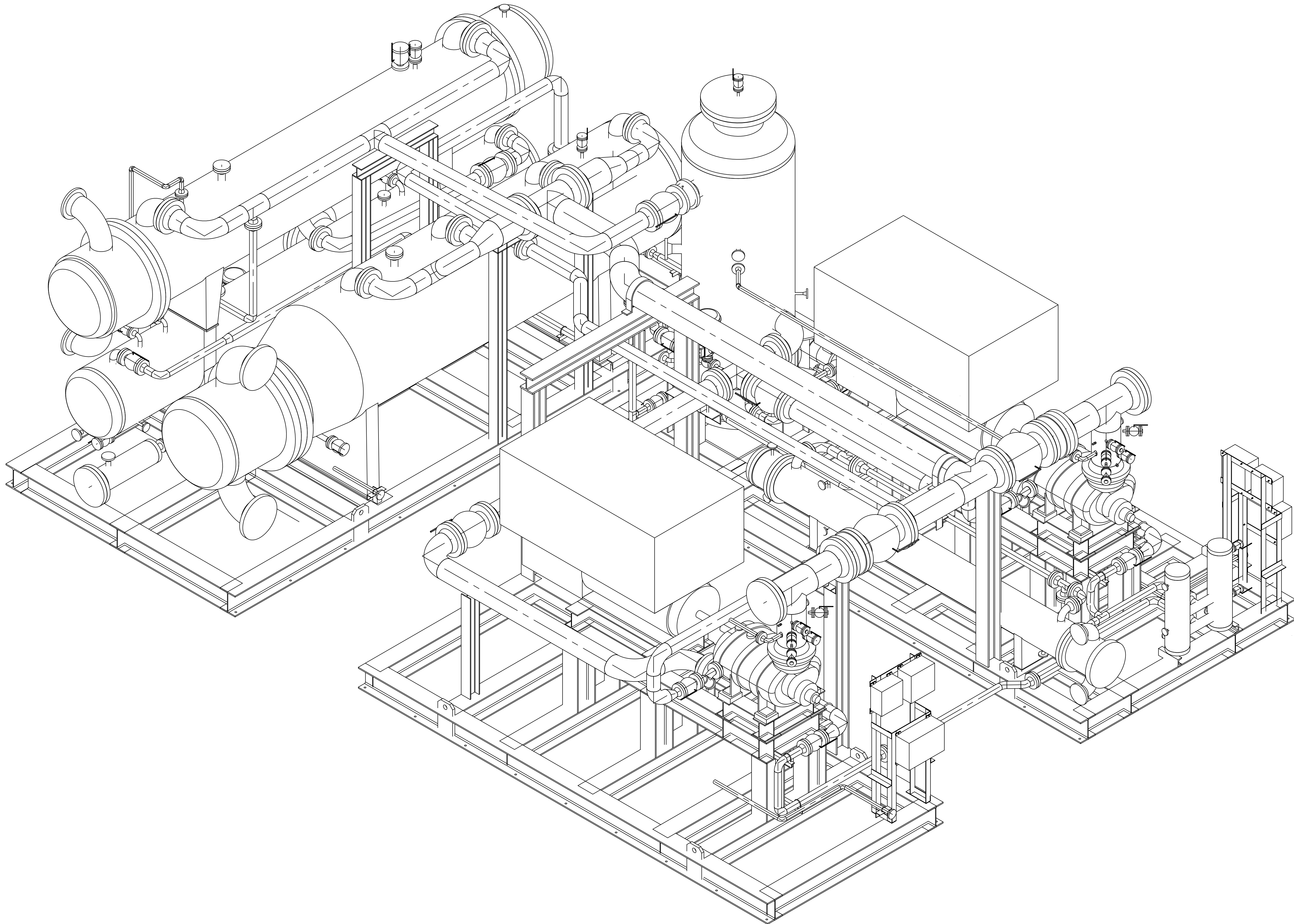

 DATE : _____
 DEPT: _____
 Signature : _____

CV	PI	EL	IN	ME	MA
ST	BU	FR	SA	HV	TL

00	28-06-2025	IFR	FA	IM	OG
REV.	DATE (DD.MM.YY)	Purpose of Issue	Prepared	Checked	Approved
 		Gacharan Plyomer Industries Company HDPE Plant			 
CONTRACT NO.: GPI-CON-99-008		SCALE: 1:1			
DRAWING TITLE: General Arrangement Drawing (2D) (*Tie-In Points, Skid Dimensions & Orientation, Including Instrument, Junction Box and Local Panel Location Layout & Instrument Cable routing) for Refrigerator Package					
DRAWING NO.	VD-GPIC-MA-3029- 0062	REV.	SHEET NO.	SIZE	
			9 of 11	A1	



Code1	<input type="checkbox"/> No Comment/ Approved (Applicable Only for "FOR REVIEW" and "For Approval" Documents) No comment and the document are released for Manufacturing				
Code2	<input type="checkbox"/> No Comment / Approved with Note(s) Vendor/Sub-Contractor shall correct, revise and resubmit the document. The document is released for Manufacturing if changes incorporated.				
Code3	<input type="checkbox"/> Commented Vendor/Sub-Contractor shall correct, revise and resubmit the document by the date specified. The document shall be revised under the Status of "R: Revised Issue". All corrected documents shall be resubmitted before starting the Manufacturing Process				
Code4	<input type="checkbox"/> Not Accepted (Rejected) Vendor/Sub-Contractor shall re-work/re-design/re-specify the contents of the document according to the comments/reasons for rejection. All corrected documents shall be resubmitted before starting the manufacturing. Vendor Sub-Contractor shall not proceed with subsequent works of Material Supply or Manufacturing until receiving Code1/Code2 or No Code from PURCHASER. Vendor/Sub-Contractor shall resubmit the document with the same revision within 6 working days after receiving comments				
No Code	<input type="checkbox"/> No Code (Only for "For Information" Documents and "As Built DWGs") Document has been submitted for PURCHASER'S information (I). Consistency, completeness and correctness of document content is in Vendor/Sub-Contractor's responsibility. The above checking result by EIED shall in no way relieve Vendor of any liability, obligation and responsibility out of the purchase order and the mutual agreement in writing				
 DATE : _____ DEPT: _____ Signature : _____					
CV	PI	EL	IN	ME	MA
ST	BU	FR	SA	HV	TL

00	28-06-2025	IFR	FA	IM	OG
REV.	DATE (DD.MM.YY)	Purpose of Issue	Prepared	Checked	Approved
 		Gacharan Polymer Industries Company HDPE Plant		 	
CONTRACT NO.: GPI-CON-99-008			SCALE: 1:1		
DRAWING TITLE: General Arrangement Drawing (2D) (*Tie-In Points, Skid Dimensions & Orientation, Including Instrument, Junction Box and Local Panel Location Layout & Instrument Cable routing.) for Refrigerator Package					
DRAWING NO. VD-GPIC-MA-3029- 0062		REV.	SHEET NO.	SIZE	
			10 of 11	A1	

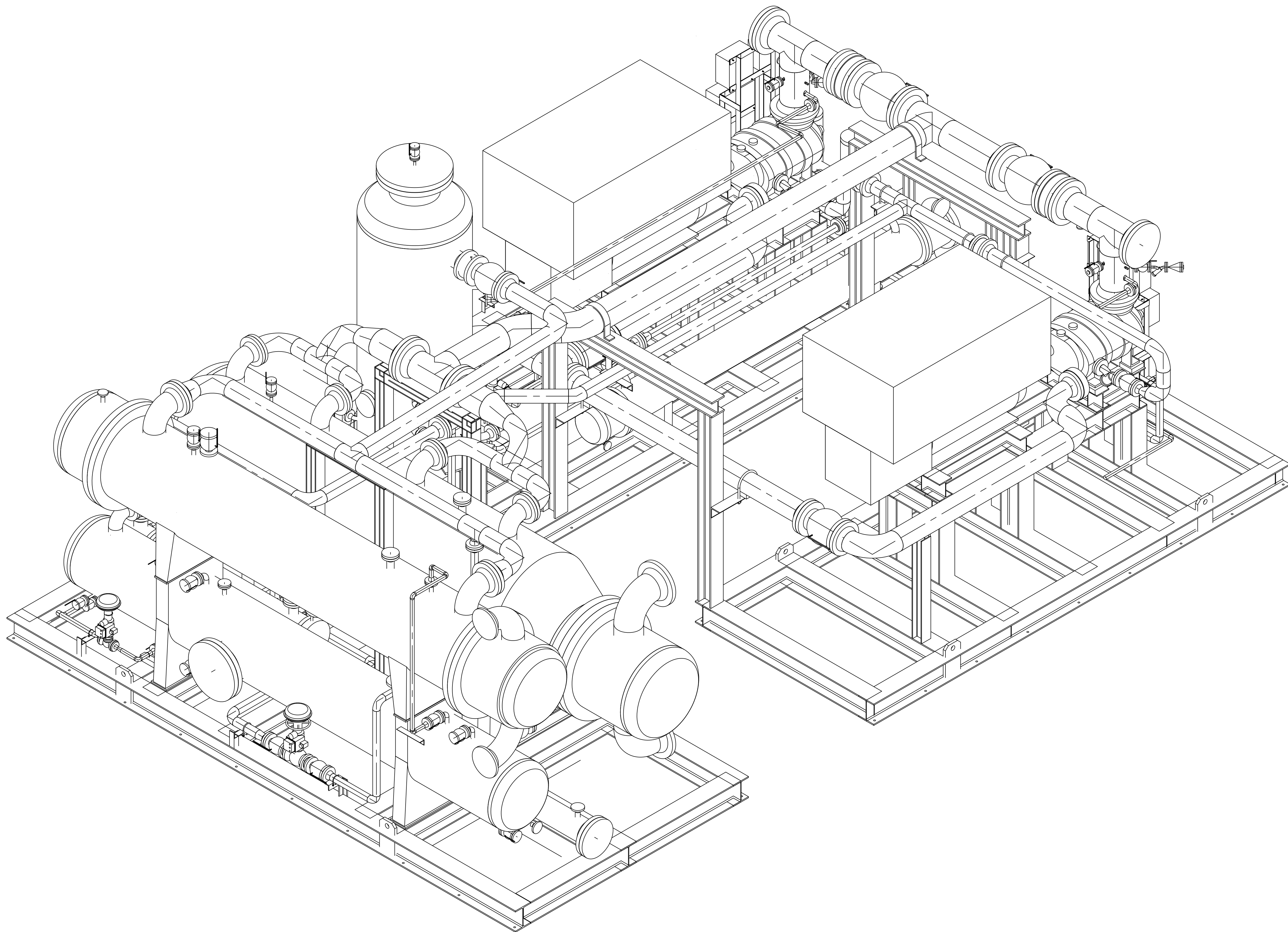

Code1 No Comment/ Approved
(Applicable Only for "FOR REVIEW" and "For Approval" Documents) No comment and the document are released for Manufacturing

Code2 No Comment / Approved with Note(s)
Vendor/Sub-Contractor shall correct, revise and resubmit the document. The document is released for Manufacturing if changes incorporated.

Code3 Commented
Vendor/Sub-Contractor shall correct, revise and resubmit the document by the date specified. The document shall be revised under the Status of "R: Revised Issue". All corrected documents shall be resubmitted before starting the Manufacturing Process

Code4 Not Accepted (Rejected)
Vendor/Sub-Contractor shall re-work/re-design/re-specify the contents of the document according to the comments/reasons for rejection. All corrected documents shall be resubmitted before starting the manufacturing. Vendor Sub-Contractor shall not proceed with subsequent works of Material Supply or Manufacturing until receiving Code1/Code2 or No Code from PURCHASER. Vendor/Sub-Contractor shall resubmit the document with the same revision within 6 working days after receiving comments

No Code No Code
(Only for "For Information" Documents and "As Built DWGs") Document has been submitted for PURCHASER's information (I). Consistency, completeness and correctness of document content is in Vendor/Sub-Contractor's responsibility.



The above checking result by EIED shall in no way relieve Vendor of any liability, obligation and responsibility out of the purchase order and the mutual agreement in writing



EIED

DATE :
DEPT:
Signature :

CV	PI	EL	IN	ME	MA
ST	BU	FR	SA	HV	TL

00	28-06-2025	IFR	FA	IM	OG
REV.	DATE (DD.MM.YY)	Purpose of Issue	Prepared	Checked	Approved



Gachasan Polymer Industries Company
HDPE Plant
 CONTRACT NO.: GPI-CON-99-008

PO No.: xxxxx SCALE: 1:1

DRAWING TITLE:
General Arrangement Drawing (2D) ("Tie-In Points, Skid Dimensions & Orientation, Including Instrument, Junction Box and Local Panel Location Layout & Instrument Cable routing.") for Refrigerator Package

DRAWING NO.	VD-GPIC-MA-3029- 0062	REV.	SHEET NO.	SIZE
			11 of 11	A1