



LIDCO, Pars SEE Zone, Assaluyeh,
Integrated Methanol and Ammonia
Plant 3000 MTPD MeOH / 900 MTPD NH3 PROJECT



Control and shut down Logic Block Diagram

Document No. 17735-32

Project No.	Vendor Doc.	P.O. No.	Department	Document Type	Serial No	Revision	Page
N278	VD	6019	EL	DIA	0049	03	Page 1 of 19

**Airpack B.V. - Air Compressor –
Integrated Methanol and Ammonia Plant
17735-COM Control and shut down Logic Block Diagram (K020)**

Code 2
M.Dalakeh

03	01-05-2024	Issued for Approval	A.Z.	S.K.	J.J.
02	09-04-2024	Issued for Approval	A.Z.	S.K.	J.J.
01	08-03-2024	Issued for Approval	A.Z.	S.K.	J.J.
REV.	DATE	DESCRIPTION	DRAWN	CHECKED	APPROVED

This document has been produced by Contractor for LIDCO. It is confidential and cannot be disclosed to or used by any third party for any purpose without prior written consent.

Control and shut down Logic Block Diagram

Document No. 17735-32

Project No.	Vendor Doc.	P.O. No.	Department	Document Type	Serial No	Revision	Page
N278	VD	6019	EL	DIA	0049	03	Page 2 of 19

LIST OF REVISED PAGES

Rev. Page	01	02	03	04	05	Rev. Page	01	02	03	04	05	Rev. Page	01	02	03	04	05	Rev. Page	01	02	03	04	05
1	X	X	X			26						51						76					
2	X	X	X			27						52						77					
3	X	X	X			28						53						78					
4	X	X	X			29						54						79					
5	X	X	X			30						55						80					
6	X	X	X			31						56						81					
7	X	X	X			32						57						82					
8	X	X	X			33						58						83					
9	X	X	X			34						59						84					
10	X	X	X			35						60						85					
11	X	X	X			36						61						86					
12	X	X	X			37						62						87					
13	X	X	X			38						63						88					
14	X	X	X			39						64						89					
15	X	X	X			40						65						90					
16	X	X	X			41						66						91					
17	X	X	X			42						67						92					
18	X	X	X			43						68						ATTACHMENT					
19	X	X	X			44						69						1					
20	X					45						70						2					
21						46						71						3					
22						47						72						4					
23						48						73						5					
24						49						74						6					
25						50						75						7					

SYMBOL	FUNCTION	DESCRIPTION
	AND	OUTPUT D EXISTS ONLY IF AND WHILE INPUTS A,B AND C EXIST.
	OR	OUTPUT D EXISTS ONLY IF AND WHILE ONE OR MORE OF INPUTS A,B OR C EXIST.
	XOR	OUTPUT D EXISTS ONLY IF AND WHILE ONE OF INPUTS A,B OR C EXIST.
	NOT	OUTPUT B EXISTS ONLY IF AND WHILE INPUT A DOES NOT EXIST.
	COMPARE	COMPARE FUNCTION THAT COMPARES THE VALUES IN X AND Y, AND IF THE COMPARISON INDICATED BY "TYPE" IS TRUE, OUTPUT A EXISTS. VALID COMPARISONS ARE: GREATER THAN(>), LESS THAN(<), EQUAL TO(==), GREATER THAN OR EQUAL TO (>=) AND LESS THAN OR EQUAL TO (<=).
	MOVE	IF INPUT A EXISTS, THE VALUE X IS ASSIGNED TO THE VARIABLE AT THE OUTPUT Y. TYPE IS INCLUDED TO INDICATE THE TYPE OF VARIABLE. B TERMINATES IMMEDIATELY WHEN A TERMINATES.
	TIMER (DELAY INITIATION)	THE CONTINUOUS EXISTENCE OF INPUT A FOR TIME T CAUSES OUTPUT B TO EXIST WHEN THE TIME T EXPIRES. B TERMINATES IMMEDIATELY WHEN A TERMINATES.
	TIMER (DELAY TERMINATION)	THE EXISTENCE OF INPUT A CAUSES OUTPUT B TO EXIST IMMEDIATELY. B TERMINATES WHEN A HAS TERMINATED AND HAS NOT AGAIN EXISTED FOR TIME T.
	PULSE OUTPUT	THE EXISTENCE OF INPUT A CAUSES OUTPUT B TO EXIST IMMEDIATELY. B EXISTS FOR TIME T, REGARDLESS OF THE STATE OF A.
	FLIP-FLOP MEMORY (SET PRIORITY)	OUTPUT C EXISTS AS SOON AS A EXISTS. C CONTINUES TO EXIST, REGARDLESS OF THE SUBSEQUENT STATE OF A, UNTIL THE MEMORY IS RESET (I.E; TERMINATED BY B EXISTING) C REMAINS TERMINATED, REGARDLESS OF THE SUBSEQUENT STATE OF B, UNTIL A CAUSES THE MEMORY TO BE SET. IF A AND B EXIST SIMULTANEOUSLY, A OVERRIDES B.
	FLIP-FLOP MEMORY (RESET PRIORITY)	OUTPUT C EXISTS AS SOON AS A EXISTS. C CONTINUES TO EXIST, REGARDLESS OF THE SUBSEQUENT STATE OF A, UNTIL THE MEMORY IS RESET (I.E; TERMINATED BY B EXISTING) C REMAINS TERMINATED, REGARDLESS OF THE SUBSEQUENT STATE OF B, UNTIL A CAUSES THE MEMORY TO BE SET. IF A AND B EXIST SIMULTANEOUSLY, B OVERRIDES A.
	RISING TRIGGER	THE EXISTENCE OF INPUT A CAUSES OUTPUT B TO EXIST IMMEDIATELY, AND FALL AWAY ON THE NEXT INSTRUCTION CYCLE.
		LOGIC CONNECTION, BRANCH
		NO CONNECTION, JUMP
		MODBUS CONNECTION

SYMBOL	DESCRIPTION
	EMERGENCY PUSHBUTTON, RED HEAD, STAY PUT.
	TWO WAY SWITCH
	THREE WAY SWITCH
	PUSHBUTTON MOMENTARILY MAKE
	PUSHBUTTON MOMENTARILY BREAK
	CONTACT NORMALLY OPEN
	CONTACT NORMALLY CLOSED
	HARDWIRED INPUT/OUTPUT
	SOLENOID VALVE, 3-WAY
	DCS CONTROL SYSTEM
	PLC CONTROL SYSTEM
	LAMP
	HMI
	AUDIBLE ALARM
	RELAY COIL

GENERAL NOTES

- THIS LOGIC DIAGRAM PROVIDES THE DETAILED OPERATION OF COMPRESSOR K020.
- SHUTDOWN CONDITION ;
0 = SHUTDOWN 1 = OPERATING
- ALARM/TRIP CONDITION ;
0 = ALARM 1=NORMAL
0 = TRIP 1=NORMAL

ABBREVIATIONS

DCS : DISTRIBUTED CONTROL SYSTEM
MCC : MOTOR CONTROL CENTER
LPS : LOCAL PANEL STATION
I/P : HARDWIRED INPUT
O/P : HARDWIRED OUTPUT

DEFINITION

- AVAILABLE: COMPRESSOR READY TO START.
- RUNNING: PACKAGE RUNNING.
- LOGIC CONTINUATION FROM/TO OTHER SHEET

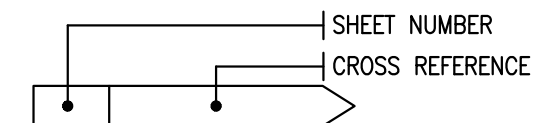

REFERENCE DOCUMENTS

- Piping & Instrument Diagram
- Cause & Effect Chart
- Control philosophy and Interlock Description
- I/O List

SH 1



SUBJECT	LOGIC DIAGRAM	DATE	08-03-2024	THIS DRAWING IS OWNED BY AIRPACK AND SHALL NOT BE PRINTED OR COPIED IN ANY OTHER WAY THAN WITH AIRPACKS PERMISSION			
	HIGH PRESSURE AIR COMPRESSOR K020	DRAWN BY	AZ				
CLIENT	Lavan Industry Development Company	CHECKED BY	SK				
CLIENT REF	N-278-VD-6019-EL-DIA-0049	PLANT LOCATION	IRAN, ONSHORE		03	01-05-2024	AZ
AIRPACK REF	17735-COM	DRAWING NO.	17735-32		02	09-04-2024	AZ
		SHEET NO.	01 / 17		01	08-03-2024	AZ

LOGIC DIAGRAM

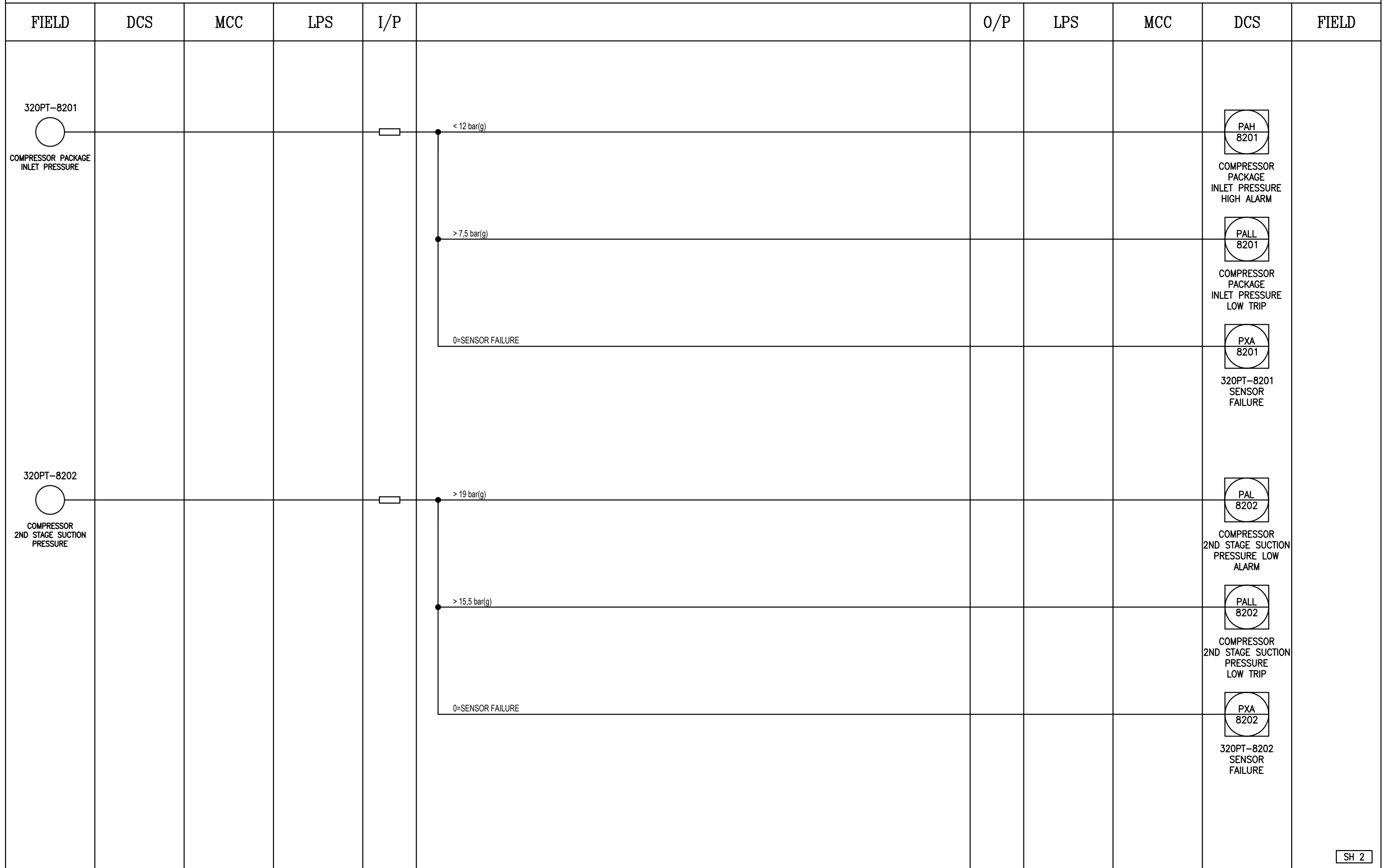

SH 2

NOTES:

1. -



SUBJECT		LOGIC DIAGRAM HIGH PRESSURE AIR COMPRESSOR K020		DATE	08-03-2024	THIS DRAWING IS OWNED BY AIRPACK AND SHALL NOT BE PRINTED OR COPIED IN ANY OTHER WAY THAN WITH AIRPACKS PERMISSION			
DRAWN BY		AZ		CHECKED BY	SK				
CLIENT	Lavan Industry Development Company			PLANT LOCATION	IRAN, ONSHORE				
CLIENT REF	N-278-VD-6019-EL-DIA-0049			DRAWING NO.	17735-32				
AIRPACK REF	17735-COM			SHEET NO.	02 / 17				
							03	01-05-2024	AZ
							02	09-04-2024	AZ
							01	08-03-2024	AZ

LOGIC DIAGRAM

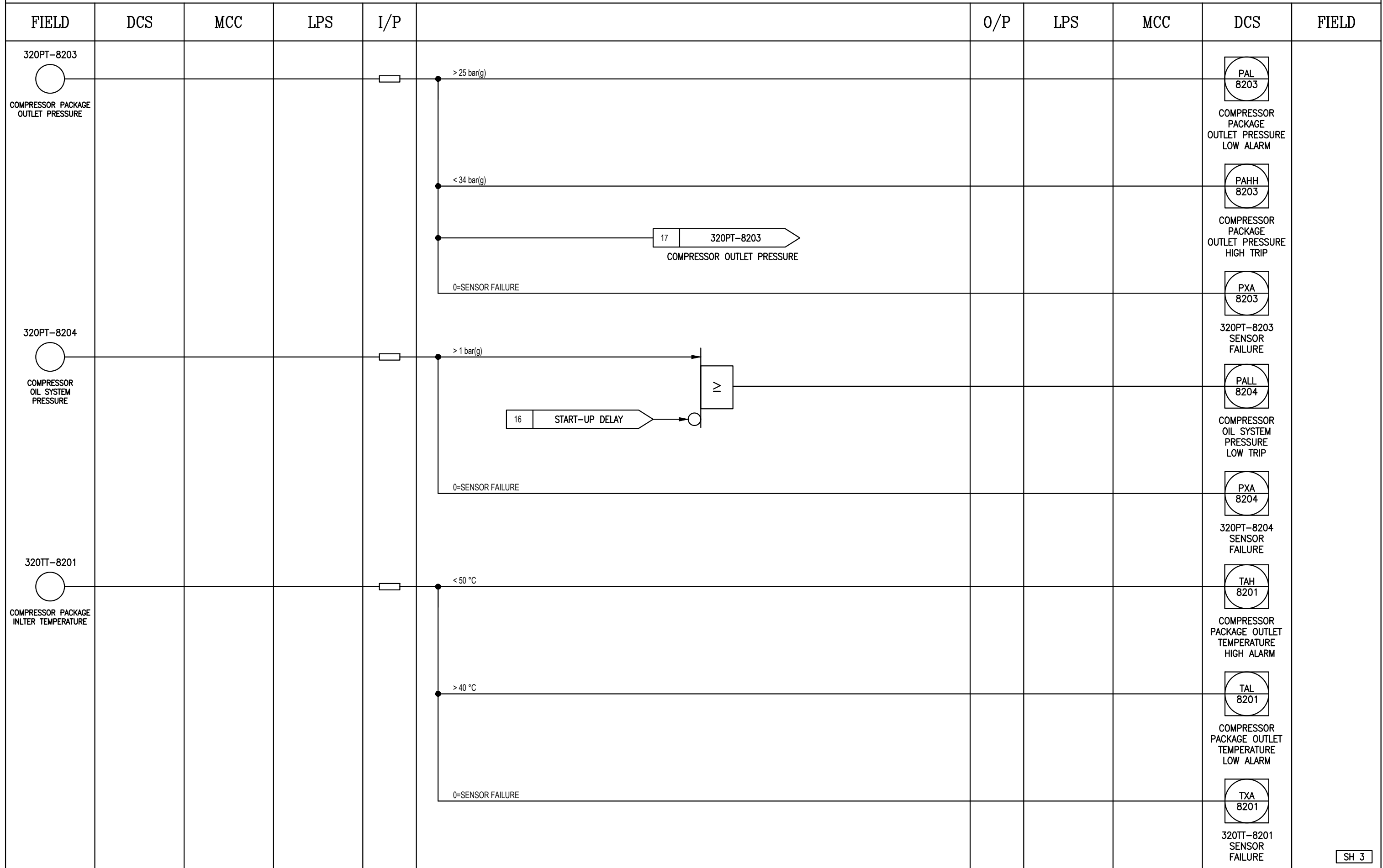

SH 3

NOTES:

1. -



SUBJECT		LOGIC DIAGRAM HIGH PRESSURE AIR COMPRESSOR K020		DATE	08-03-2024
CLIENT		Lavan Industry Development Company		DRAWN BY	AZ
CLIENT REF		N-278-VD-6019-EL-DIA-0049		CHECKED BY	SK
AIRPACK REF		17735-COM		PLANT LOCATION	IRAN, ONSHORE
				DRAWING NO.	17735-32
				SHEET NO.	03 / 17

THIS DRAWING IS OWNED BY AIRPACK AND SHALL NOT BE PRINTED OR COPIED IN ANY OTHER WAY THAN WITH AIRPACKS PERMISSION

03	01-05-2024	AZ
02	09-04-2024	AZ
01	08-03-2024	AZ

LOGIC DIAGRAM

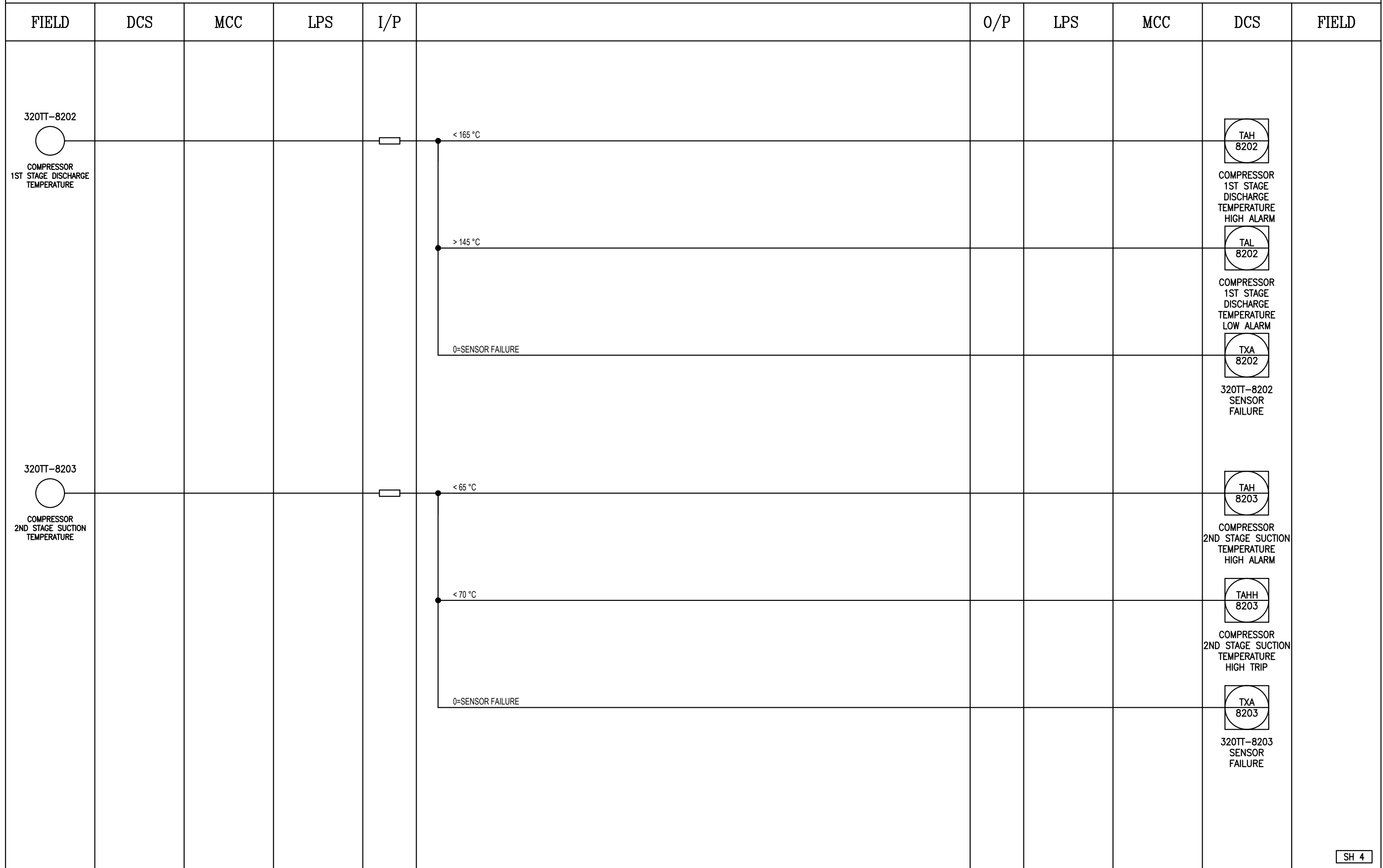

SH 4

NOTES:

1. -



SUBJECT		LOGIC DIAGRAM		DATE	08-03-2024	THIS DRAWING IS OWNED BY AIRPACK AND SHALL NOT BE PRINTED OR COPIED IN ANY OTHER WAY THAN WITH AIRPACKS PERMISSION			
		HIGH PRESSURE AIR COMPRESSOR K020		DRAWN BY	AZ				
				CHECKED BY	SK				
CLIENT	Lavan Industry Development Company			PLANT LOCATION	IRAN, ONSHORE				
CLIENT REF	N-278-VD-6019-EL-DIA-0049			DRAWING NO.	17735-32		03	01-05-2024	AZ
AIRPACK REF	17735-COM			SHEET NO.	04 / 17		02	09-04-2024	AZ
							01	08-03-2024	AZ

LOGIC DIAGRAM

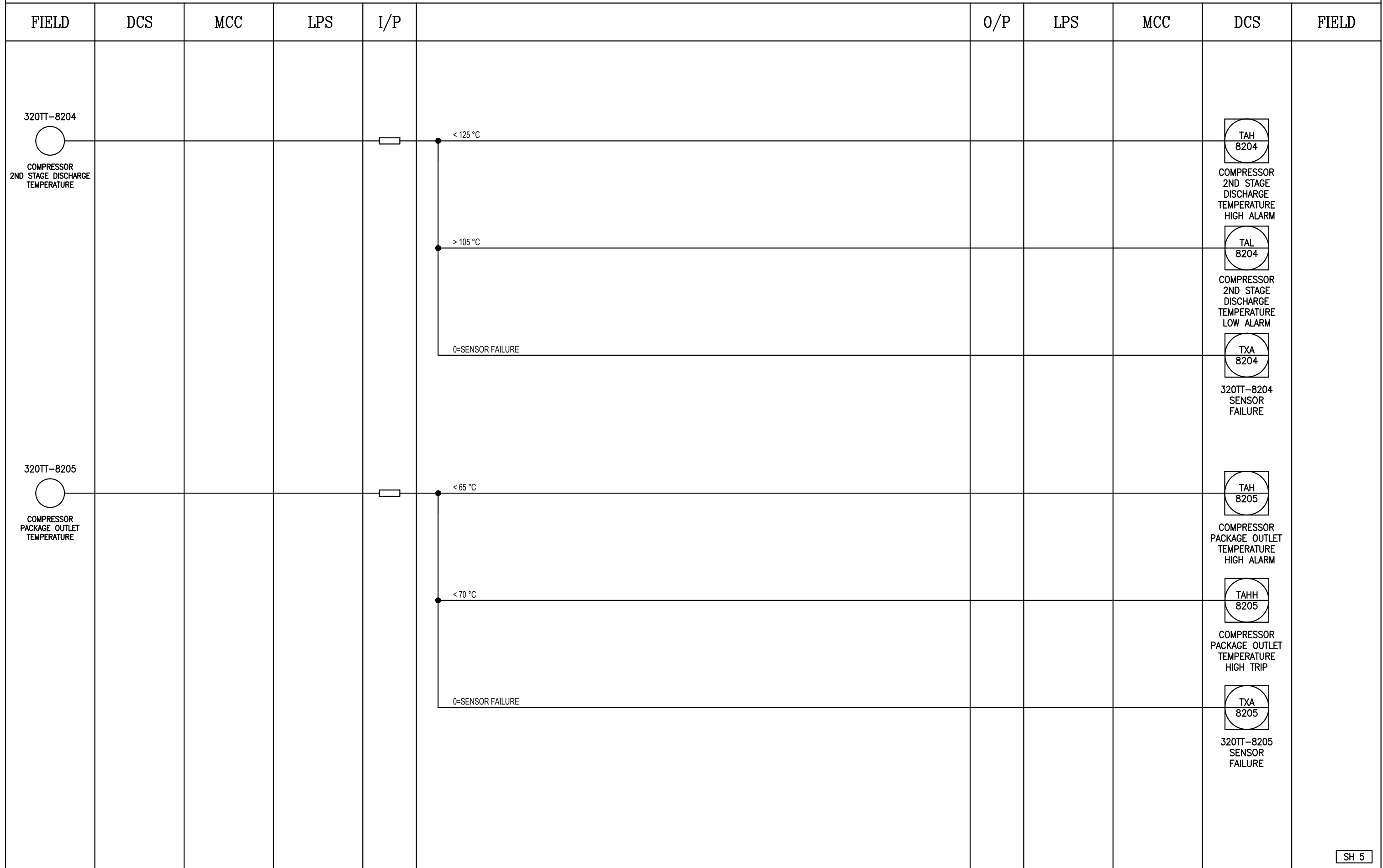

SH 5

NOTES:

1. -



SUBJECT		LOGIC DIAGRAM		DATE	08-03-2024	THIS DRAWING IS OWNED BY AIRPACK AND SHALL NOT BE PRINTED OR COPIED IN ANY OTHER WAY THAN WITH AIRPACKS PERMISSION			
		HIGH PRESSURE AIR COMPRESSOR K020		DRAWN BY	AZ				
				CHECKED BY	SK				
CLIENT	Lavan Industry Development Company			PLANT LOCATION	IRAN, ONSHORE				
CLIENT REF	N-278-VD-6019-EL-DIA-0049			DRAWING NO.	17735-32		03	01-05-2024	AZ
AIRPACK REF	17735-COM			SHEET NO.	05 / 17		02	09-04-2024	AZ
							01	08-03-2024	AZ

LOGIC DIAGRAM

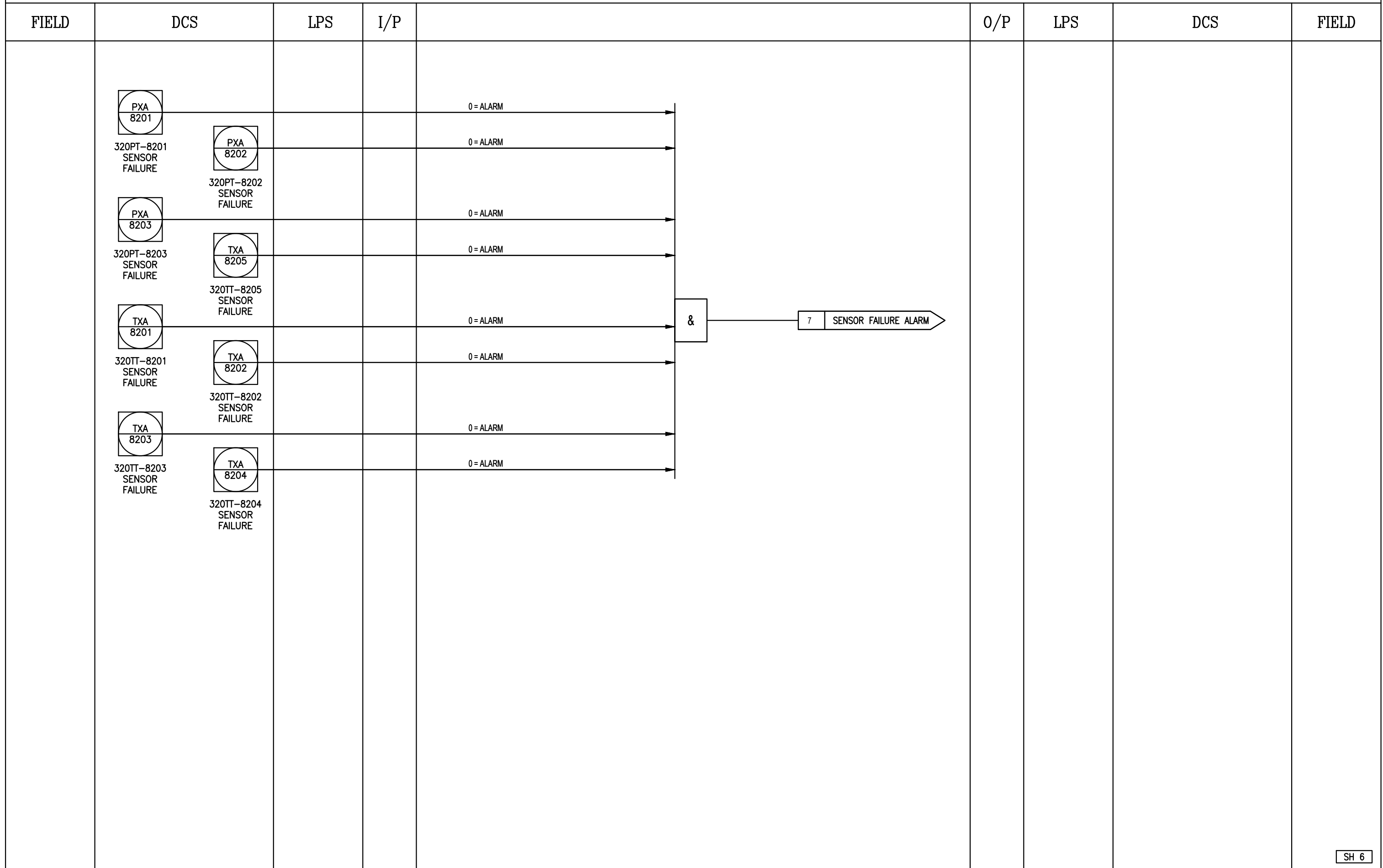

SH 6

NOTES:

-



SUBJECT		LOGIC DIAGRAM		DATE	08-03-2024
		HIGH PRESSURE AIR COMPRESSOR		DRAWN BY	AZ
		K020		CHECKED BY	SK
CLIENT	Lavan Industry Development Company			PLANT LOCATION	IRAN, ONSHORE
CLIENT REF	N-278-VD-6019-EL-DIA-0049			DRAWING NO.	17735-32
AIRPACK REF	17735-COM			SHEET NO.	06 / 17

THIS DRAWING IS OWNED BY AIRPACK AND SHALL NOT BE PRINTED OR COPIED IN ANY OTHER WAY THAN WITH AIRPACKS PERMISSION

03	01-05-2024	AZ
02	09-04-2024	AZ
01	08-03-2024	AZ

LOGIC DIAGRAM

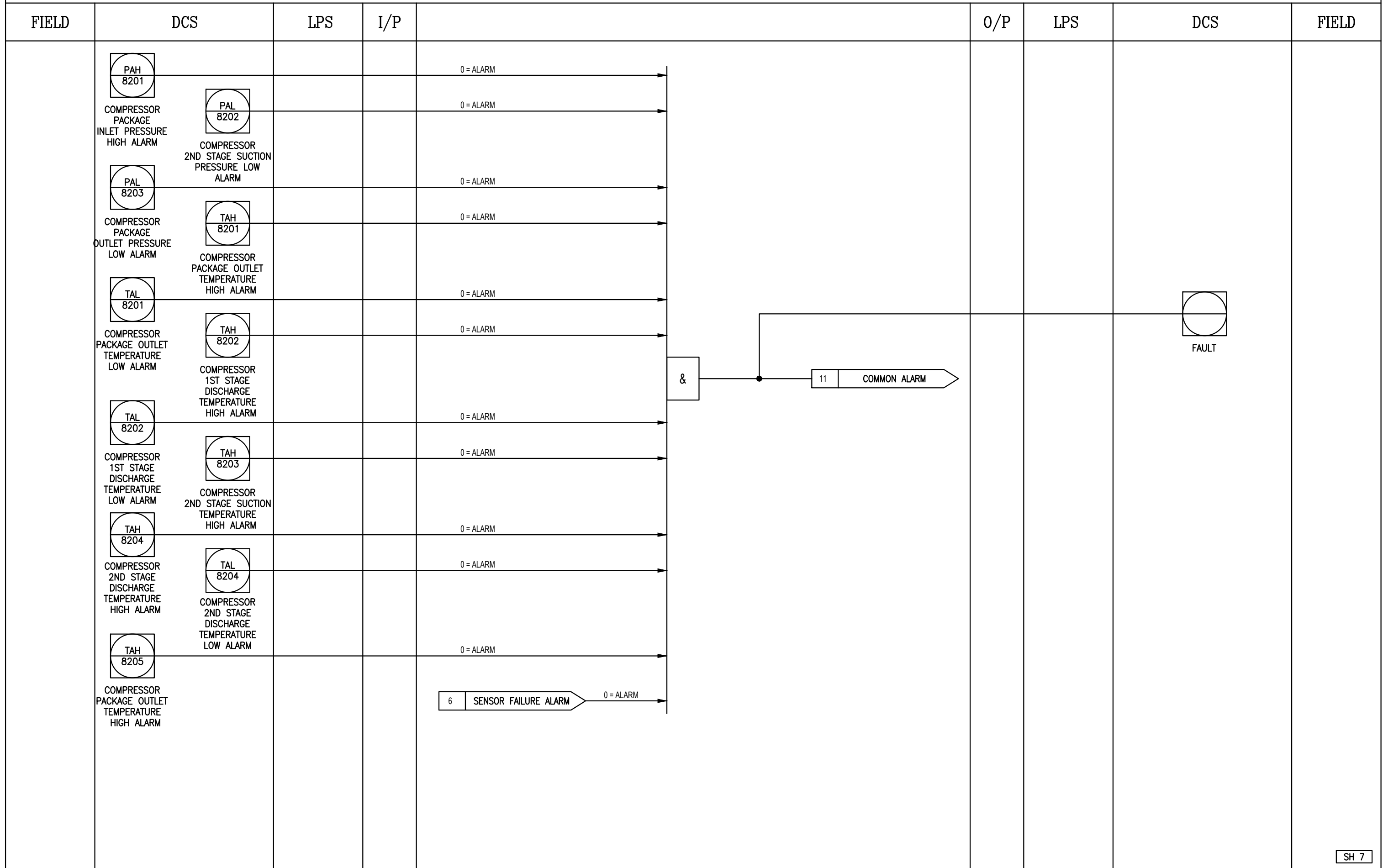

SH 7

NOTES:

1. -



SUBJECT		LOGIC DIAGRAM HIGH PRESSURE AIR COMPRESSOR K020	
CLIENT	Lavan Industry Development Company	DATE	08-03-2024
CLIENT REF	N-278-VD-6019-EL-DIA-0049	DRAWN BY	AZ
AIRPACK REF	17735-COM	CHECKED BY	SK
		PLANT LOCATION	IRAN, ONSHORE
		DRAWING NO.	17735-32
		SHEET NO.	07 / 17

THIS DRAWING IS OWNED BY AIRPACK AND SHALL NOT BE PRINTED OR COPIED IN ANY OTHER WAY THAN WITH AIRPACKS PERMISSION			
03	01-05-2024	AZ	
02	09-04-2024	AZ	
01	08-03-2024	AZ	

LOGIC DIAGRAM

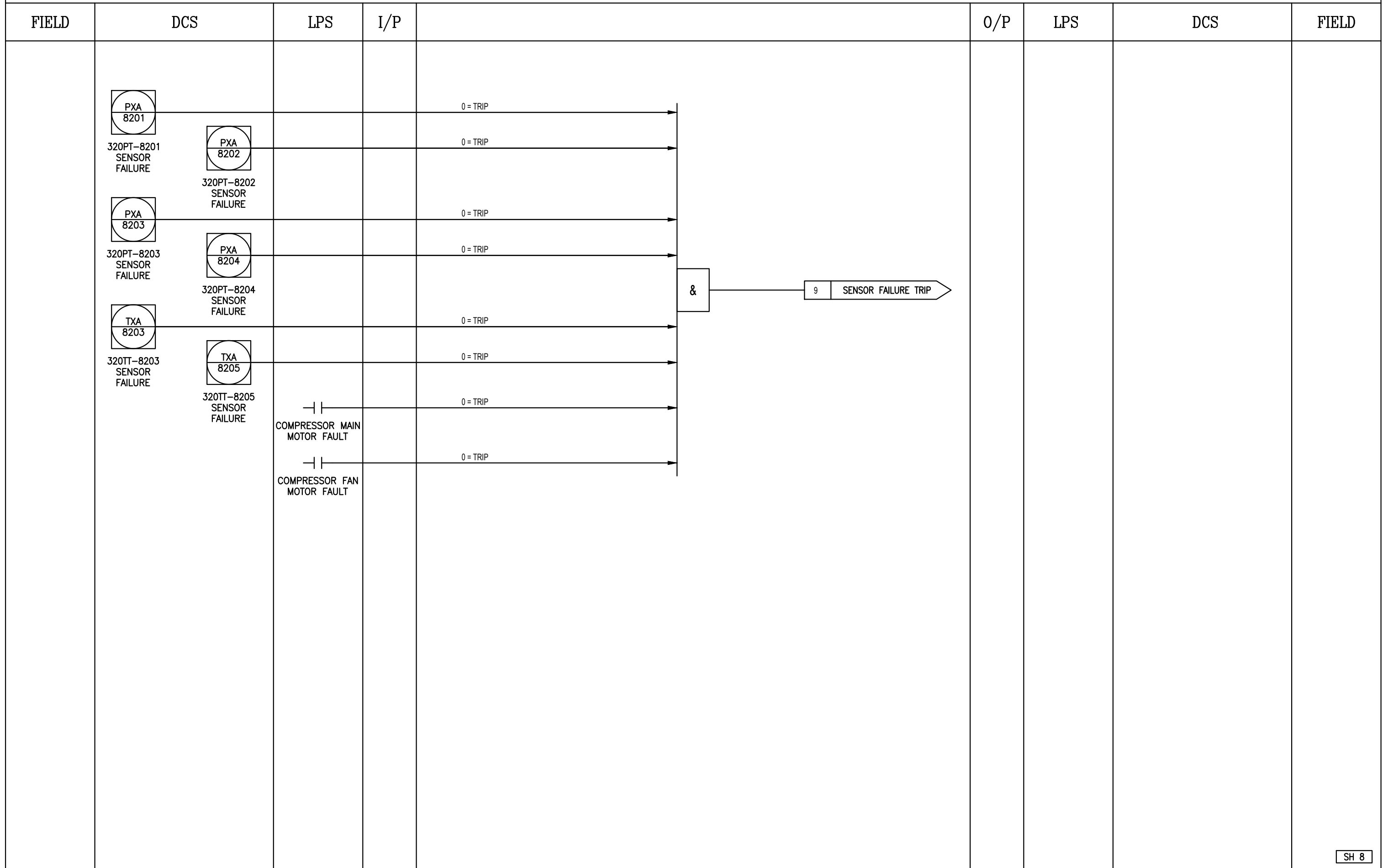

SH 8

NOTES:

1. -



SUBJECT		LOGIC DIAGRAM HIGH PRESSURE AIR COMPRESSOR K020		DATE	08-03-2024	THIS DRAWING IS OWNED BY AIRPACK AND SHALL NOT BE PRINTED OR COPIED IN ANY OTHER WAY THAN WITH AIRPACKS PERMISSION			
DRAWN BY		AZ		CHECKED BY	SK				
CLIENT	Lavan Industry Development Company			PLANT LOCATION	IRAN, ONSHORE		03	01-05-2024	AZ
CLIENT REF	N-278-VD-6019-EL-DIA-0049			DRAWING NO.	17735-32		02	09-04-2024	AZ
AIRPACK REF	17735-COM			SHEET NO.	08 / 17	01	08-03-2024	AZ	

LOGIC DIAGRAM

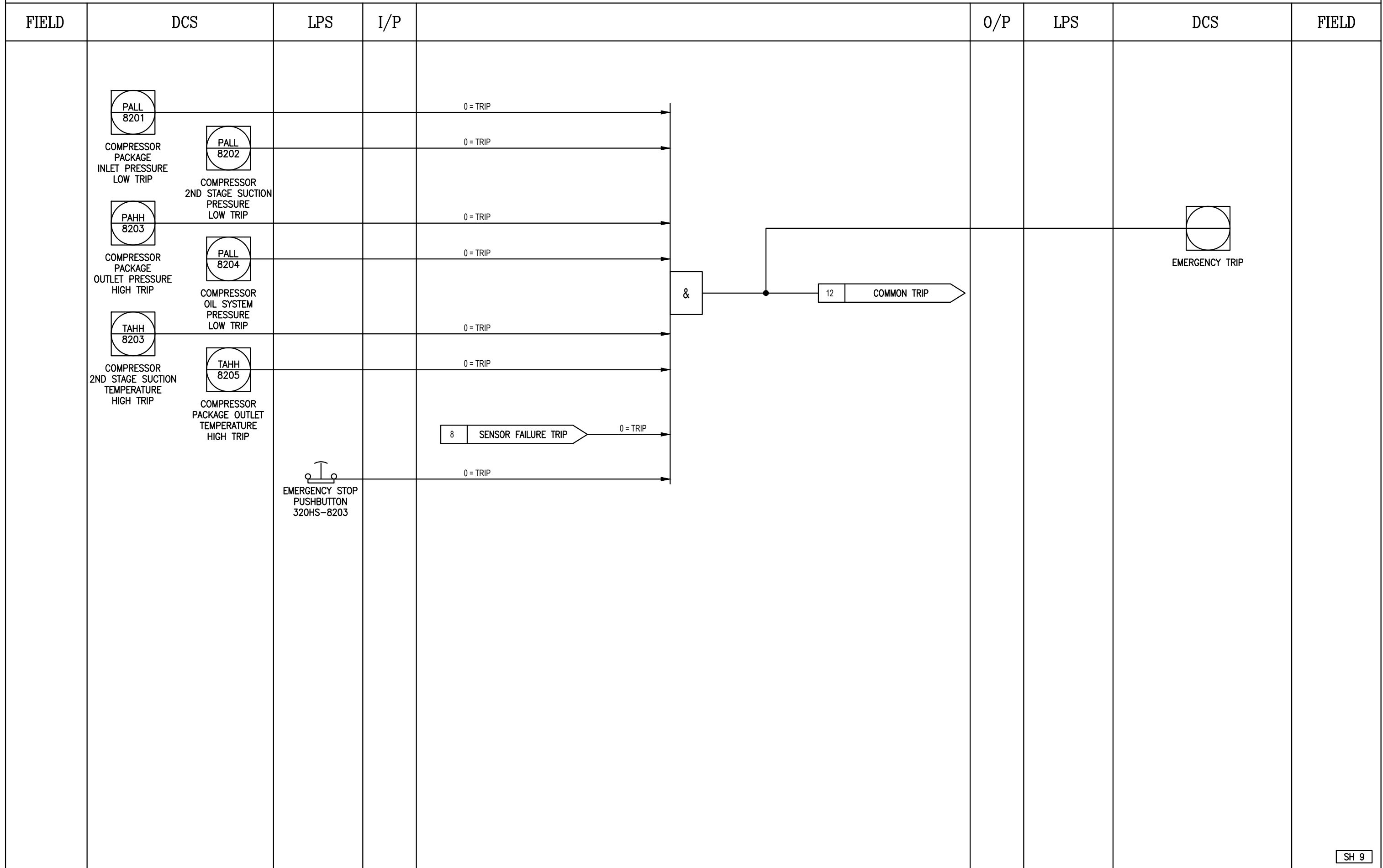

SH 9

NOTES:

1. -



SUBJECT		LOGIC DIAGRAM HIGH PRESSURE AIR COMPRESSOR K020	
CLIENT	Lavan Industry Development Company	DATE	08-03-2024
CLIENT REF	N-278-VD-6019-EL-DIA-0049	DRAWN BY	AZ
AIRPACK REF	17735-COM	CHECKED BY	SK
		PLANT LOCATION	IRAN, ONSHORE
		DRAWING NO.	17735-32
		SHEET NO.	09 / 17

THIS DRAWING IS OWNED BY AIRPACK AND SHALL NOT BE PRINTED OR COPIED IN ANY OTHER WAY THAN WITH AIRPACKS PERMISSION		
03	01-05-2024	AZ
02	09-04-2024	AZ
01	08-03-2024	AZ

LOGIC DIAGRAM

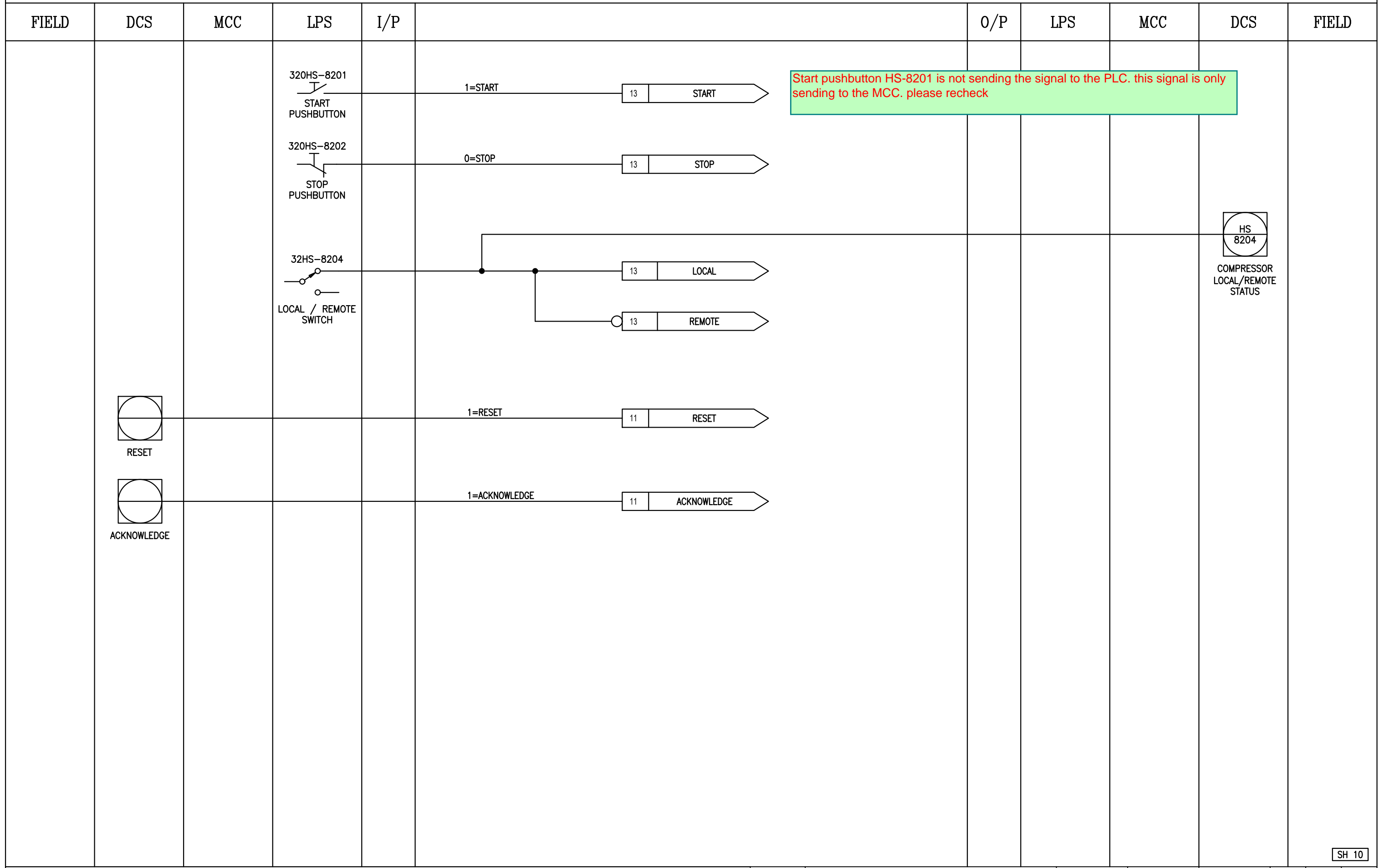

NOTES:

1. -



SUBJECT		LOGIC DIAGRAM HIGH PRESSURE AIR COMPRESSOR K020		DATE	08-03-2024
DRAWN BY		AZ		CHECKED BY	SK
CLIENT	Lavan Industry Development Company	PLANT LOCATION	IRAN, ONSHORE	THIS DRAWING IS OWNED BY AIRPACK AND SHALL NOT BE PRINTED OR COPIED IN ANY OTHER WAY THAN WITH AIRPACKS PERMISSION	
CLIENT REF	N-278-VD-6019-EL-DIA-0049	DRAWING NO.	17735-32	03	01-05-2024 AZ
AIRPACK REF	17735-COM	SHEET NO.	10 / 17	02	09-04-2024 AZ
				01	08-03-2024 AZ

LOGIC DIAGRAM

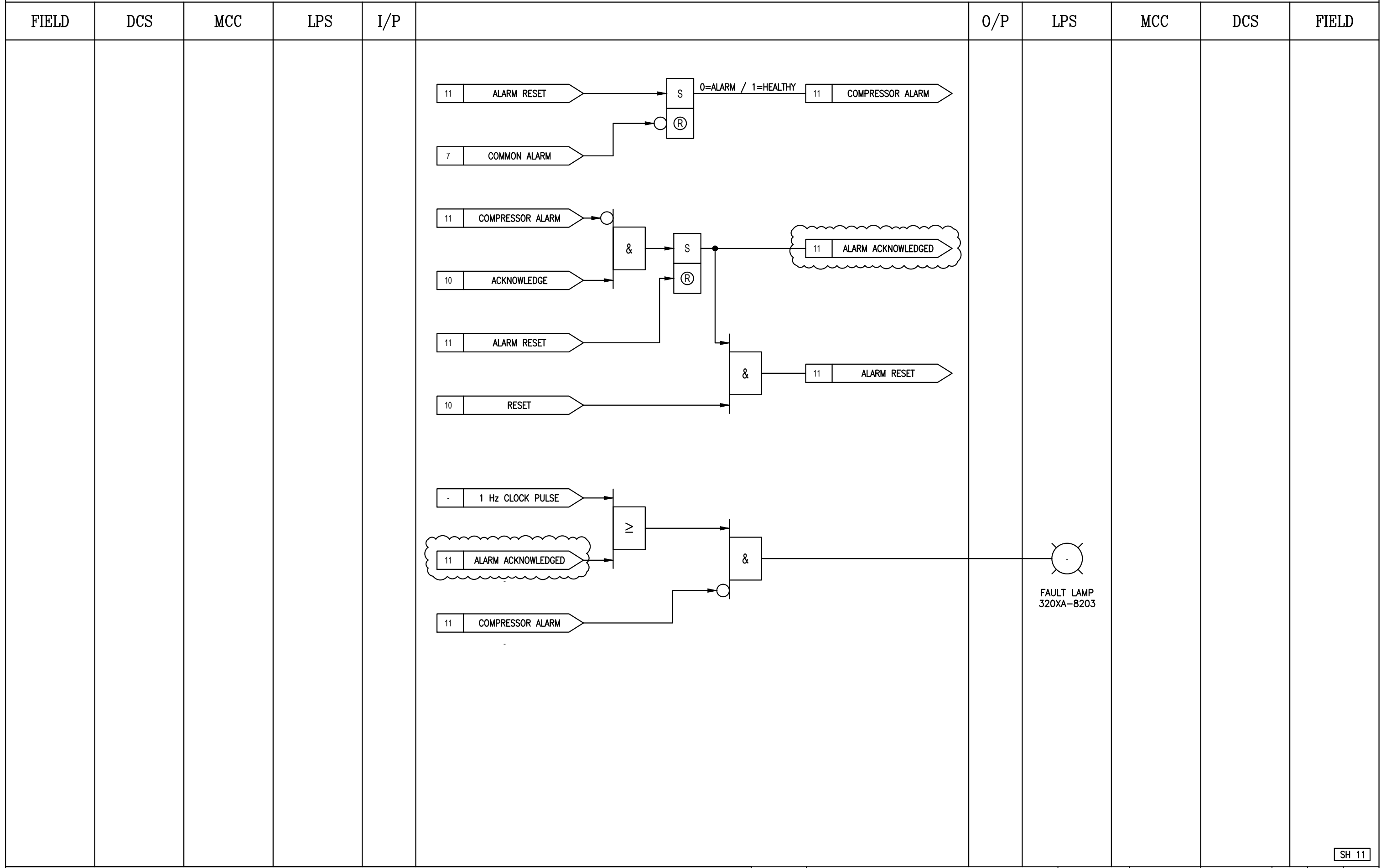

SH 11

NOTES:

1. -



SUBJECT LOGIC DIAGRAM HIGH PRESSURE AIR COMPRESSOR K020		DATE	08-03-2024	THIS DRAWING IS OWNED BY AIRPACK AND SHALL NOT BE PRINTED OR COPIED IN ANY OTHER WAY THAN WITH AIRPACKS PERMISSION			
		DRAWN BY	AZ				
CLIENT	Lavan Industry Development Company	CHECKED BY	SK				
CLIENT REF	N-278-VD-6019-EL-DIA-0049	PLANT LOCATION	IRAN, ONSHORE		03	01-05-2024	AZ
AIRPACK REF	17735-COM	DRAWING NO.	17735-32		02	09-04-2024	AZ
		SHEET NO.	11 / 17		01	08-03-2024	AZ

LOGIC DIAGRAM

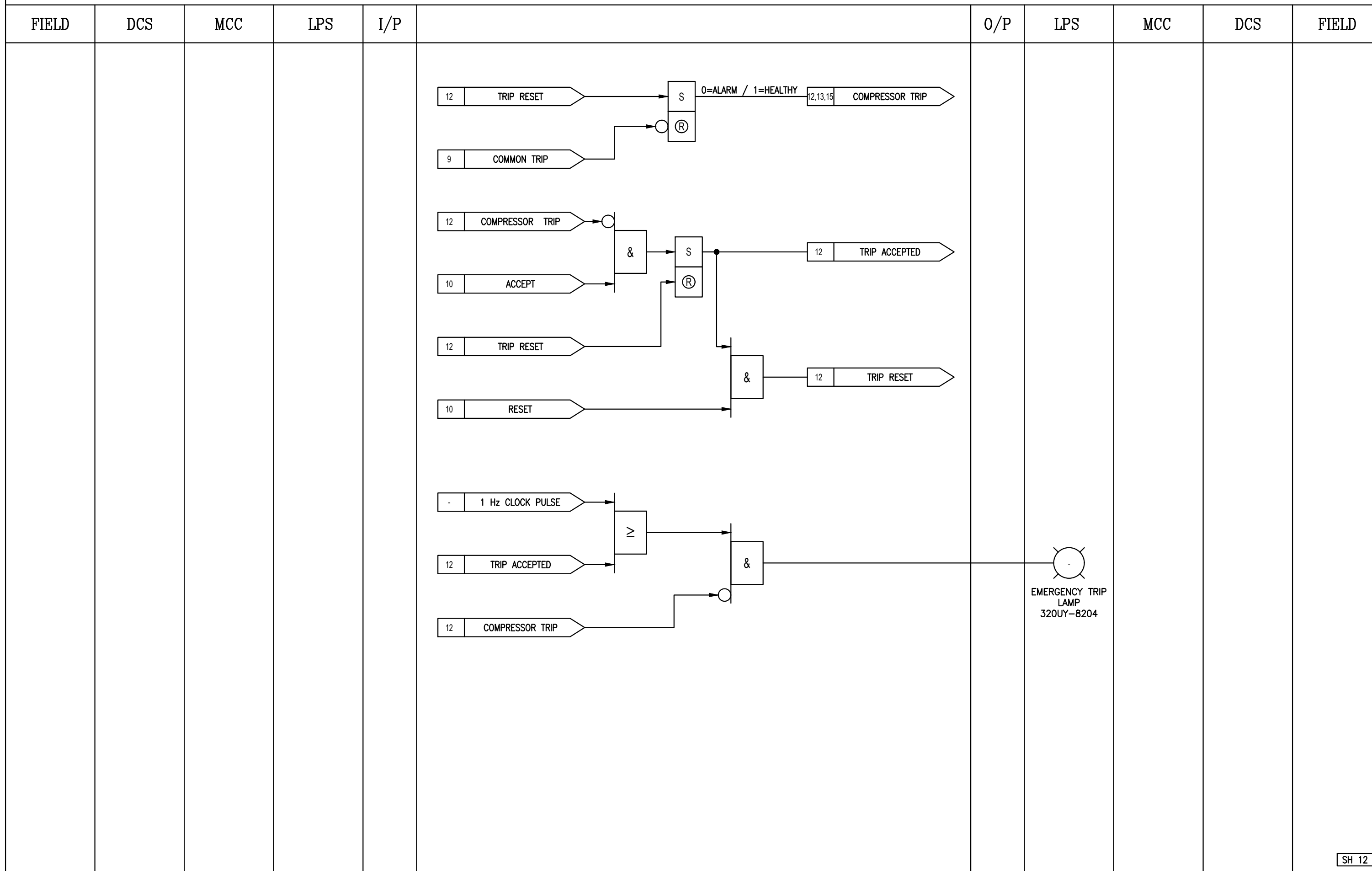

SH 12

NOTES:

-



SUBJECT LOGIC DIAGRAM HIGH PRESSURE AIR COMPRESSOR K020		DATE	08-03-2024	THIS DRAWING IS OWNED BY AIRPACK AND SHALL NOT BE PRINTED OR COPIED IN ANY OTHER WAY THAN WITH AIRPACKS PERMISSION			
		DRAWN BY	AZ				
CLIENT	Lavan Industry Development Company	CHECKED BY	SK				
CLIENT REF	N-278-VD-6019-EL-DIA-0049	PLANT LOCATION	IRAN, ONSHORE		03	01-05-2024	AZ
AIRPACK REF	17735-COM	DRAWING NO.	17735-32		02	09-04-2024	AZ
		SHEET NO.	12 / 17		01	08-03-2024	AZ

LOGIC DIAGRAM

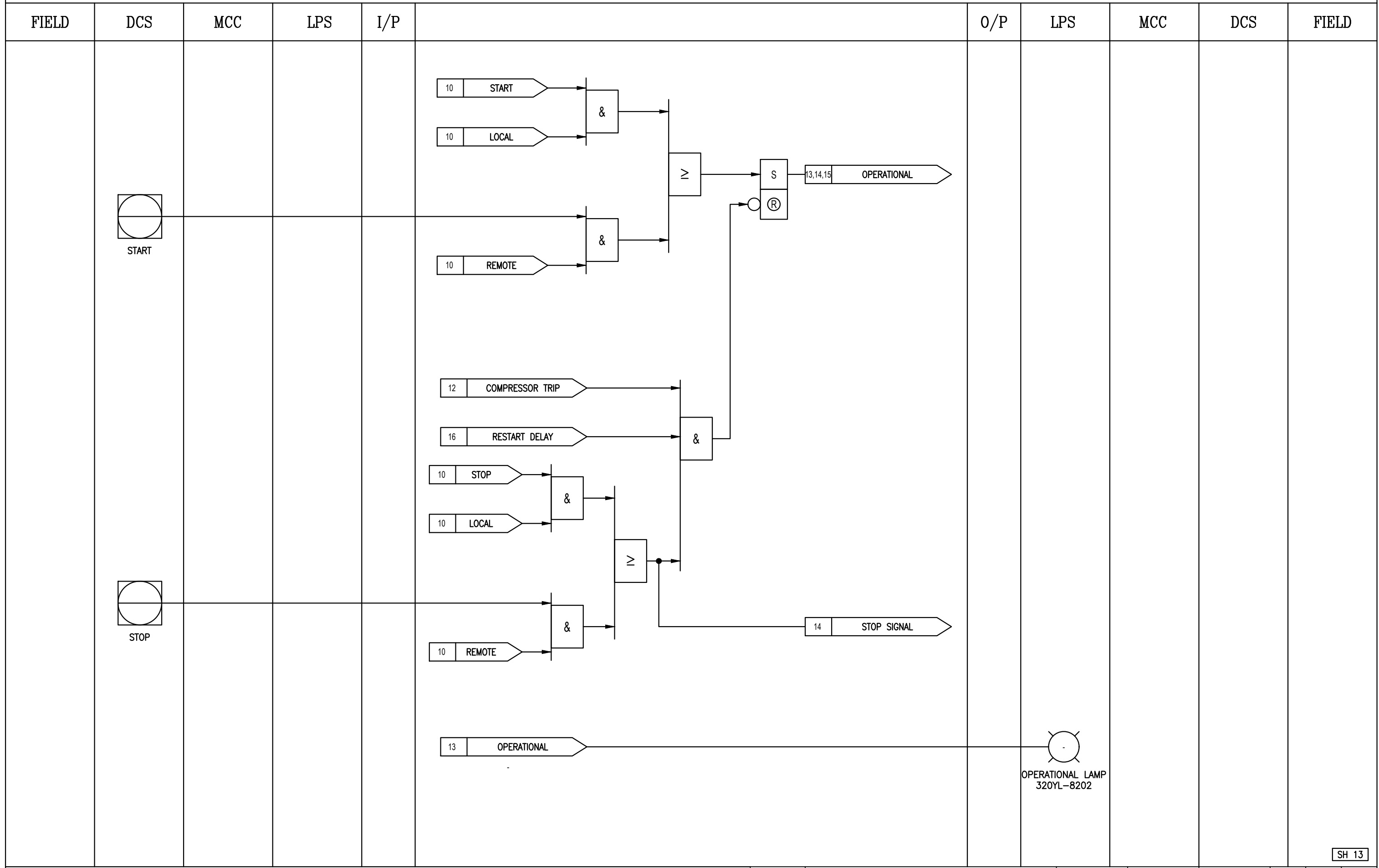

SH 13

NOTES:

1. -



SUBJECT		LOGIC DIAGRAM HIGH PRESSURE AIR COMPRESSOR K020	
CLIENT	Lavan Industry Development Company	DATE	08-03-2024
CLIENT REF	N-278-VD-6019-EL-DIA-0049	DRAWN BY	AZ
AIRPACK REF	17735-COM	CHECKED BY	SK
		PLANT LOCATION	IRAN, ONSHORE
		DRAWING NO.	17735-32
		SHEET NO.	13 / 17

THIS DRAWING IS OWNED BY AIRPACK AND SHALL NOT BE PRINTED OR COPIED IN ANY OTHER WAY THAN WITH AIRPACKS PERMISSION			
03	01-05-2024	AZ	
02	09-04-2024	AZ	
01	08-03-2024	AZ	

LOGIC DIAGRAM

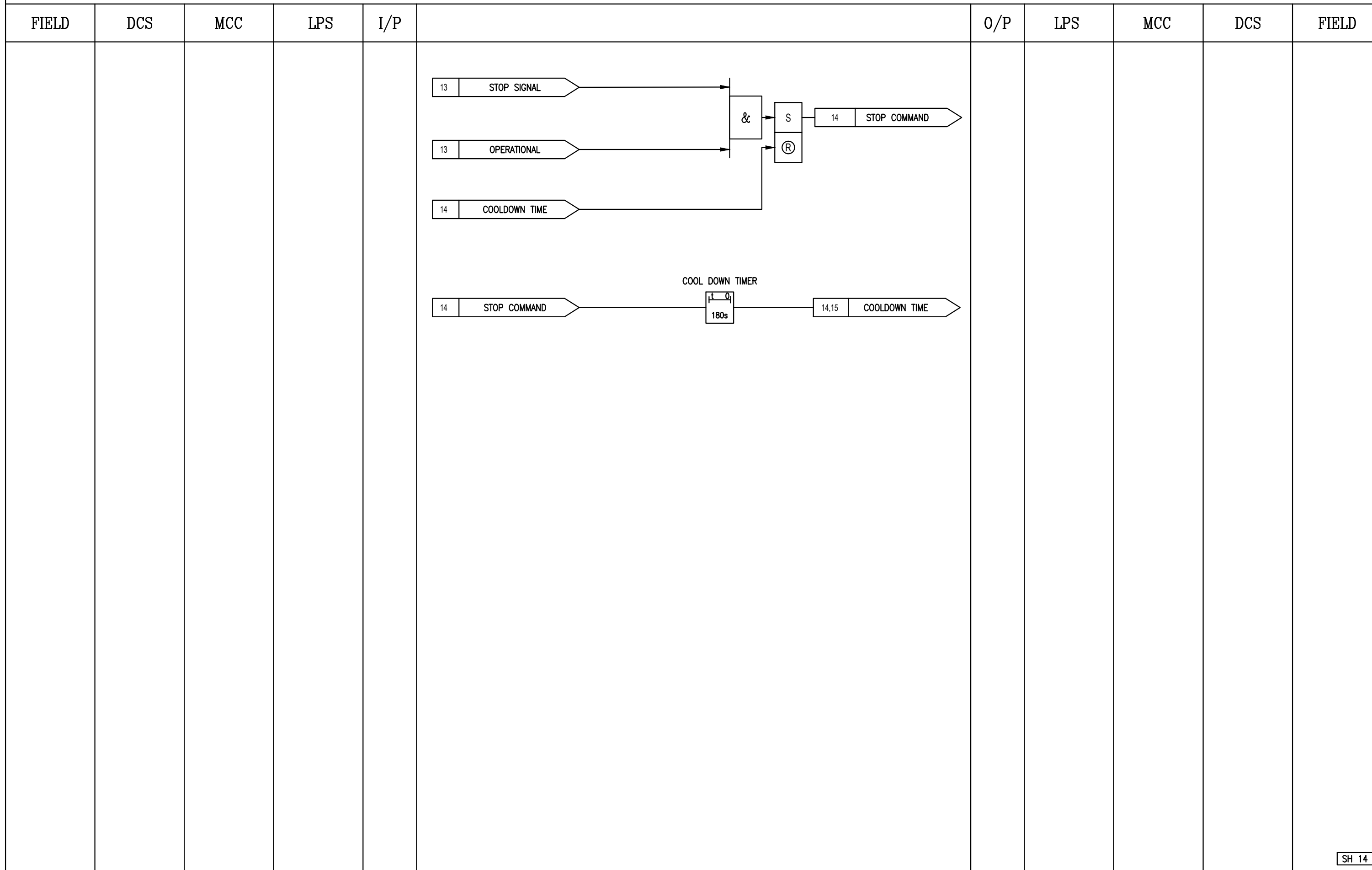

SH 14

NOTES:

1. -



SUBJECT		LOGIC DIAGRAM HIGH PRESSURE AIR COMPRESSOR K020	
CLIENT	Lavan Industry Development Company		
CLIENT REF	N-278-VD-6019-EL-DIA-0049		
AIRPACK REF	17735-COM		

DATE	08-03-2024		
DRAWN BY	AZ		
CHECKED BY	SK		
PLANT LOCATION	IRAN, ONSHORE		
DRAWING NO.	17735-32		
SHEET NO.	14 / 17		

THIS DRAWING IS OWNED BY AIRPACK AND SHALL NOT BE PRINTED OR COPIED IN ANY OTHER WAY THAN WITH AIRPACKS PERMISSION			
03	01-05-2024	AZ	
02	09-04-2024	AZ	
01	08-03-2024	AZ	

LOGIC DIAGRAM

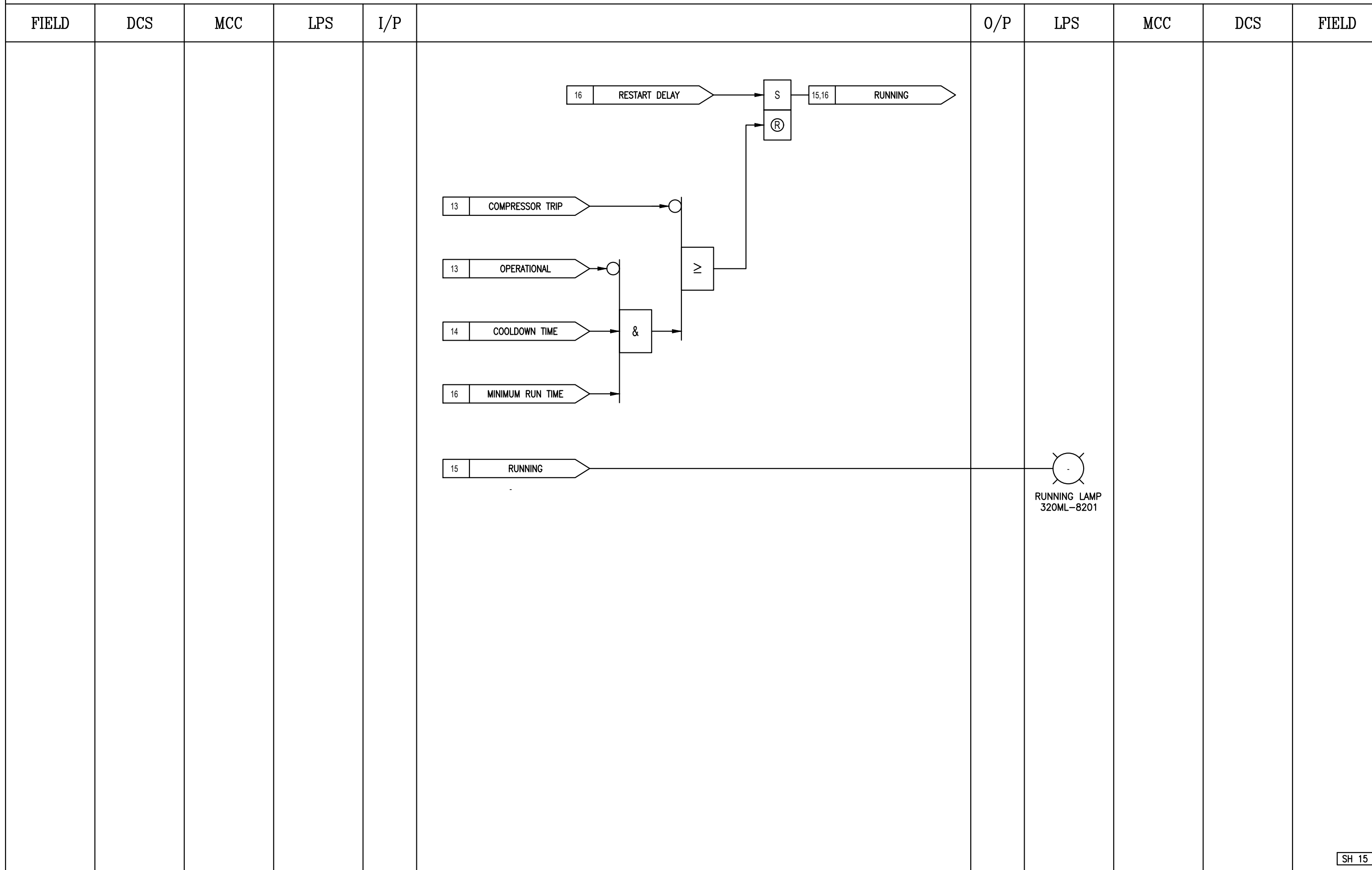

SH 15

NOTES:

1. -



SUBJECT		LOGIC DIAGRAM HIGH PRESSURE AIR COMPRESSOR K020	
CLIENT	Lavan Industry Development Company	PLANT LOCATION	IRAN, ONSHORE
CLIENT REF	N-278-VD-6019-EL-DIA-0049	DRAWING NO.	17735-32
AIRPACK REF	17735-COM	SHEET NO.	15 / 17

DATE	08-03-2024
DRAWN BY	AZ
CHECKED BY	SK

THIS DRAWING IS OWNED BY AIRPACK AND SHALL NOT BE PRINTED OR COPIED IN ANY OTHER WAY THAN WITH AIRPACKS PERMISSION

03	01-05-2024	AZ
02	09-04-2024	AZ
01	08-03-2024	AZ

LOGIC DIAGRAM

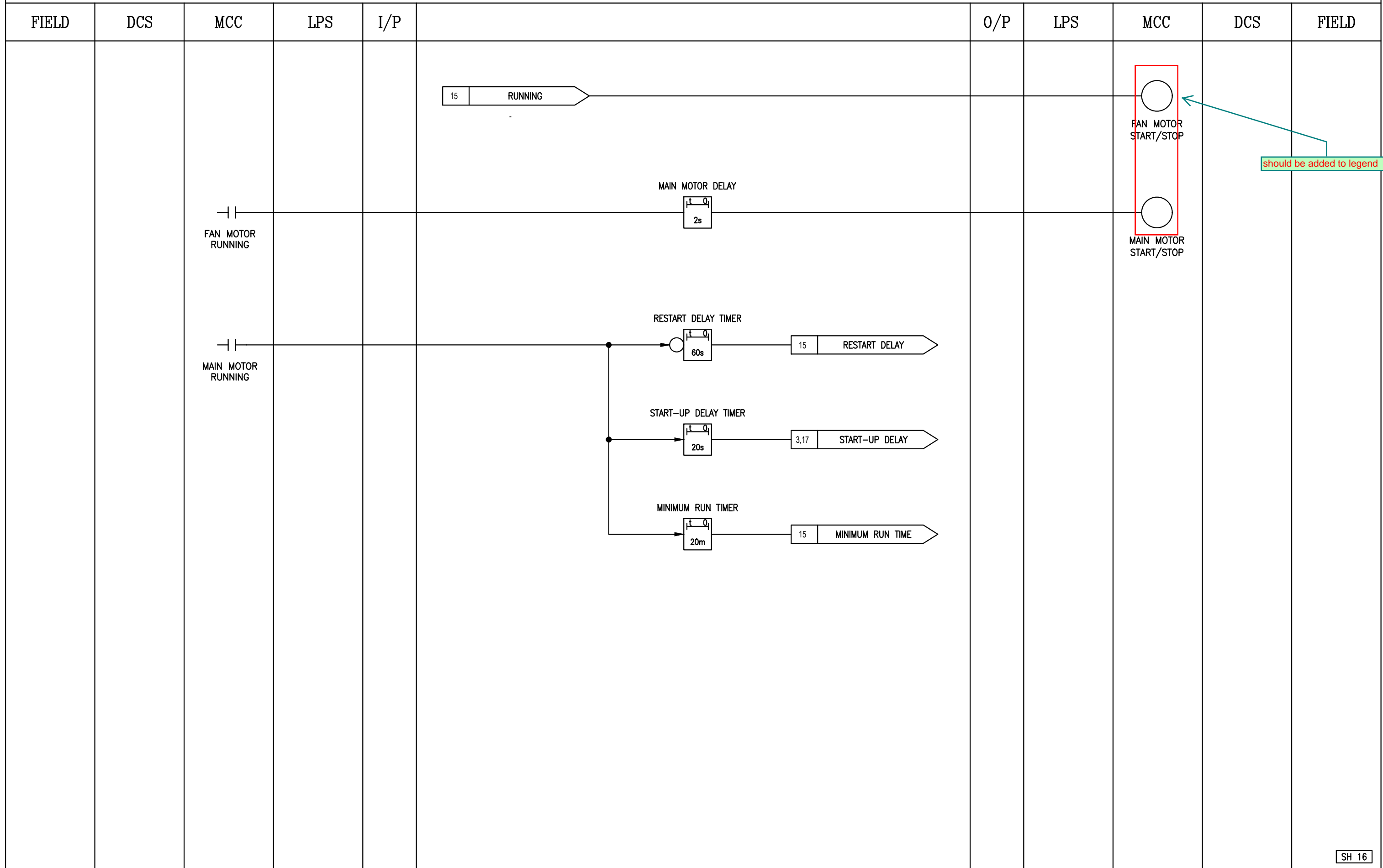

should be added to legend

NOTES:

1. -



SUBJECT		LOGIC DIAGRAM HIGH PRESSURE AIR COMPRESSOR K020	
CLIENT	Lavan Industry Development Company	DATE	08-03-2024
CLIENT REF	N-278-VD-6019-EL-DIA-0049	DRAWN BY	AZ
AIRPACK REF	17735-COM	CHECKED BY	SK
		PLANT LOCATION	IRAN, ONSHORE
		DRAWING NO.	17735-32
		SHEET NO.	16 / 17

THIS DRAWING IS OWNED BY AIRPACK AND SHALL NOT BE PRINTED OR COPIED IN ANY OTHER WAY THAN WITH AIRPACKS PERMISSION		
03	01-05-2024	AZ
02	09-04-2024	AZ
01	08-03-2024	AZ

LOGIC DIAGRAM

FIELD	DCS	MCC	LPS	I/P		O/P	LPS	MCC	DCS	FIELD
					Positioner feedback signal (PZT-8201) should be implemented in this page.					
					whereas positioner feedback signal is an Analog signal, tag name PZLC-8201 (PZLC is used for limit switch and digital signal) should be modified to PZT-8201 in PID and relevant document. PZT-8201 is correct for analog input signal.					

NOTES:

1. -



SUBJECT		LOGIC DIAGRAM HIGH PRESSURE AIR COMPRESSOR K020		DATE	08-03-2024	THIS DRAWING IS OWNED BY AIRPACK AND SHALL NOT BE PRINTED OR COPIED IN ANY OTHER WAY THAN WITH AIRPACKS PERMISSION			
CLIENT		Lavan Industry Development Company		DRAWN BY	AZ				
CLIENT REF		N-278-VD-6019-EL-DIA-0049		CHECKED BY	SK				
AIRPACK REF		17735-COM		PLANT LOCATION	IRAN, ONSHORE				
				DRAWING NO.	17735-32		03	01-05-2024	AZ
				SHEET NO.	17 / 17		02	09-04-2024	AZ
							01	08-03-2024	AZ