

Control and shut down Logic Block Diagram

Document No. 17735-32

Project No.	Vendor Doc.	P.O. No.	Department	Document Type	Serial No	Revision	Page
N278	VD	6019	EL	DIA	0049	07	Page 1 of 19

**Airpack B.V. - Air Compressor –
Integrated Methanol and Ammonia Plant
17735-COM Control and shut down Logic Block Diagram (K020)**

Code 1
M.Dalakeh

07	27-08-2027	Issued for Approval	A.Z.	S.K.	J.J.
06	06-08-2024	Issued for Approval	A.Z.	S.K.	J.J.
05	18-07-2024	Issued for Approval	S.K.	S.K.	J.J.
05	18-07-2024	Issued for Approval	A.Z.	S.K.	J.J.
03	01-05-2024	Issued for Approval	A.Z.	S.K.	J.J.
02	09-04-2024	Issued for Approval	A.Z.	S.K.	J.J.
01	08-03-2024	Issued for Approval	A.Z.	S.K.	J.J.
REV.	DATE	DESCRIPTION	DRAWN	CHECKED	APPROVED

Control and shut down Logic Block Diagram

Document No. 17735-32

Project No.	Vendor Doc.	P.O. No.	Department	Document Type	Serial No	Revision	Page
N278	VD	6019	EL	DIA	0049	07	Page 2 of 19

LIST OF REVISED PAGES

Rev. Page	01	02	03	04	05	06	07	08	09	10	Rev. Page	01	02	03	04	05	Rev. Page	01	02	03	04	05
1	X	X	X	X	X	X	X				51						76					
2	X	X	X	X	X	X	X				52						77					
3	X	X	X	X	X	X	X				53						78					
4	X	X	X	X	X	X	X				54						79					
5	X	X	X	X	X	X	X				55						80					
6	X	X	X	X	X	X	X				56						81					
7	X	X	X	X	X	X	X				57						82					
8	X	X	X	X	X	X	X				58						83					
9	X	X	X	X	X	X	X				59						84					
10	X	X	X	X	X	X	X				60						85					
11	X	X	X	X	X	X	X				61						86					
12	X	X	X	X	X	X	X				62						87					
13	X	X	X	X	X	X	X				63						88					
14	X	X	X	X	X	X	X				64						89					
15	X	X	X	X	X	X	X				65						90					
16	X	X	X	X	X	X	X				66						91					
17	X	X	X	X	X	X	X				67						92					
18	X	X	X	X	X	X	X				68						ATTACHMENT					
19	X	X	X	X	X	X	X				69						1					
20	X										70						2					
21											71						3					
22											72						4					
23											73						5					
24											74						6					
25											75						7					

SYMBOL	FUNCTION	DESCRIPTION
	AND	OUTPUT D EXISTS ONLY IF AND WHILE INPUTS A,B AND C EXIST.
	OR	OUTPUT D EXISTS ONLY IF AND WHILE ONE OR MORE OF INPUTS A,B OR C EXIST.
	XOR	OUTPUT D EXISTS ONLY IF AND WHILE ONE OF INPUTS A,B OR C EXIST.
	NOT	OUTPUT B EXISTS ONLY IF AND WHILE INPUT A DOES NOT EXIST.
	COMPARE	COMPARE FUNCTION THAT COMPARES THE VALUES IN X AND Y, AND IF THE COMPARISON INDICATED BY "TYPE" IS TRUE, OUTPUT A EXISTS. VALID COMPARISONS ARE: GREATER THAN(>), LESS THAN(<), EQUAL TO(==), GREATER THAN OR EQUAL TO (>=) AND LESS THAN OR EQUAL TO (<=).
	MOVE	IF INPUT A EXISTS, THE VALUE X IS ASSIGNED TO THE VARIABLE AT THE OUTPUT Y. TYPE IS INCLUDED TO INDICATE THE TYPE OF VARIABLE. B TERMINATES IMMEDIATELY WHEN A TERMINATES.
	TIMER (DELAY INITIATION)	THE CONTINUOUS EXISTENCE OF INPUT A FOR TIME T CAUSES OUTPUT B TO EXIST WHEN THE TIME T EXPIRES. B TERMINATES IMMEDIATELY WHEN A TERMINATES.
	TIMER (DELAY TERMINATION)	THE EXISTENCE OF INPUT A CAUSES OUTPUT B TO EXIST IMMEDIATELY. B TERMINATES WHEN A HAS TERMINATED AND HAS NOT AGAIN EXISTED FOR TIME T.
	PULSE OUTPUT	THE EXISTENCE OF INPUT A CAUSES OUTPUT B TO EXIST IMMEDIATELY. B EXISTS FOR TIME T, REGARDLESS OF THE STATE OF A.
	FLIP-FLOP MEMORY (SET PRIORITY)	OUTPUT C EXISTS AS SOON AS A EXISTS. C CONTINUES TO EXIST, REGARDLESS OF THE SUBSEQUENT STATE OF A, UNTIL THE MEMORY IS RESET (I.E; TERMINATED BY B EXISTING) C REMAINS TERMINATED, REGARDLESS OF THE SUBSEQUENT STATE OF B, UNTIL A CAUSES THE MEMORY TO BE SET. IF A AND B EXIST SIMULTANEOUSLY, A OVERRIDES B.
	FLIP-FLOP MEMORY (RESET PRIORITY)	OUTPUT C EXISTS AS SOON AS A EXISTS. C CONTINUES TO EXIST, REGARDLESS OF THE SUBSEQUENT STATE OF A, UNTIL THE MEMORY IS RESET (I.E; TERMINATED BY B EXISTING) C REMAINS TERMINATED, REGARDLESS OF THE SUBSEQUENT STATE OF B, UNTIL A CAUSES THE MEMORY TO BE SET. IF A AND B EXIST SIMULTANEOUSLY, B OVERRIDES A.
	RISING TRIGGER	THE EXISTENCE OF INPUT A CAUSES OUTPUT B TO EXIST IMMEDIATELY, AND FALL AWAY ON THE NEXT INSTRUCTION CYCLE.
		LOGIC CONNECTION, BRANCH
		NO CONNECTION, JUMP
		MODBUS CONNECTION

SYMBOL	DESCRIPTION
	EMERGENCY PUSHBUTTON, RED HEAD, STAY PUT.
	TWO WAY SWITCH
	THREE WAY SWITCH
	PUSHBUTTON MOMENTARILY MAKE
	PUSHBUTTON MOMENTARILY BREAK
	CONTACT NORMALLY OPEN
	CONTACT NORMALLY CLOSED
	HARDWIRED INPUT/OUTPUT
	SOLENOID VALVE, 3-WAY
	DCS CONTROL SYSTEM
	PLC CONTROL SYSTEM
	DCS AUXILIARY CONSOLE
	LAMP
	HMI
	AUDIBLE ALARM
	RELAY COIL

GENERAL NOTES

- THIS LOGIC DIAGRAM PROVIDES THE DETAILED OPERATION OF COMPRESSOR K020.
- SHUTDOWN CONDITION ;
0 = SHUTDOWN 1 = OPERATING
- ALARM/TRIP CONDITION ;
0 = ALARM 1=NORMAL
0 = TRIP 1=NORMAL

ABBREVIATIONS

DCS : DISTRIBUTED CONTROL SYSTEM
MCC : MOTOR CONTROL CENTER
LPS : LOCAL PANEL STATION
I/P : HARDWIRED INPUT
O/P : HARDWIRED OUTPUT

DEFINITION

- AVAILABLE: COMPRESSOR READY TO START.
- RUNNING: PACKAGE RUNNING.
- LOGIC CONTINUATION FROM/TO OTHER SHEET

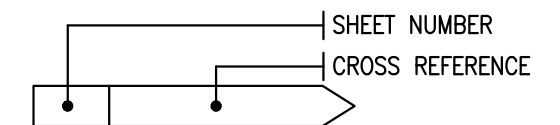

REFERENCE DOCUMENTS

- Piping & Instrument Diagram
- Cause & Effect Chart
- Control philosophy and Interlock Description
- I/O List

SH 1



SUBJECT	LOGIC DIAGRAM	DATE	08-03-2024	THIS DRAWING IS OWNED BY AIRPACK AND SHALL NOT BE PRINTED OR COPIED IN ANY OTHER WAY THAN WITH AIRPACKS PERMISSION	07	19-08-2024	AZ
	HIGH PRESSURE AIR COMPRESSOR K020	DRAWN BY	AZ		06	06-08-2024	SK
CLIENT	Lavan Industry Development Company	CHECKED BY	SK	05	18-07-2024	AZ	
	N-278-VD-6019-EL-DIA-0049	PLANT LOCATION	IRAN, ONSHORE	04	04-07-2024	AZ	
AIRPACK REF	17735-COM	DRAWING NO.	17735-32	03	01-05-2024	AZ	
		SHEET NO.	01 / 17	02	09-04-2024	AZ	
				01	08-03-2024	AZ	

LOGIC DIAGRAM

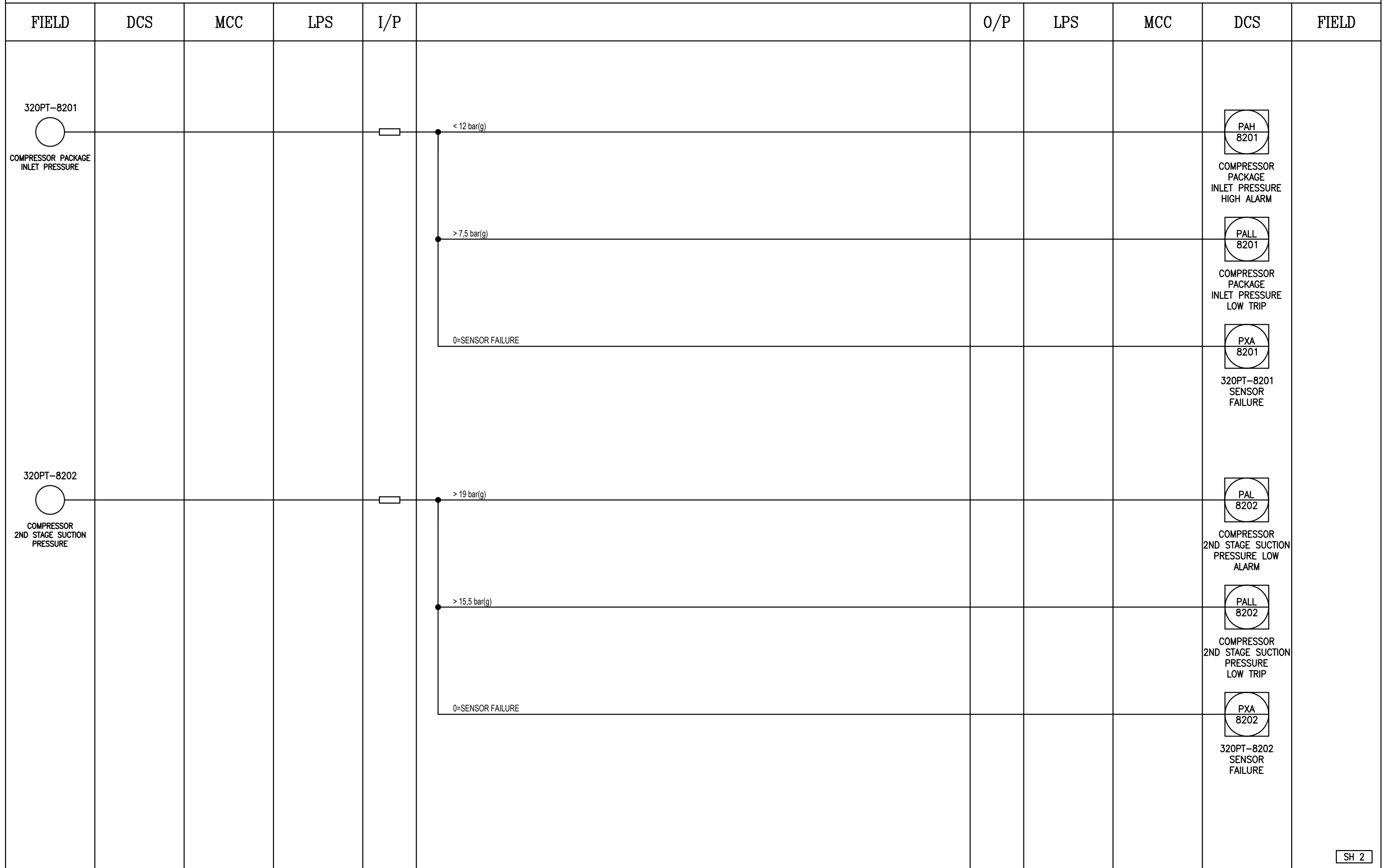

SH 2

NOTES:

1. -



SUBJECT		LOGIC DIAGRAM		DATE	08-03-2024
		HIGH PRESSURE AIR COMPRESSOR K020		DRAWN BY	AZ
				CHECKED BY	SK
CLIENT	Lavan Industry Development Company			PLANT LOCATION	IRAN, ONSHORE
CLIENT REF	N-278-VD-6019-EL-DIA-0049			DRAWING NO.	17735-32
AIRPACK REF	17735-COM			SHEET NO.	02 / 17

THIS DRAWING IS OWNED BY AIRPACK AND SHALL NOT BE PRINTED OR COPIED IN ANY OTHER WAY THAN WITH AIRPACKS PERMISSION

07	19-08-2024	AZ
06	06-08-2024	SK
05	18-07-2024	AZ
04	04-07-2024	AZ
03	01-05-2024	AZ
02	09-04-2024	AZ
01	08-03-2024	AZ

LOGIC DIAGRAM

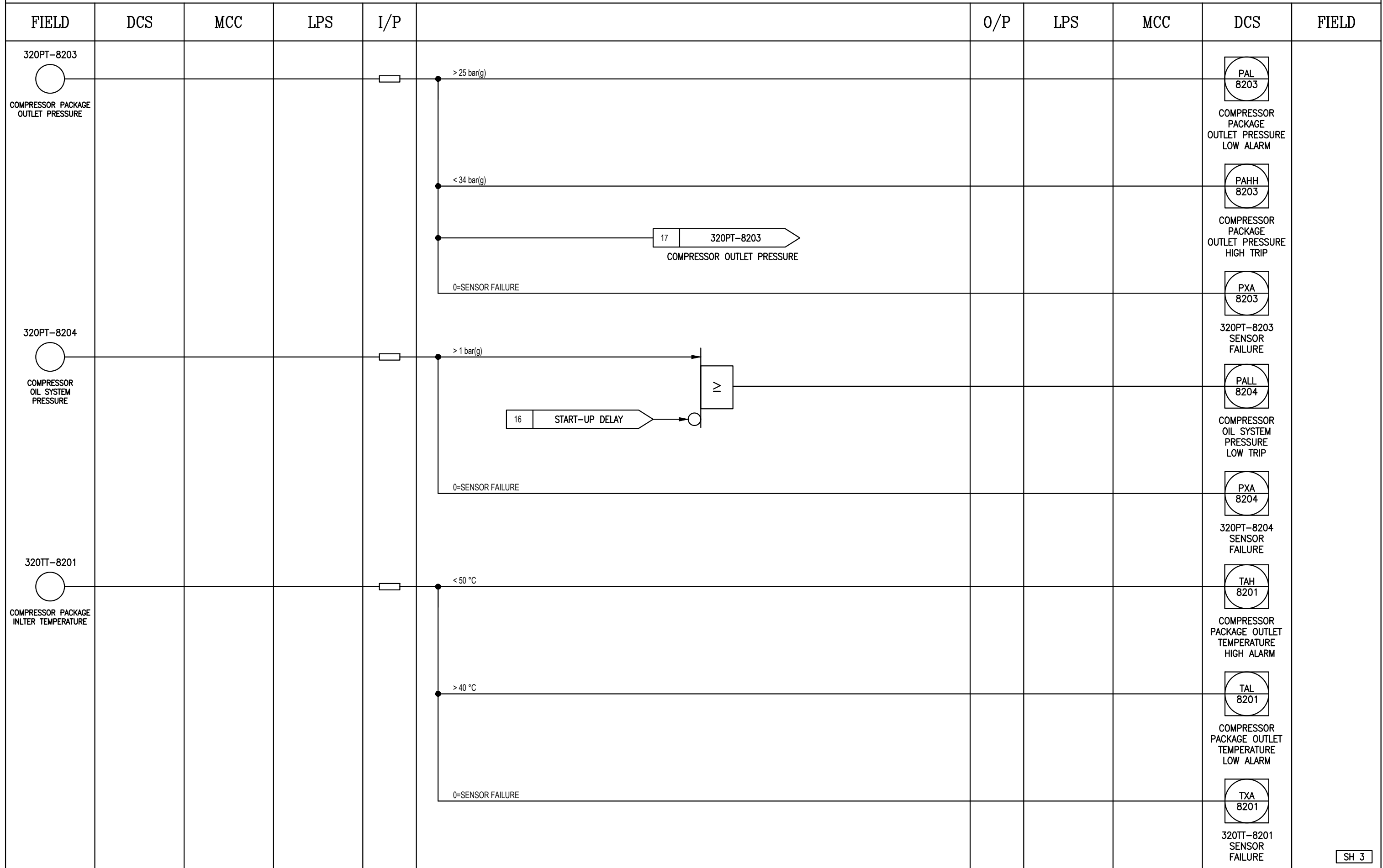

SH 3

NOTES:

1. -



SUBJECT		LOGIC DIAGRAM HIGH PRESSURE AIR COMPRESSOR K020		DATE	08-03-2024
CLIENT		Lavan Industry Development Company		DRAWN BY	AZ
CLIENT REF		N-278-VD-6019-EL-DIA-0049		CHECKED BY	SK
AIRPACK REF		17735-COM		PLANT LOCATION	IRAN, ONSHORE
				DRAWING NO.	17735-32
				SHEET NO.	03 / 17

THIS DRAWING IS OWNED BY AIRPACK AND SHALL NOT BE PRINTED OR COPIED IN ANY OTHER WAY THAN WITH AIRPACKS PERMISSION

07	19-08-2024	AZ
06	06-08-2024	SK
05	18-07-2024	AZ
04	04-07-2024	AZ
03	01-05-2024	AZ
02	09-04-2024	AZ
01	08-03-2024	AZ

LOGIC DIAGRAM

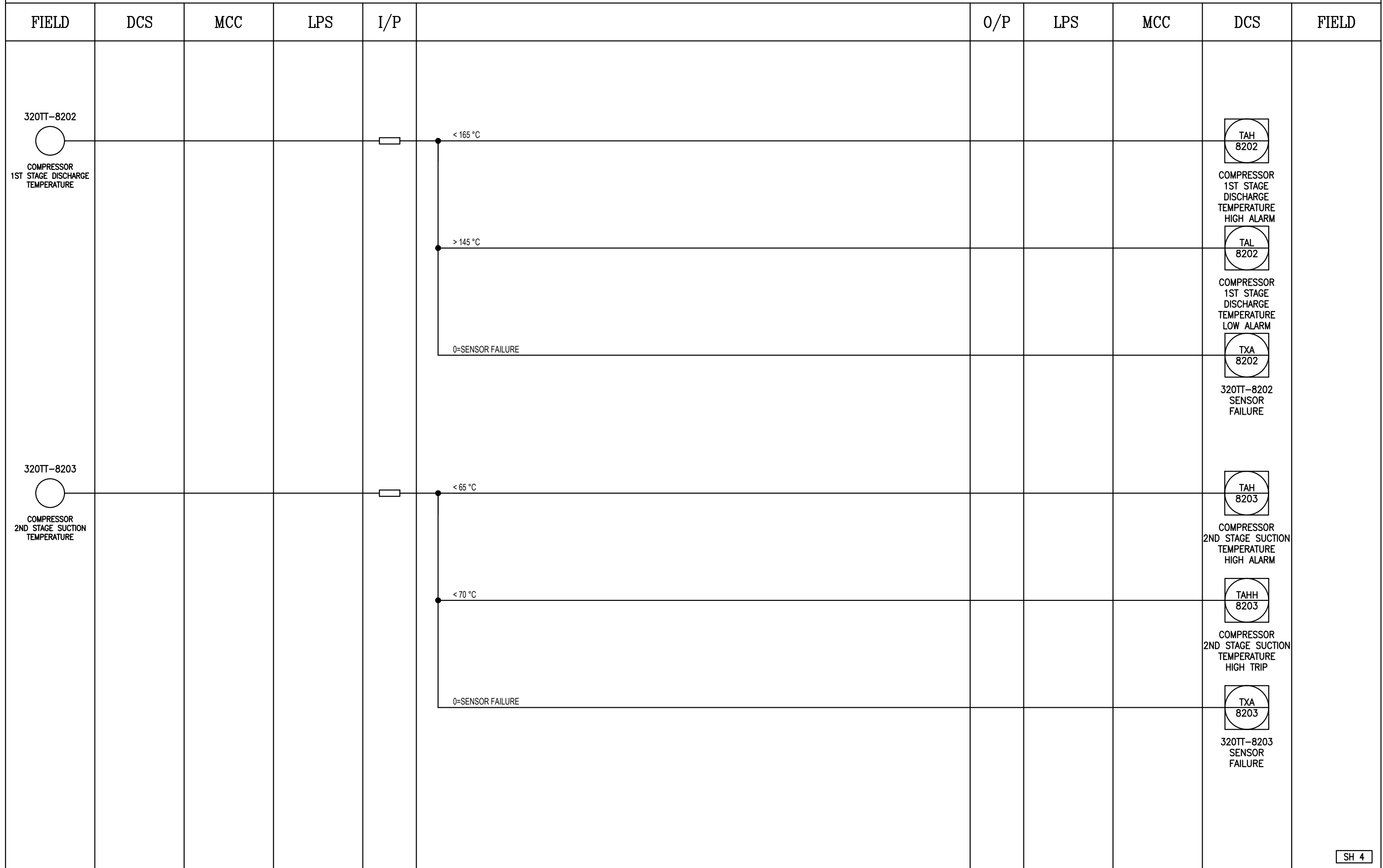

SH 4

NOTES:

1. -



SUBJECT		LOGIC DIAGRAM		DATE	08-03-2024
		HIGH PRESSURE AIR COMPRESSOR K020		DRAWN BY	AZ
				CHECKED BY	SK
CLIENT	Lavan Industry Development Company	PLANT LOCATION	IRAN, ONSHORE	THIS DRAWING IS OWNED BY AIRPACK AND SHALL NOT BE PRINTED OR COPIED IN ANY OTHER WAY THAN WITH AIRPACKS PERMISSION	
CLIENT REF	N-278-VD-6019-EL-DIA-0049	DRAWING NO.	17735-32	07	19-08-2024
AIRPACK REF	17735-COM	SHEET NO.	04 / 17	06	06-08-2024
				05	18-07-2024
				04	04-07-2024
				03	01-05-2024
				02	09-04-2024
				01	08-03-2024
				AZ	
				SK	
				AZ	
				AZ	
				AZ	
				AZ	

LOGIC DIAGRAM

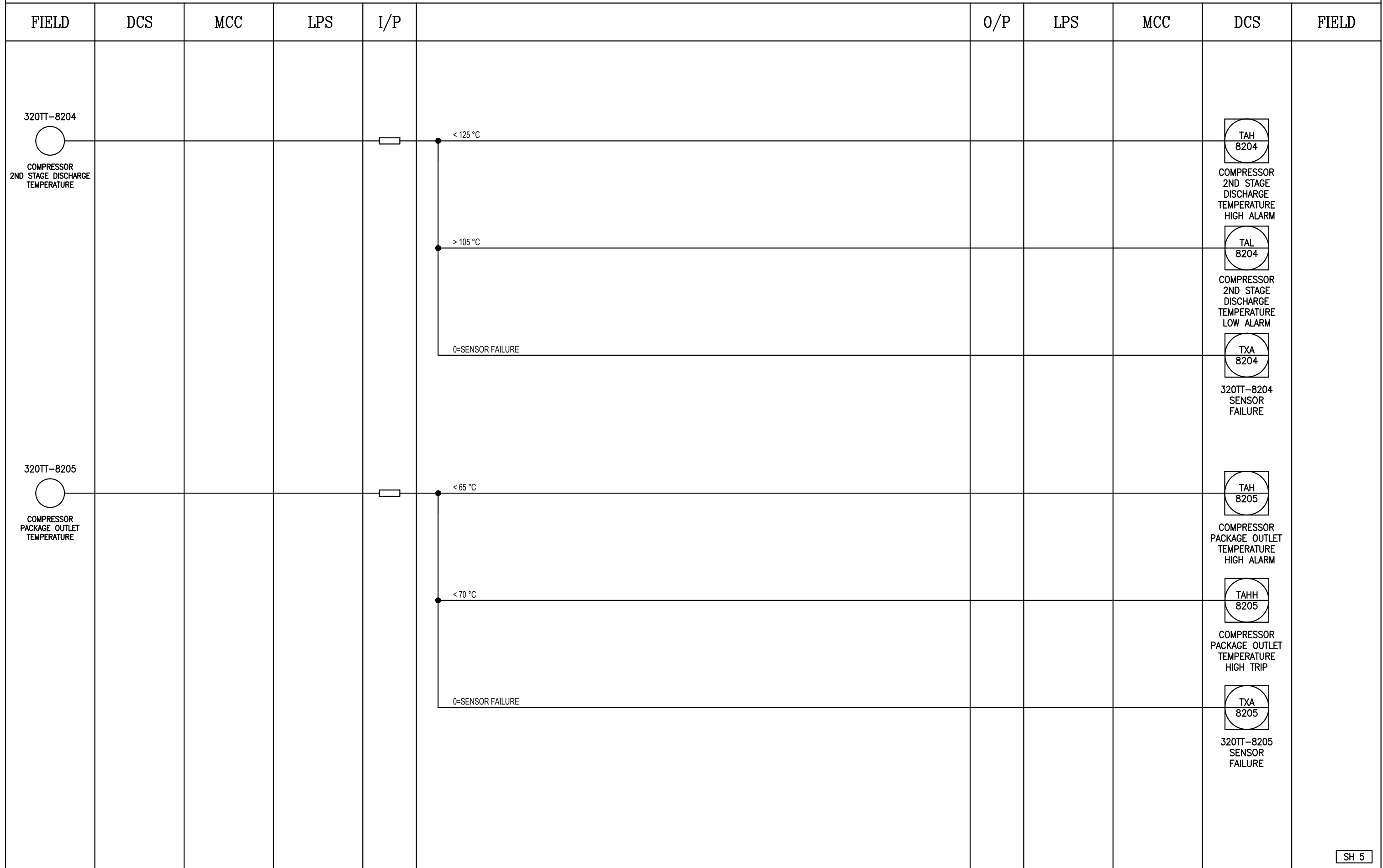

SH 5

NOTES:

1. -



SUBJECT		LOGIC DIAGRAM		DATE	08-03-2024
		HIGH PRESSURE AIR COMPRESSOR K020		DRAWN BY	AZ
				CHECKED BY	SK
CLIENT	Lavan Industry Development Company	PLANT LOCATION	IRAN, ONSHORE	THIS DRAWING IS OWNED BY AIRPACK AND SHALL NOT BE PRINTED OR COPIED IN ANY OTHER WAY THAN WITH AIRPACKS PERMISSION	
CLIENT REF	N-278-VD-6019-EL-DIA-0049	DRAWING NO.	17735-32		
AIRPACK REF	17735-COM	SHEET NO.	05 / 17		

07	19-08-2024	AZ
06	06-08-2024	SK
05	18-07-2024	AZ
04	04-07-2024	AZ
03	01-05-2024	AZ
02	09-04-2024	AZ
01	08-03-2024	AZ

LOGIC DIAGRAM

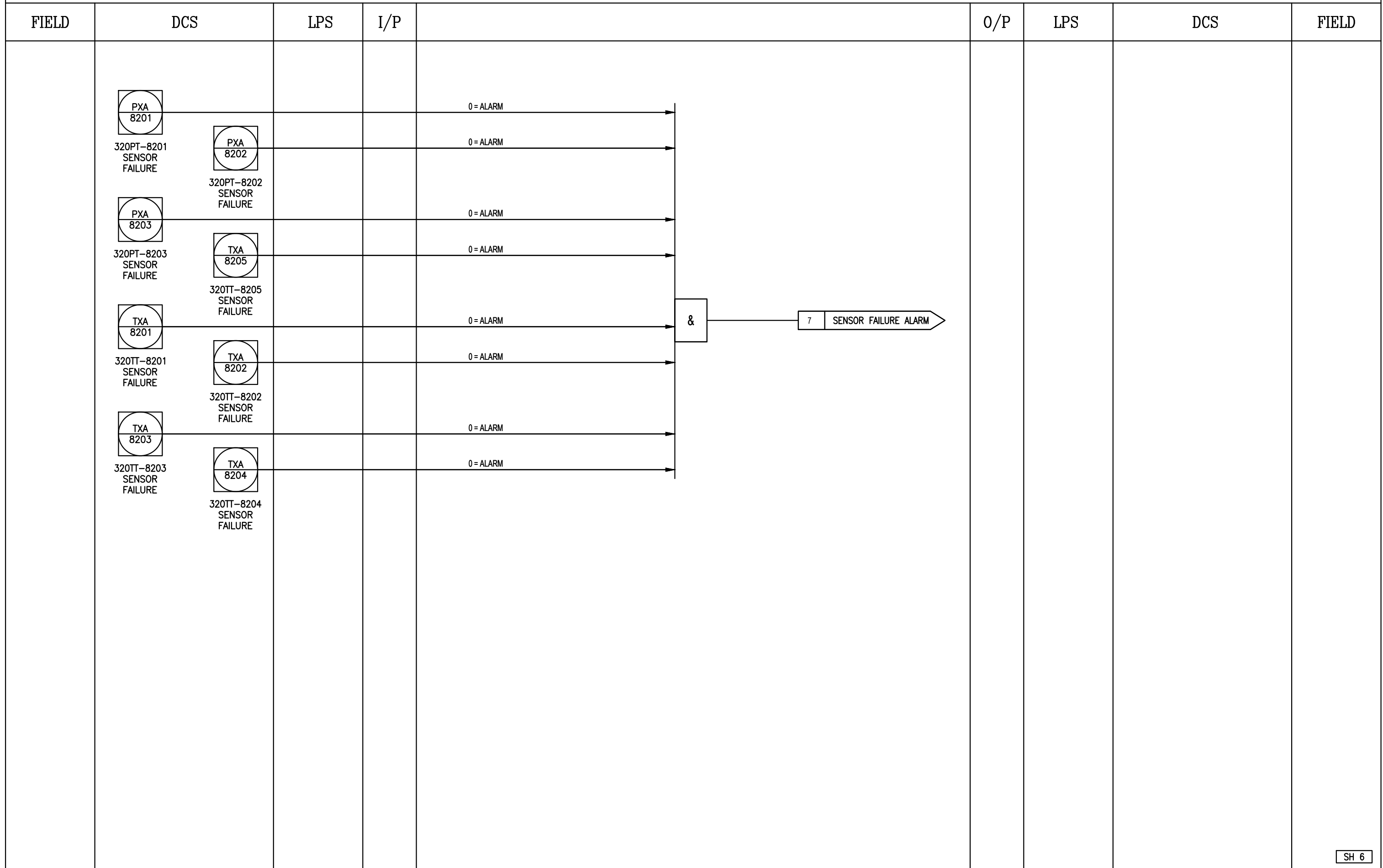

SH 6

NOTES:

1. -



SUBJECT		LOGIC DIAGRAM		DATE	08-03-2024
		HIGH PRESSURE AIR COMPRESSOR		DRAWN BY	AZ
		K020		CHECKED BY	SK
CLIENT	Lavan Industry Development Company		PLANT LOCATION	IRAN, ONSHORE	
CLIENT REF	N-278-VD-6019-EL-DIA-0049		DRAWING NO.	17735-32	
AIRPACK REF	17735-COM		SHEET NO.	06 / 17	

THIS DRAWING IS OWNED BY AIRPACK AND SHALL NOT BE PRINTED OR COPIED IN ANY OTHER WAY THAN WITH AIRPACKS PERMISSION

07	19-08-2024	AZ
06	06-08-2024	SK
05	18-07-2024	AZ
04	04-07-2024	AZ
03	01-05-2024	AZ
02	09-04-2024	AZ
01	08-03-2024	AZ

LOGIC DIAGRAM

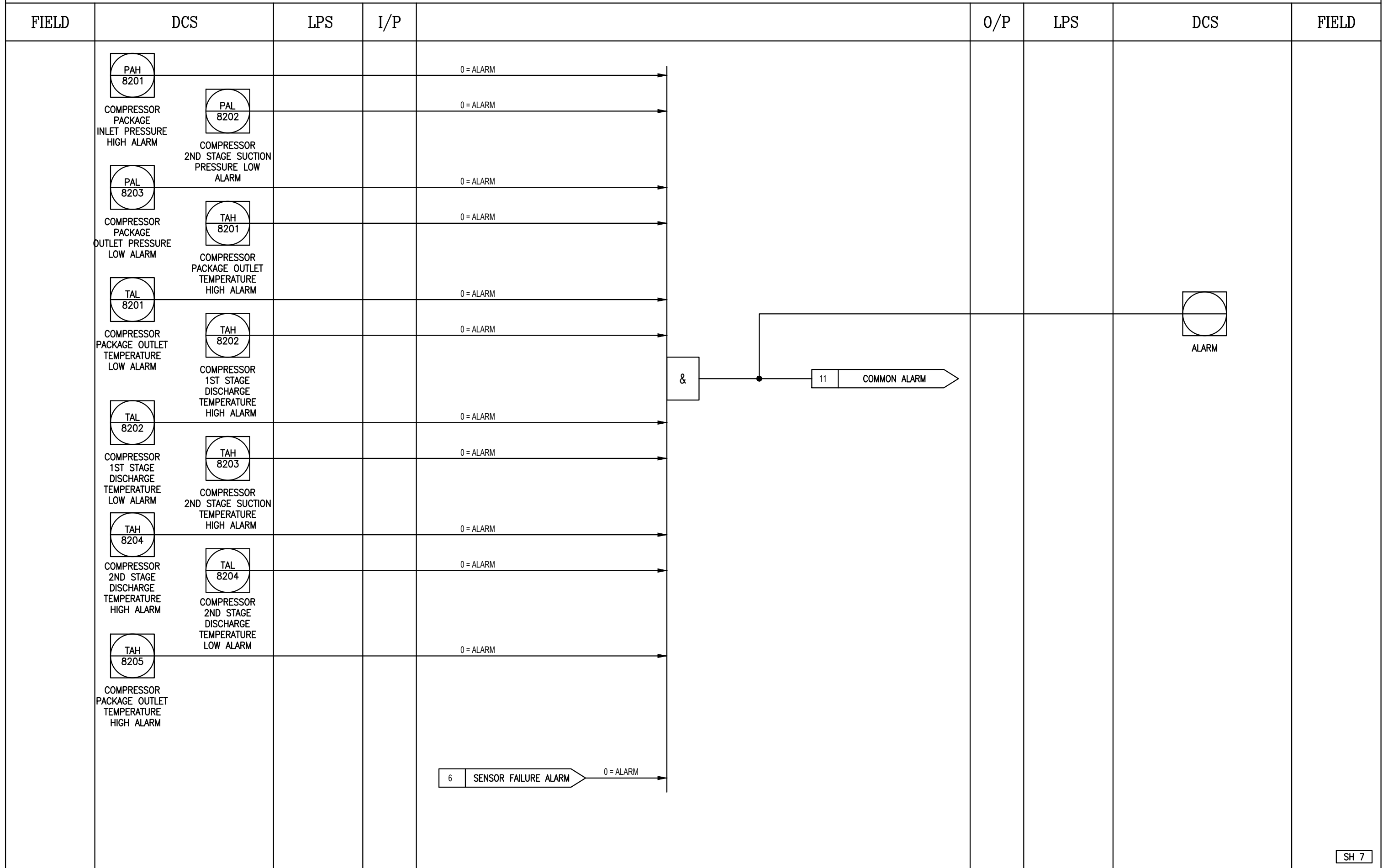

SH 7

NOTES:

1. -



SUBJECT		LOGIC DIAGRAM		DATE	08-03-2024	THIS DRAWING IS OWNED BY AIRPACK AND SHALL NOT BE PRINTED OR COPIED IN ANY OTHER WAY THAN WITH AIRPACKS PERMISSION	07	19-08-2024	AZ
		HIGH PRESSURE AIR COMPRESSOR K020		DRAWN BY	AZ		06	06-08-2024	SK
				CHECKED BY	SK		05	18-07-2024	AZ
CLIENT	Lavan Industry Development Company			PLANT LOCATION	IRAN, ONSHORE		04	04-07-2024	AZ
CLIENT REF	N-278-VD-6019-EL-DIA-0049			DRAWING NO.	17735-32	03	01-05-2024	AZ	
AIRPACK REF	17735-COM			SHEET NO.	07 / 17	02	09-04-2024	AZ	
						01	08-03-2024	AZ	

LOGIC DIAGRAM

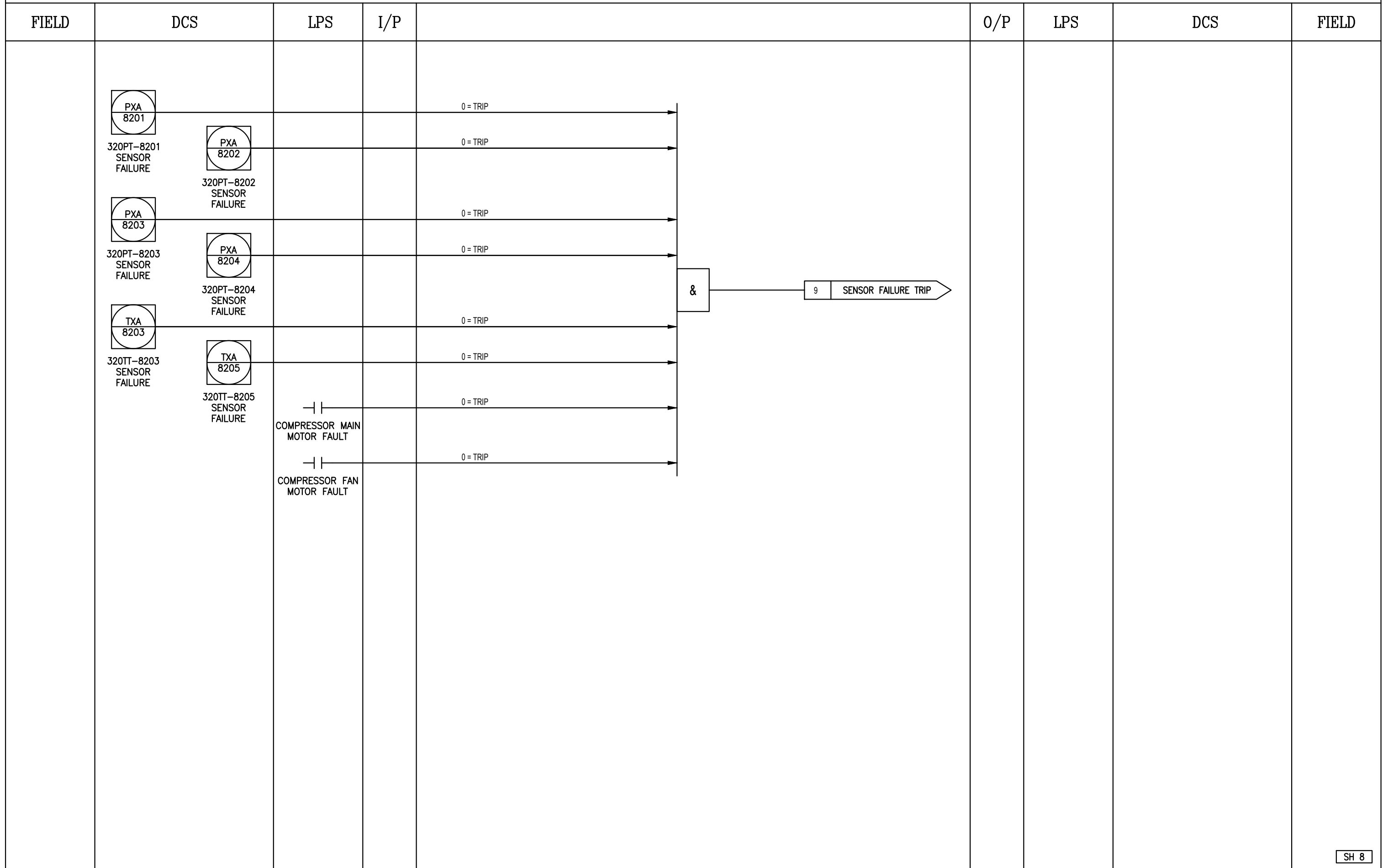

SH 8

NOTES:

1. -



SUBJECT		LOGIC DIAGRAM HIGH PRESSURE AIR COMPRESSOR K020		DATE	08-03-2024	THIS DRAWING IS OWNED BY AIRPACK AND SHALL NOT BE PRINTED OR COPIED IN ANY OTHER WAY THAN WITH AIRPACKS PERMISSION	07	19-08-2024	AZ
CLIENT		Lavan Industry Development Company		DRAWN BY	AZ		06	06-08-2024	SK
CLIENT REF		N-278-VD-6019-EL-DIA-0049		CHECKED BY	SK		05	18-07-2024	AZ
AIRPACK REF		17735-COM		PLANT LOCATION	IRAN, ONSHORE		04	04-07-2024	AZ
				DRAWING NO.	17735-32	03	01-05-2024	AZ	
				SHEET NO.	08 / 17	02	09-04-2024	AZ	
						01	08-03-2024	AZ	

LOGIC DIAGRAM

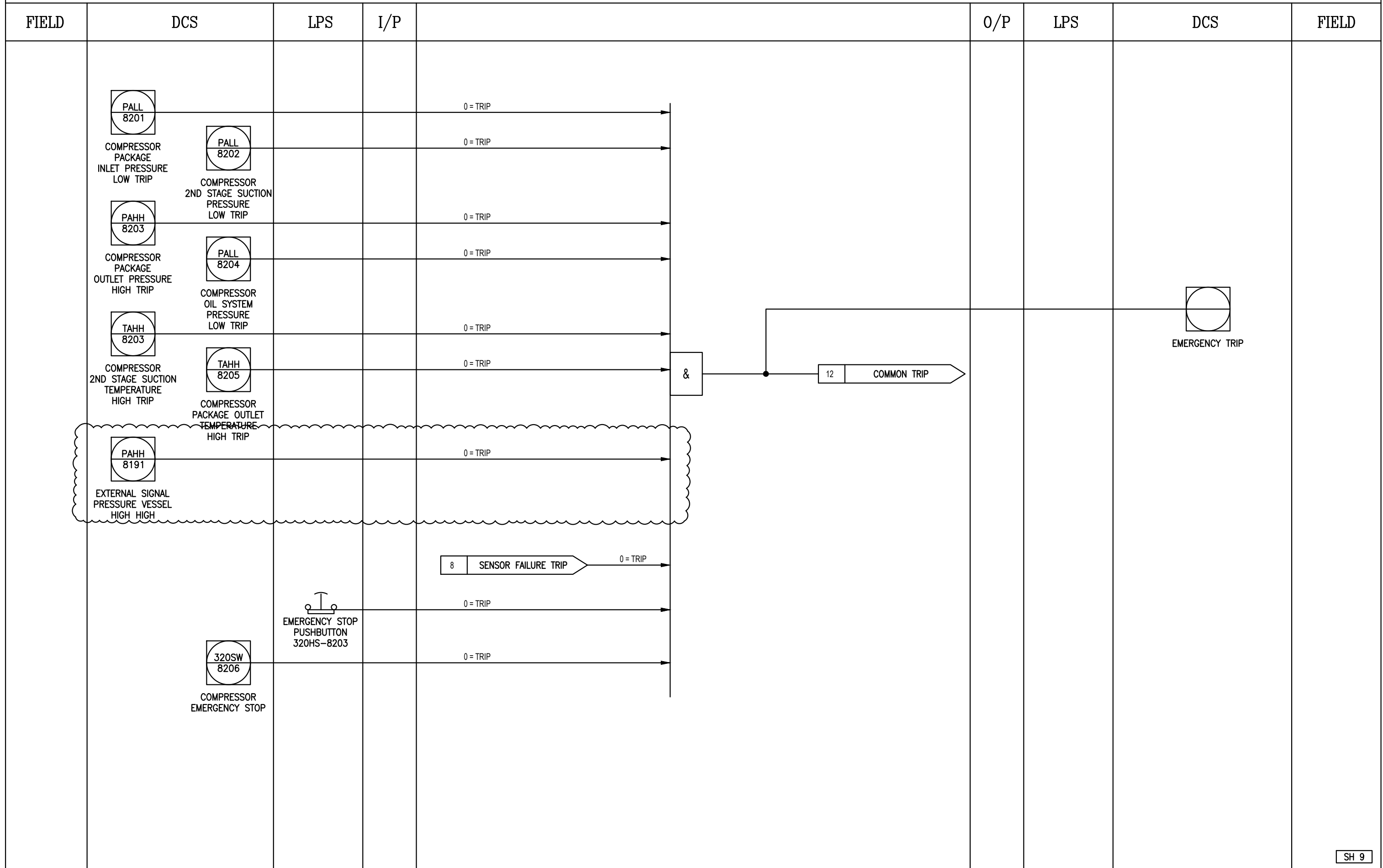

SH 9

NOTES:

1. -



SUBJECT		LOGIC DIAGRAM HIGH PRESSURE AIR COMPRESSOR K020		DATE	08-03-2024	THIS DRAWING IS OWNED BY AIRPACK AND SHALL NOT BE PRINTED OR COPIED IN ANY OTHER WAY THAN WITH AIRPACKS PERMISSION	07	19-08-2024	AZ
DRAWN BY		AZ		CHECKED BY	SK		06	06-08-2024	SK
CLIENT	Lavan Industry Development Company			PLANT LOCATION	IRAN, ONSHORE		05	18-07-2024	AZ
CLIENT REF	N-278-VD-6019-EL-DIA-0049			DRAWING NO.	17735-32		04	04-07-2024	AZ
AIRPACK REF	17735-COM			SHEET NO.	09 / 17	03	01-05-2024	AZ	
						02	09-04-2024	AZ	
						01	08-03-2024	AZ	

LOGIC DIAGRAM

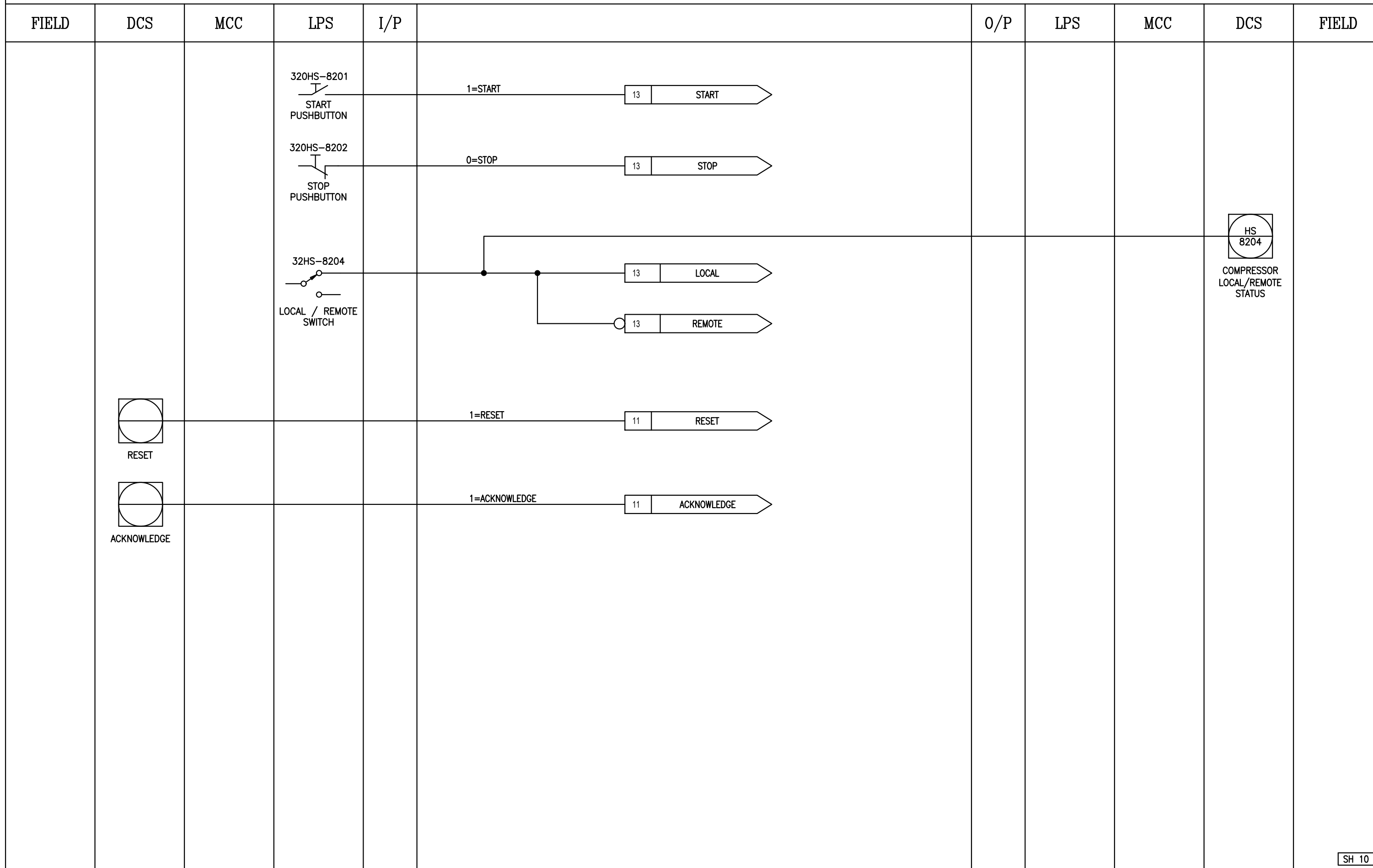

SH 10

NOTES:

1. -



SUBJECT		LOGIC DIAGRAM HIGH PRESSURE AIR COMPRESSOR K020	
CLIENT	Lavan Industry Development Company	PLANT LOCATION	IRAN, ONSHORE
CLIENT REF	N-278-VD-6019-EL-DIA-0049	DRAWING NO.	17735-32
AIRPACK REF	17735-COM	SHEET NO.	10 / 17

DATE	08-03-2024
DRAWN BY	AZ
CHECKED BY	SK

THIS DRAWING IS OWNED BY AIRPACK AND SHALL NOT BE PRINTED OR COPIED IN ANY OTHER WAY THAN WITH AIRPACKS PERMISSION

07	19-08-2024	AZ
06	06-08-2024	SK
05	18-07-2024	AZ
04	04-07-2024	AZ
03	01-05-2024	AZ
02	09-04-2024	AZ
01	08-03-2024	AZ

LOGIC DIAGRAM

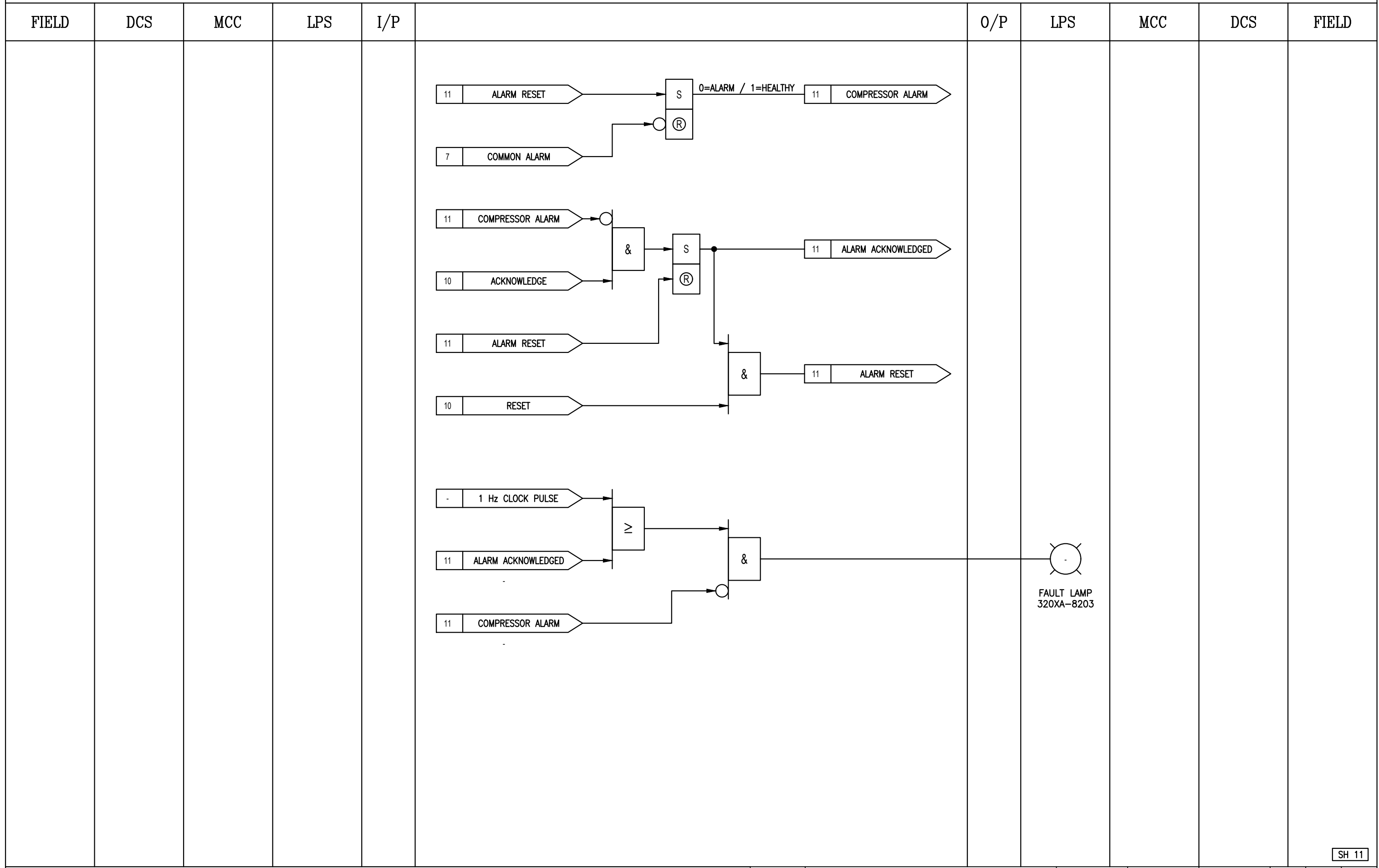

SH 11

NOTES:

1. -



SUBJECT LOGIC DIAGRAM HIGH PRESSURE AIR COMPRESSOR K020		DATE	08-03-2024	THIS DRAWING IS OWNED BY AIRPACK AND SHALL NOT BE PRINTED OR COPIED IN ANY OTHER WAY THAN WITH AIRPACKS PERMISSION	07	19-08-2024	AZ
		DRAWN BY	AZ		06	06-08-2024	SK
CHECKED BY	SK	05	18-07-2024		AZ		
CLIENT	Lavan Industry Development Company	PLANT LOCATION	IRAN, ONSHORE		04	04-07-2024	AZ
CLIENT REF	N-278-VD-6019-EL-DIA-0049	DRAWING NO.	17735-32		03	01-05-2024	AZ
AIRPACK REF	17735-COM	SHEET NO.	11 / 17		02	09-04-2024	AZ
					01	08-03-2024	AZ

LOGIC DIAGRAM

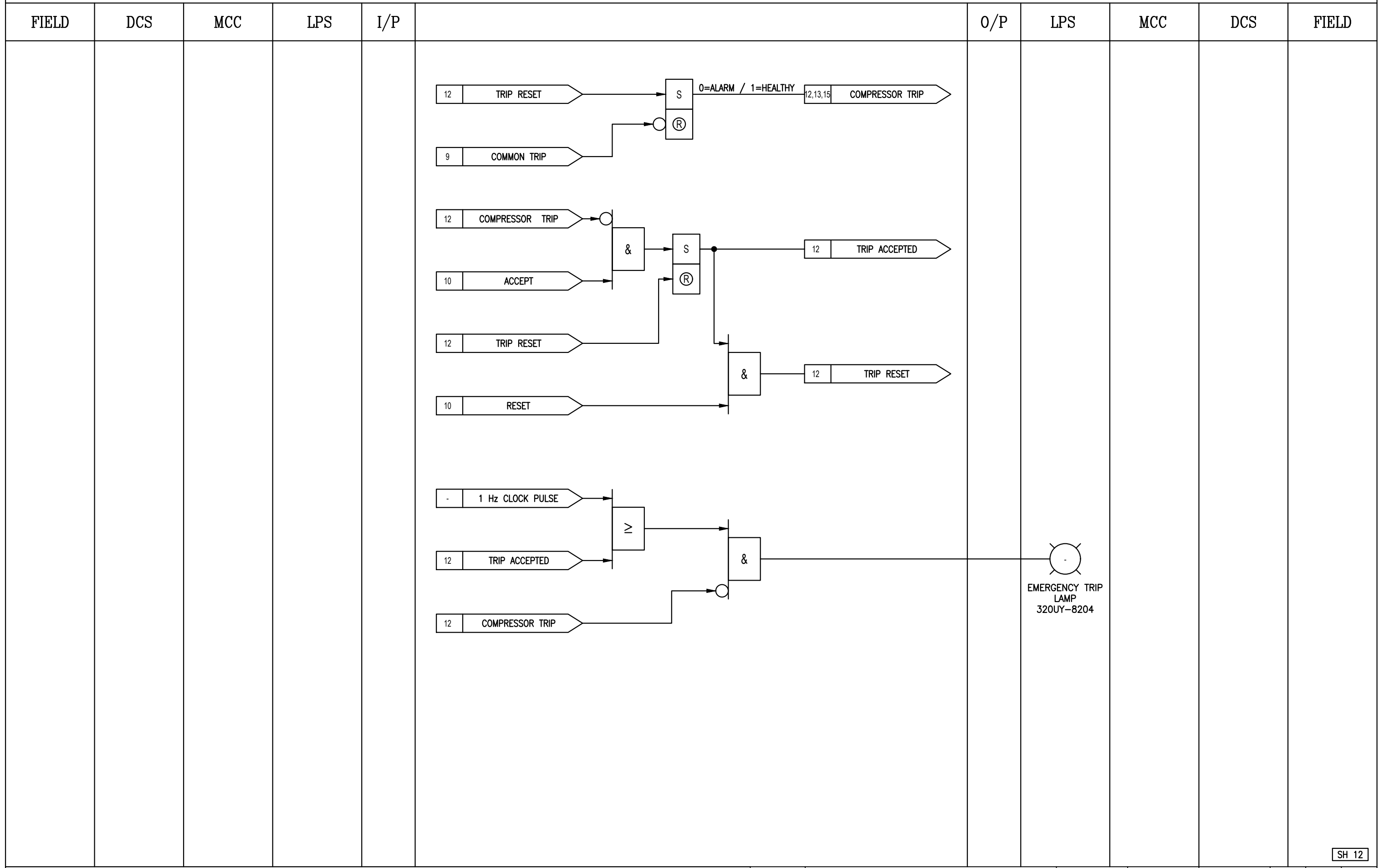

SH 12

NOTES:

1. -



SUBJECT LOGIC DIAGRAM HIGH PRESSURE AIR COMPRESSOR K020		DATE	08-03-2024	THIS DRAWING IS OWNED BY AIRPACK AND SHALL NOT BE PRINTED OR COPIED IN ANY OTHER WAY THAN WITH AIRPACKS PERMISSION	07	19-08-2024	AZ
		DRAWN BY	AZ		06	06-08-2024	SK
CHECKED BY	SK	05	18-07-2024		AZ		
CLIENT	Lavan Industry Development Company	PLANT LOCATION	IRAN, ONSHORE		04	04-07-2024	AZ
CLIENT REF	N-278-VD-6019-EL-DIA-0049	DRAWING NO.	17735-32		03	01-05-2024	AZ
AIRPACK REF	17735-COM	SHEET NO.	12 / 17		02	09-04-2024	AZ
					01	08-03-2024	AZ

LOGIC DIAGRAM

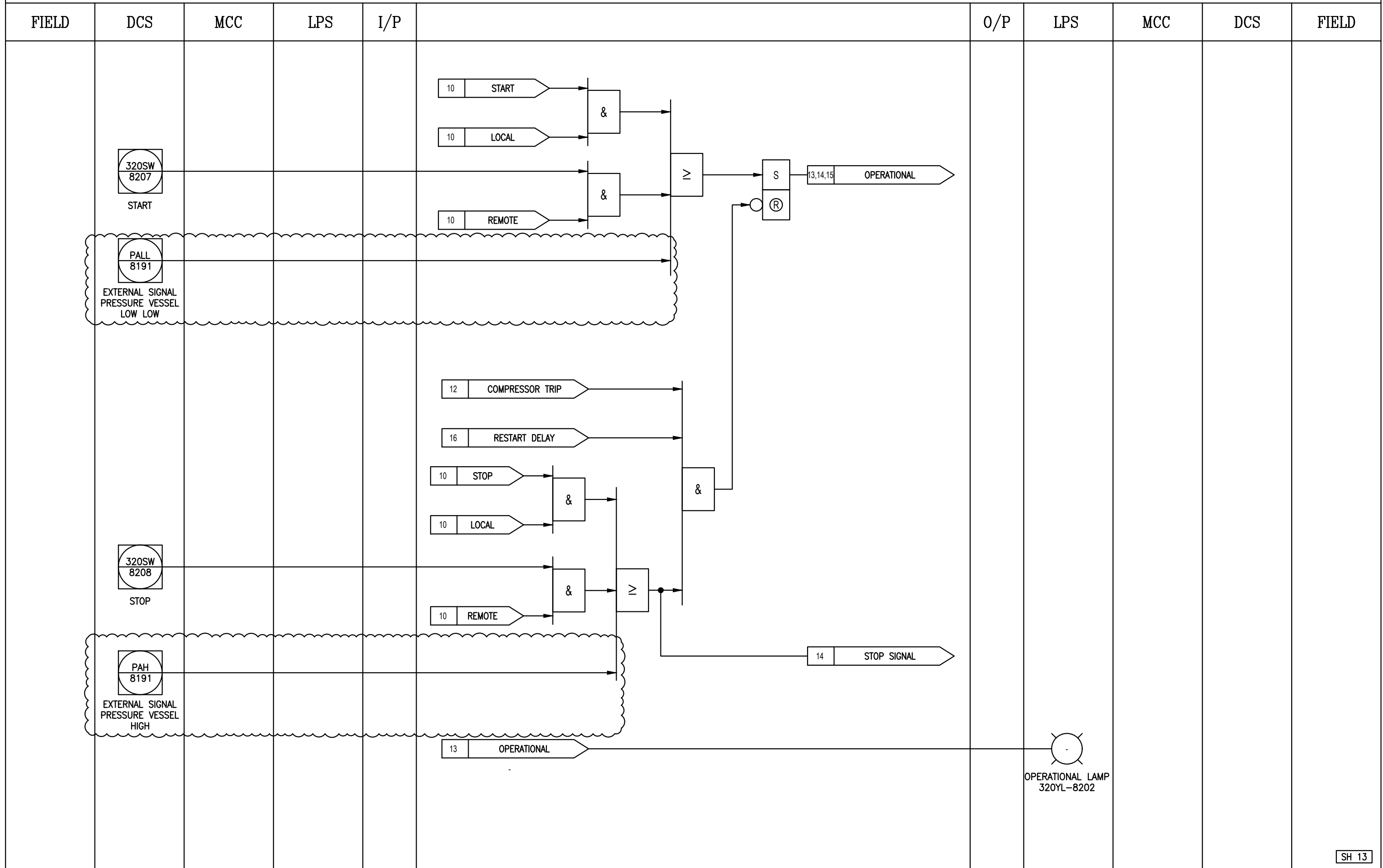

SH 13

NOTES:

1. -



SUBJECT		LOGIC DIAGRAM HIGH PRESSURE AIR COMPRESSOR K020	
CLIENT	Lavan Industry Development Company	DATE	08-03-2024
CLIENT REF	N-278-VD-6019-EL-DIA-0049	DRAWN BY	AZ
AIRPACK REF	17735-COM	CHECKED BY	SK
		PLANT LOCATION	IRAN, ONSHORE
		DRAWING NO.	17735-32
		SHEET NO.	13 / 17

THIS DRAWING IS OWNED BY AIRPACK AND SHALL NOT BE PRINTED OR COPIED IN ANY OTHER WAY THAN WITH AIRPACKS PERMISSION	
07	19-08-2024 AZ
06	06-08-2024 SK
05	18-07-2024 AZ
04	04-07-2024 AZ
03	01-05-2024 AZ
02	09-04-2024 AZ
01	08-03-2024 AZ

LOGIC DIAGRAM

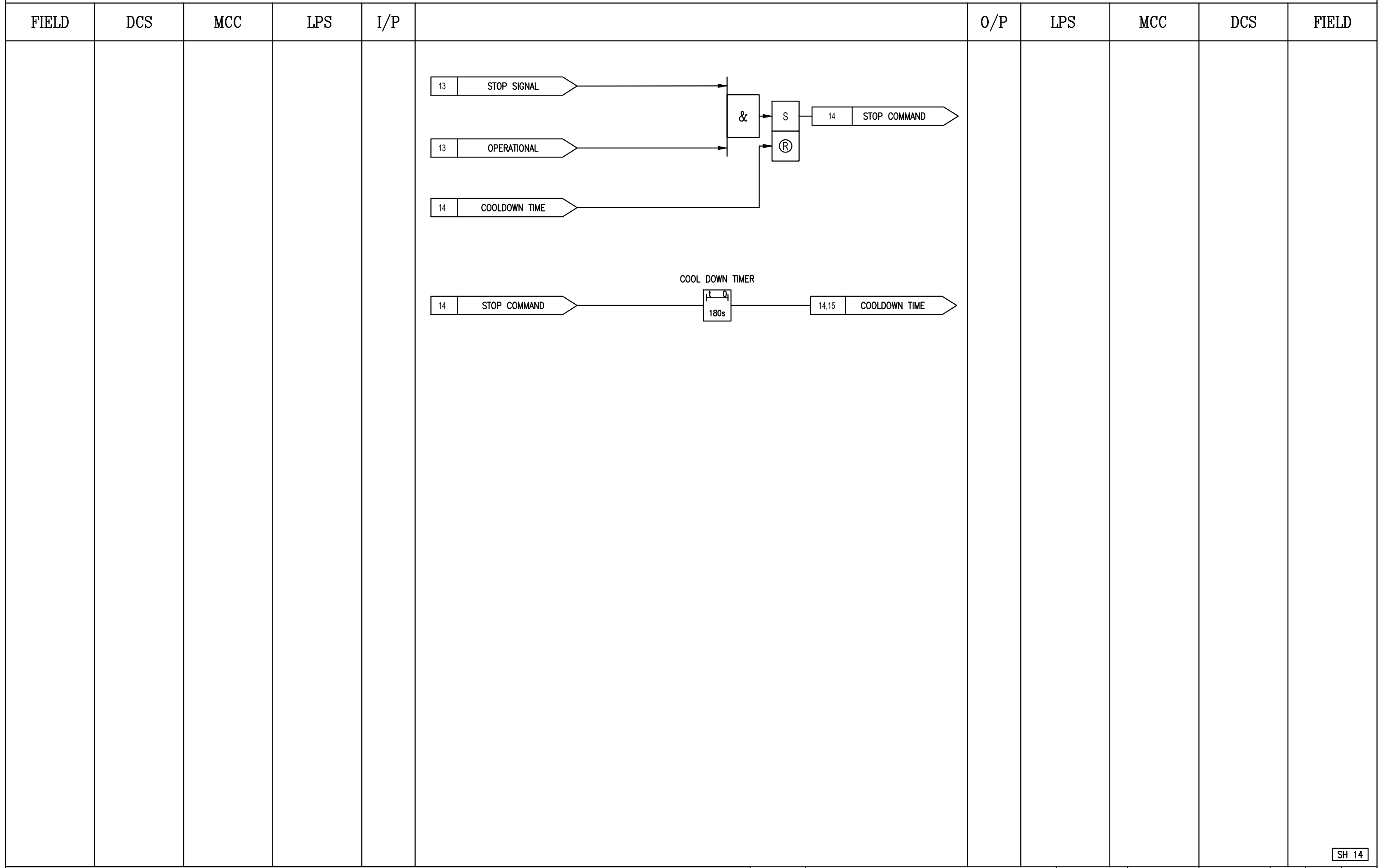

SH 14

NOTES:

1. -



SUBJECT		LOGIC DIAGRAM HIGH PRESSURE AIR COMPRESSOR K020	
CLIENT	Lavan Industry Development Company	DATE	08-03-2024
CLIENT REF	N-278-VD-6019-EL-DIA-0049	DRAWN BY	AZ
AIRPACK REF	17735-COM	CHECKED BY	SK
		PLANT LOCATION	IRAN, ONSHORE
		DRAWING NO.	17735-32
		SHEET NO.	14 / 17

THIS DRAWING IS OWNED BY AIRPACK AND SHALL NOT BE PRINTED OR COPIED IN ANY OTHER WAY THAN WITH AIRPACKS PERMISSION		
07	19-08-2024	AZ
06	06-08-2024	SK
05	18-07-2024	AZ
04	04-07-2024	AZ
03	01-05-2024	AZ
02	09-04-2024	AZ
01	08-03-2024	AZ

LOGIC DIAGRAM

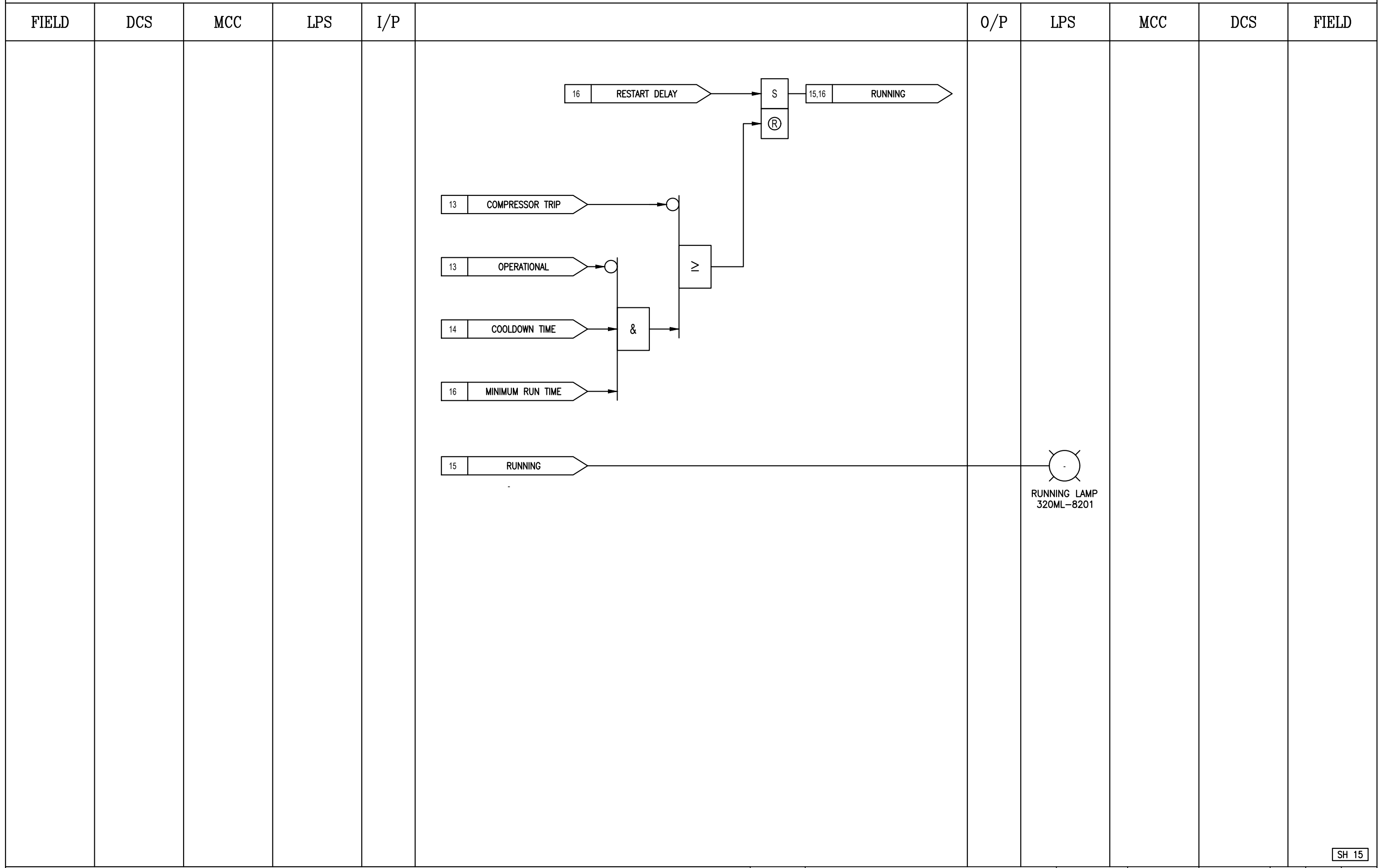

SH 15

NOTES:

1. -



SUBJECT		LOGIC DIAGRAM HIGH PRESSURE AIR COMPRESSOR K020	
CLIENT	Lavan Industry Development Company		
CLIENT REF	N-278-VD-6019-EL-DIA-0049		
AIRPACK REF	17735-COM		

DATE	08-03-2024
DRAWN BY	AZ
CHECKED BY	SK
PLANT LOCATION	IRAN, ONSHORE
DRAWING NO.	17735-32
SHEET NO.	15 / 17

THIS DRAWING IS OWNED BY AIRPACK AND SHALL NOT BE PRINTED OR COPIED IN ANY OTHER WAY THAN WITH AIRPACKS PERMISSION

07	19-08-2024	AZ
06	06-08-2024	SK
05	18-07-2024	AZ
04	04-07-2024	AZ
03	01-05-2024	AZ
02	09-04-2024	AZ
01	08-03-2024	AZ

LOGIC DIAGRAM

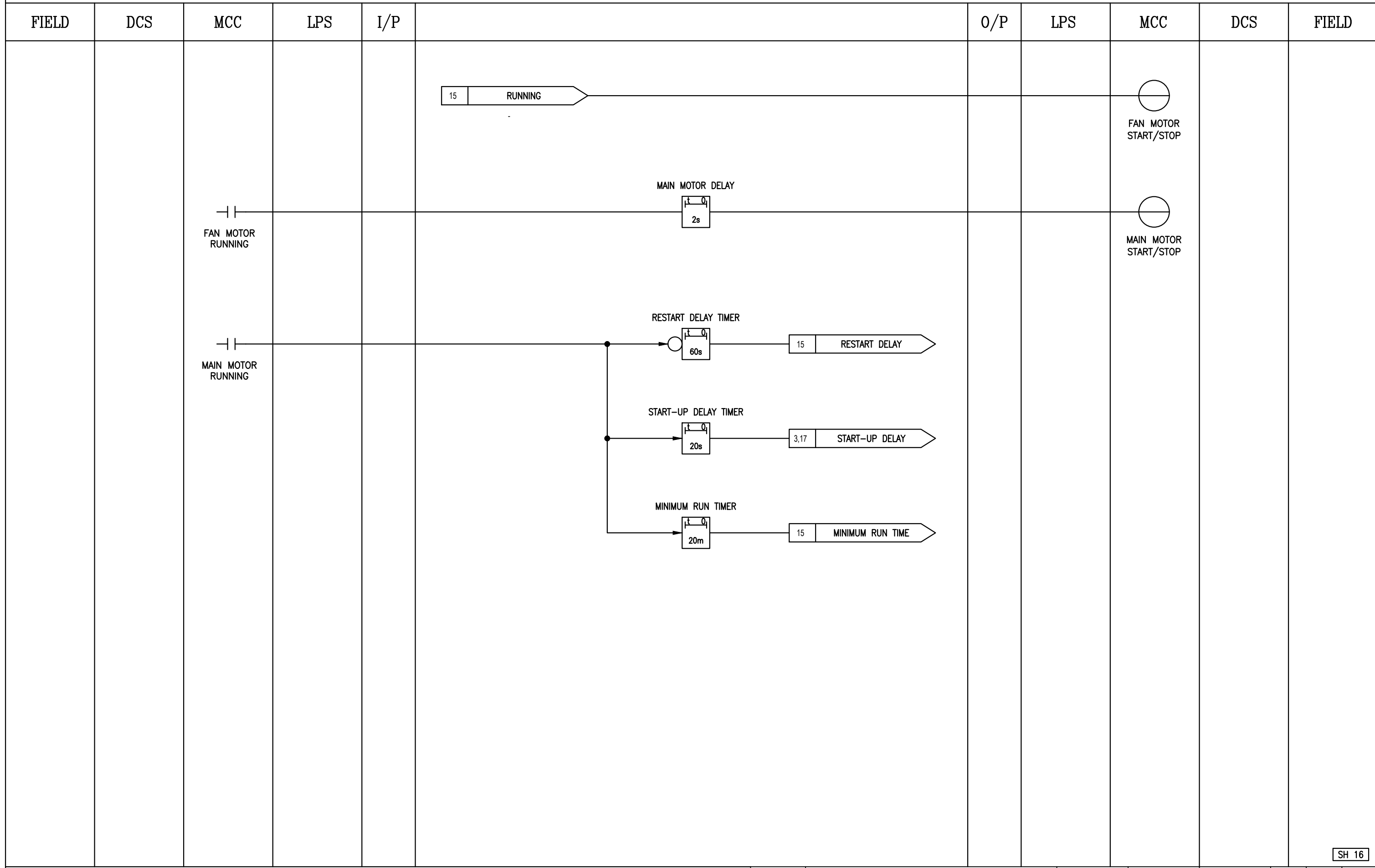

SH 16

NOTES:

1. -



SUBJECT		LOGIC DIAGRAM HIGH PRESSURE AIR COMPRESSOR K020	
CLIENT	Lavan Industry Development Company	DATE	08-03-2024
CLIENT REF	N-278-VD-6019-EL-DIA-0049	DRAWN BY	AZ
AIRPACK REF	17735-COM	CHECKED BY	SK
		PLANT LOCATION	IRAN, ONSHORE
		DRAWING NO.	17735-32
		SHEET NO.	16 / 17

THIS DRAWING IS OWNED BY AIRPACK AND SHALL NOT BE PRINTED OR COPIED IN ANY OTHER WAY THAN WITH AIRPACKS PERMISSION	07	19-08-2024	AZ
	06	06-08-2024	SK
	05	18-07-2024	AZ
	04	04-07-2024	AZ
	03	01-05-2024	AZ
	02	09-04-2024	AZ
	01	08-03-2024	AZ

LOGIC DIAGRAM

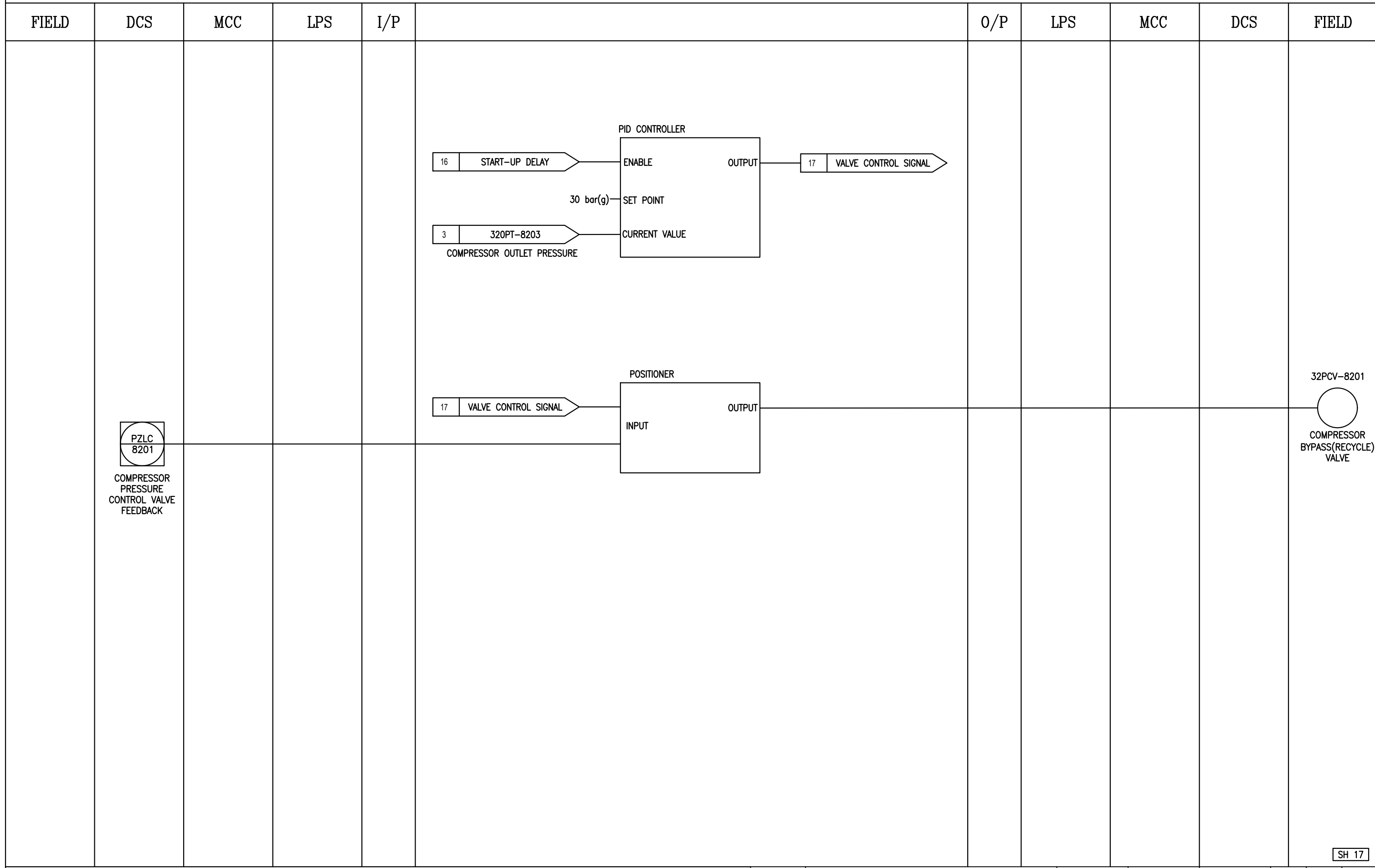

SH 17

NOTES:

1. -



SUBJECT		LOGIC DIAGRAM HIGH PRESSURE AIR COMPRESSOR K020	
CLIENT	Lavan Industry Development Company		
CLIENT REF	N-278-VD-6019-EL-DIA-0049		
AIRPACK REF	17735-COM		

DATE	08-03-2024
DRAWN BY	AZ
CHECKED BY	SK
PLANT LOCATION	IRAN, ONSHORE
DRAWING NO.	17735-32
SHEET NO.	17 / 17

THIS DRAWING IS OWNED BY AIRPACK AND SHALL NOT BE PRINTED OR COPIED IN ANY OTHER WAY THAN WITH AIRPACKS PERMISSION

07	19-08-2024	AZ
06	06-08-2024	SK
05	18-07-2024	AZ
04	04-07-2024	AZ
03	01-05-2024	AZ
02	09-04-2024	AZ
01	08-03-2024	AZ