



LIDCO, Pars SEE Zone, Assaluyeh,
Integrated Methanol and Ammonia
Plant 3000 MTPD MeOH / 900 MTPD NH3 PROJECT



Instrument Hook-up Drawing

Document No. 17735-38

Project No.	Vendor Doc.	P.O. No.	Department	Document Type	Serial No	Revision	Page
N278	VD	6019	IN	DWG	0035	03	Page 1 of 10

**Airpack B.V. - Air Compressor –
Integrated Methanol and Ammonia Plant
17735-COM Instrument Hook-up Drawing (K020)**

REV.	DATE	DESCRIPTION	DRAWN	CHECKED	APPROVED
03	18-03-2024	Issued for Approval	A.Z.	S.K.	J.J.
02	14-02-2024	Issued for Approval	A.Z.	S.K.	J.J.
01	07-12-2023	Issued for Approval	A.Z.	S.K.	J.J.

This document has been produced by Contractor for LIDCO. It is confidential and cannot be disclosed to or used by any third party for any purpose without prior written consent.

Instrument Hook-up Drawing

Document No. 17735-38

Project No.	Vendor Doc.	P.O. No.	Department	Document Type	Serial No	Revision	Page
N278	VD	6019	IN	DWG	0035	03	Page 2 of 10

LIST OF REVISED PAGES

Rev. Page	01	02	03	04	05	Rev. Page	01	02	03	04	05	Rev. Page	01	02	03	04	05	Rev. Page	01	02	03	04	05
1	X	X	X			26						51						76					
2	X	X	X			27						52						77					
3	X	X	X			28						53						78					
4	X	X	X			29						54						79					
5	X	X	X			30						55						80					
6	X	X	X			31						56						81					
7	X	X	X			32						57						82					
8	X	X	X			33						58						83					
9	X	X	X			34						59						84					
10			X			35						60						85					
11						36						61						86					
12						37						62						87					
13						38						63						88					
14						39						64						89					
15						40						65						90					
16						41						66						91					
17						42						67						92					
18						43						68						ATTACHMENT					
19						44						69						1					
20						45						70						2					
21						46						71						3					
22						47						72						4					
23						48						73						5					
24						49						74						6					
25						50						75						7					

PRESSURE GAUGE

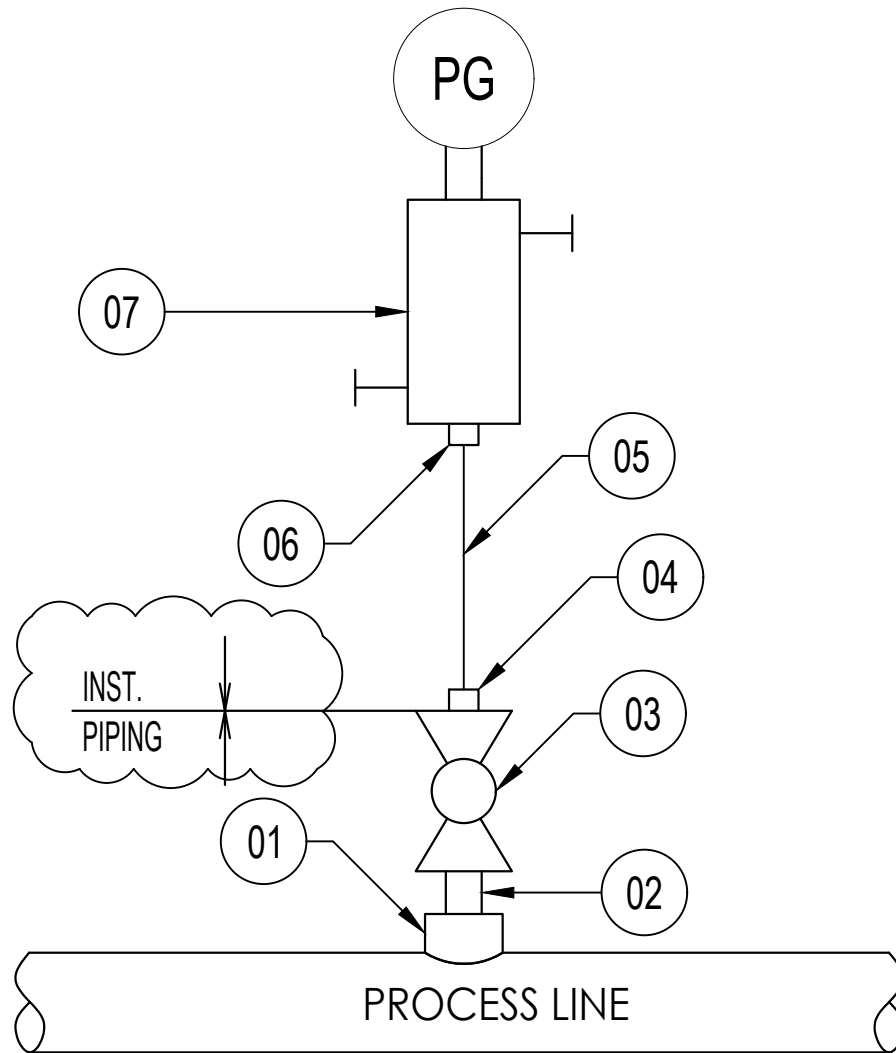

NOTE:
THESE PRESSURE GAUGES
ARE PANEL MOUNTED

ITEM	QTY	DESCRIPTION	SIZE	MATERIAL
01	01	PROCESS CONNECTION	3/4" NPT	SS316
02	01	HEX NIPPLE	3/4" NPT	SS316
03	01	BALL VALVE	3/4" NPT-F	SS316
04	01	CONNECTOR DOUBLE COMPRESSION TYPE	3/4"NPT-M-12mmOD	SS316
05	-	TUBING	12mmOD	SS316
06	01	CONNECTOR DOUBLE COMPRESSION TYPE	1/2"NPT-M-12mmOD	SS316
07	01	2-WAY BLOCK & BLEED MANIFOLD	1/2" NPT-F x 1/2" NPT-F	SS316
08				
09				

TAGNUMBERS:
320PG-8201, 320PG-8202, 320PG-8203, 320PG-8204

REFERENCE DOCUMENTS:
N-278-VD-6019-PR-PID-0002 P&ID
N-278-VD-6019-IN-DS-0013 INSTRUMENT DATA SHEETS

	SUBJECT		DATE		07-12-2023		THIS DRAWING IS OWNED BY AIRPACK AND SHALL NOT BE PRINTED OR COPIED IN ANY OTHER WAY THAN WITH AIRPACKS PERMISSION				
	HOOKUP PRESSURE GAUGE		DRAWN BY		AZ						
			CHECKED BY		SK						
	CLIENT	LAVAN INDUSTRY	PLANT LOCATION	IRAN ONSHORE					03	18-03-2024	AZ
	CLIENT REF	Integrated Methanol and Ammonia Plant	DRAWING NO.	17735-38					02	13-02-2024	AZ
AIRPACK REF	17735-COM	SHEETNO.	1				01	07-12-2023	AZ		

TEMPERATURE GAUGE LOCALLY MOUNTED

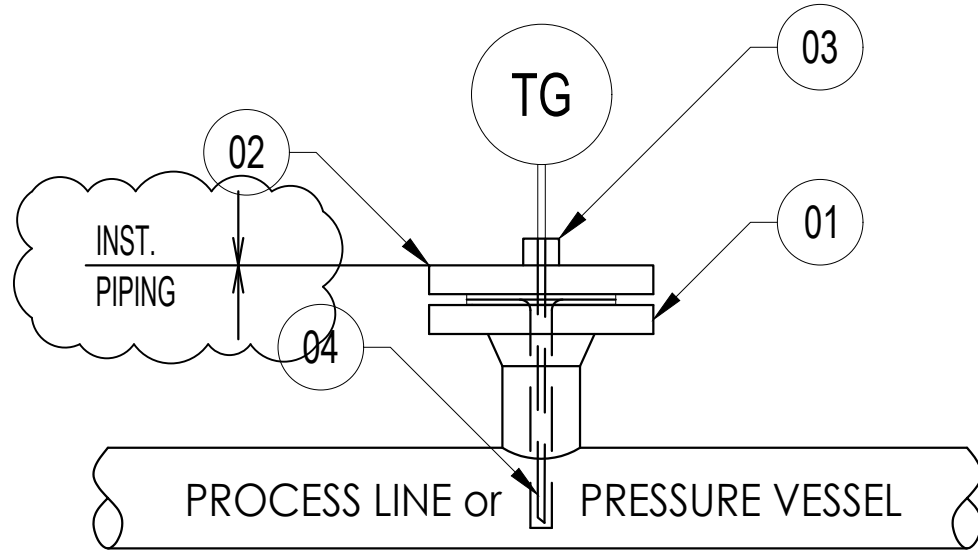

ITEM	QTY	DESCRIPTION	SIZE	MATERIAL
01	01	PROCESS CONNECTION	1 1/2" ANSI 300# RF	SS316
02	01	THERMOWELL	1 1/2" ANSI 300# RF	SS316
03	01	CONNECTOR DOUBLE COMPRESSION FITTING	3/4"NPT-M - 6mm OD	SS316
04	01	TEMPERATURE ELEMENT	N.A.	SS316
05				
06				
07				
08				
09				

TAGNUMBERS:
320TG-8206

REFERENCE DOCUMENTS:
N-278-VD-6019-PR-PID-0002 P&ID
N-278-VD-6019-IN-DS-0013 INSTRUMENT DATA SHEETS

	SUBJECT		DATE		07-12-2023		THIS DRAWING IS OWNED BY AIRPACK AND SHALL NOT BE PRINTED OR COPIED IN ANY OTHER WAY THAN WITH AIRPACKS PERMISSION			
	HOOKUP TEMPERATURE GAUGE		DRAWN BY		AZ					
			CHECKED BY		SK					
	CLIENT	LAVAN INDUSTRY	PLANT LOCATION		IRAN ONSHORE					
	CLIENT REF	Integrated Methanol and Ammonia Plant	DRAWING NO.		17735-38					
AIRPACK REF	17735-COM	SHEETNO.		2						
								03	18-03-2024	AZ
								02	13-02-2024	AZ
								01	07-12-2023	AZ

TEMPERATURE GAUGE REMOTE MOUNTED

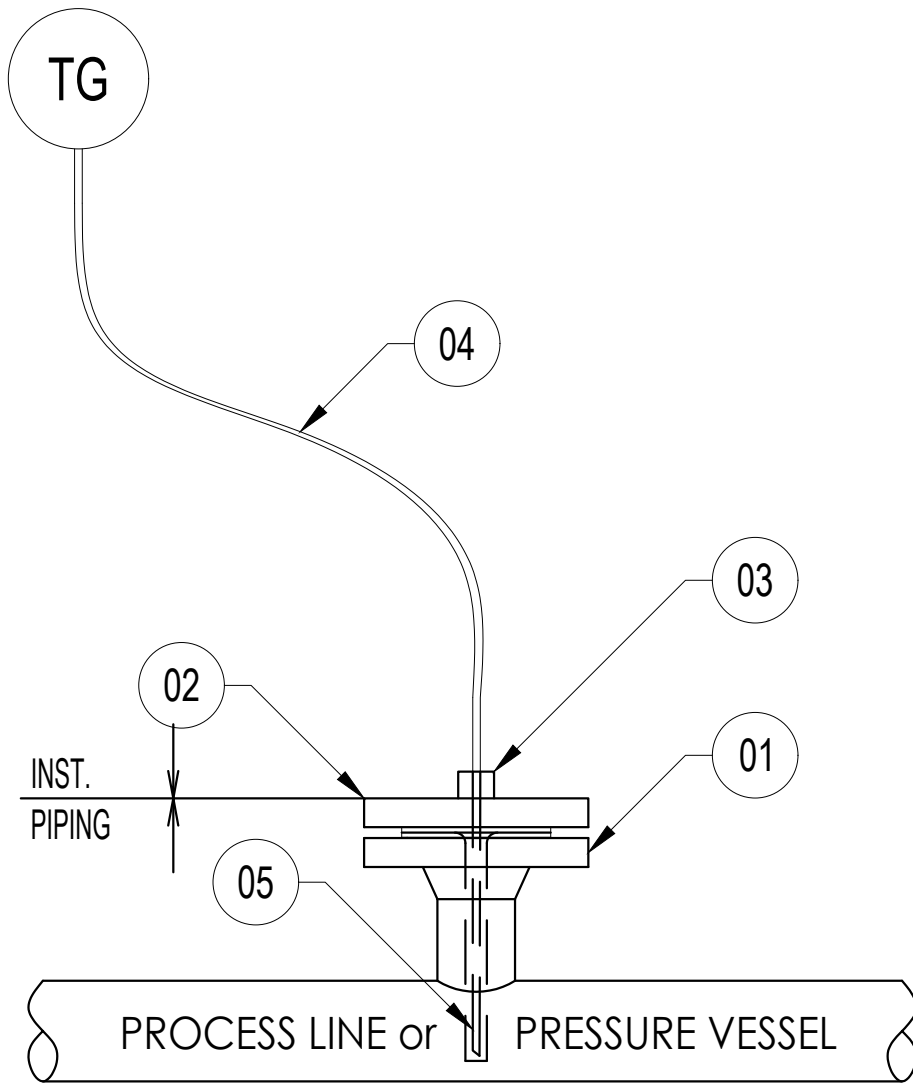

NOTE:
THESE TEMPERATURE GAUGES
ARE PANEL MOUNTED

ITEM	QTY	DESCRIPTION	SIZE	MATERIAL
01	01	PROCESS CONNECTION	1 1/2" ANSI 300# RF	SS316
02	01	THERMOWELL	1 1/2" ANSI 300# RF	SS316
03	01	CONNECTOR DOUBLE COMPRESSION FITTING	3/4"NPT-M - 6mm OD	SS316
04	01	CAPILLARY, MOULDED TO TEMPERATURE ELEMENT	L=5m	SS316
05	01	TEMPERATURE ELEMENT	N.A.	SS316
06				
07				
08				
09				

TAGNUMBERS:
320TG-8209, 320TG-8210, 320TG-8211

REFERENCE DOCUMENTS:
N-278-VD-6019-PR-PID-0002 P&ID
N-278-VD-6019-IN-DS-0013 INSTRUMENT DATA SHEETS

	SUBJECT		HOOKUP TEMPERATURE GAUGE		DATE	07-12-2023	THIS DRAWING IS OWNED BY AIRPACK AND SHALL NOT BE PRINTED OR COPIED IN ANY OTHER WAY THAN WITH AIRPACKS PERMISSION				
					DRAWN BY	AZ					
					CHECKED BY	SK					
	CLIENT	LAVAN INDUSTRY		PLANT LOCATION	IRAN ONSHORE				03	18-03-2024	AZ
	CLIENT REF	Integrated Methanol and Ammonia Plant		DRAWING NO.	17735-38				02	13-02-2024	AZ
AIRPACK REF	17735-COM		SHEETNO.	3			01	07-12-2023	AZ		

TEMPERATURE GAUGE LOCALLY MOUNTED

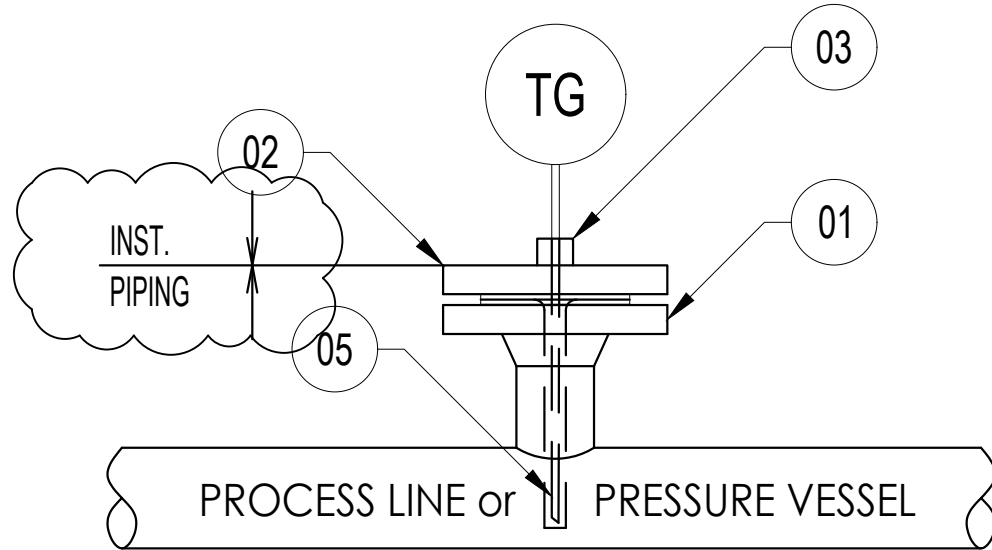

ITEM	QTY	DESCRIPTION	SIZE	MATERIAL
01	01	PROCESS CONNECTION	1 1/2" ANSI 600# RF	SS316
02	01	THERMOWELL	1 1/2" ANSI 600# RF	SS316
03	01	CONNECTOR DOUBLE COMPRESSION FITTING	3/4"NPT-M - 6mm OD	SS316
04	01	TEMPERATURE ELEMENT	N.A.	SS316
05				
06				
07				
08				
09				

TAGNUMBERS:
320TG-8207, 320TG-8208

REFERENCE DOCUMENTS:
N-278-VD-6019-PR-PID-0002 P&ID
N-278-VD-6019-IN-DS-0013 INSTRUMENT DATA SHEETS

	SUBJECT		HOOKUP TEMPERATURE GAUGE		DATE	07-12-2023	THIS DRAWING IS OWNED BY AIRPACK AND SHALL NOT BE PRINTED OR COPIED IN ANY OTHER WAY THAN WITH AIRPACKS PERMISSION				
	CLIENT		LAVAN INDUSTRY		DRAWN BY	AZ					
	CLIENT REF		Integrated Methanol and Ammonia Plant		CHECKED BY	SK					
	AIRPACK REF		17735-COM		PLANT LOCATION	IRAN ONSHORE			03	18-03-2024	AZ
					DRAWING NO.	17735-38			02	13-02-2024	AZ
				SHEETNO.	4		01	07-12-2023	AZ		

PRESSURE TRANSMITTER

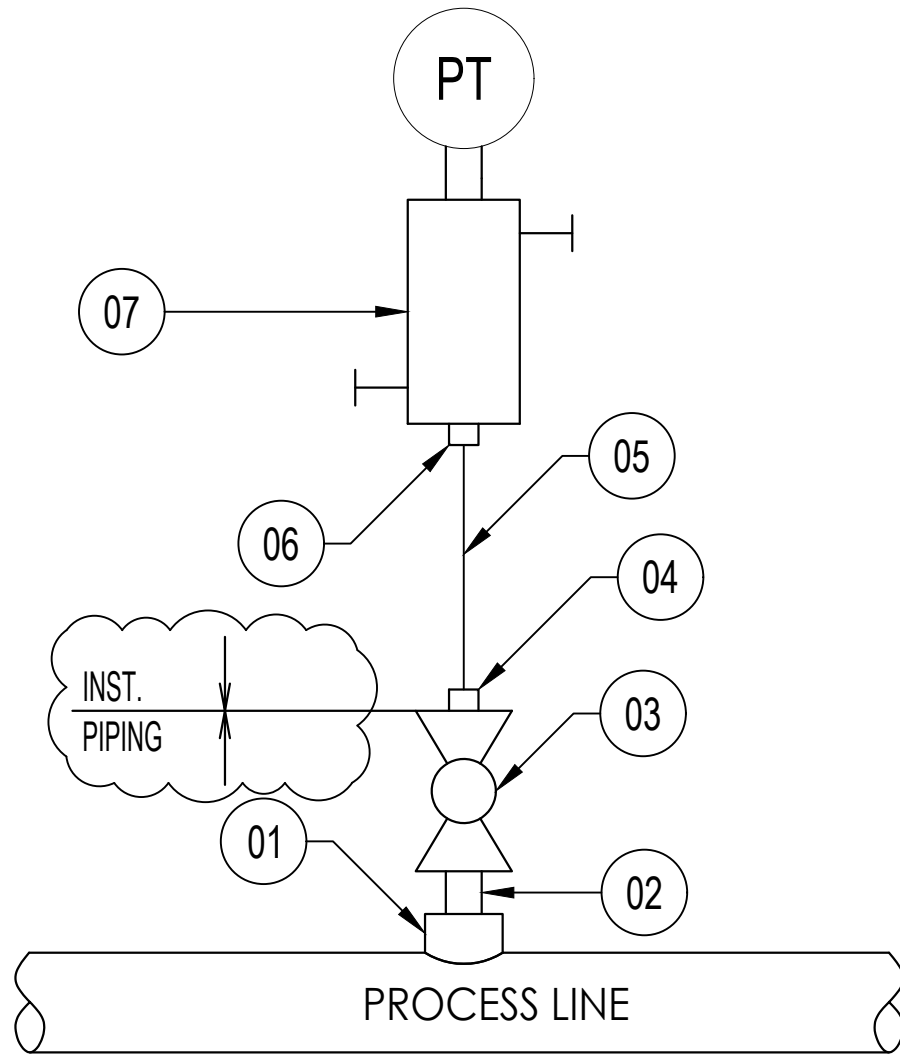

NOTE:
MOUNTING BRACKET TO BE
SUPPLIED FOR THESE
PRESSURE TRANSMITTERS.

ITEM	QTY	DESCRIPTION	SIZE	MATERIAL
01	01	PROCESS CONNECTION	3/4" NPT	SS316
02	01	HEX NIPPLE	3/4" NPT	SS316
03	01	BALL VALVE	3/4" NPT-F	SS316
04	01	CONNECTOR DOUBLE COMPRESSION TYPE	3/4"NPT-M-12mmOD	SS316
05	-	TUBING	12mmOD	SS316
06	01	CONNECTOR DOUBLE COMPRESSION TYPE	1/2"NPT-M-12mmOD	SS316
07	01	2-WAY BLOCK & BLEED MANIFOLD	1/2" NPT-F x 1/2" NPT-F	SS316
08				
09				

TAGNUMBERS:
320PT-8201, 320PT-8202, 320PT-8203, 320PT-8204

REFERENCE DOCUMENTS:
N-278-VD-6019-PR-PID-0002 P&ID
N-278-VD-6019-IN-DS-0013 INSTRUMENT DATA SHEETS

	SUBJECT		DATE		07-12-2023		THIS DRAWING IS OWNED BY AIRPACK AND SHALL NOT BE PRINTED OR COPIED IN ANY OTHER WAY THAN WITH AIRPACKS PERMISSION					
			HOOKUP PRESSURE TRANSMITTER		DRAWN BY			AZ				
					CHECKED BY			SK				
	CLIENT	LAVAN INDUSTRY		PLANT LOCATION		IRAN ONSHORE			03	18-03-2024	AZ	
	CLIENT REF	Integrated Methanol and Ammonia Plant		DRAWING NO.		17735-38			02	13-02-2024	AZ	
AIRPACK REF	17735-COM		SHEETNO.		5			01	07-12-2023	AZ		

TEMPERATURE TRANSMITTER REMOTE MOUNTED

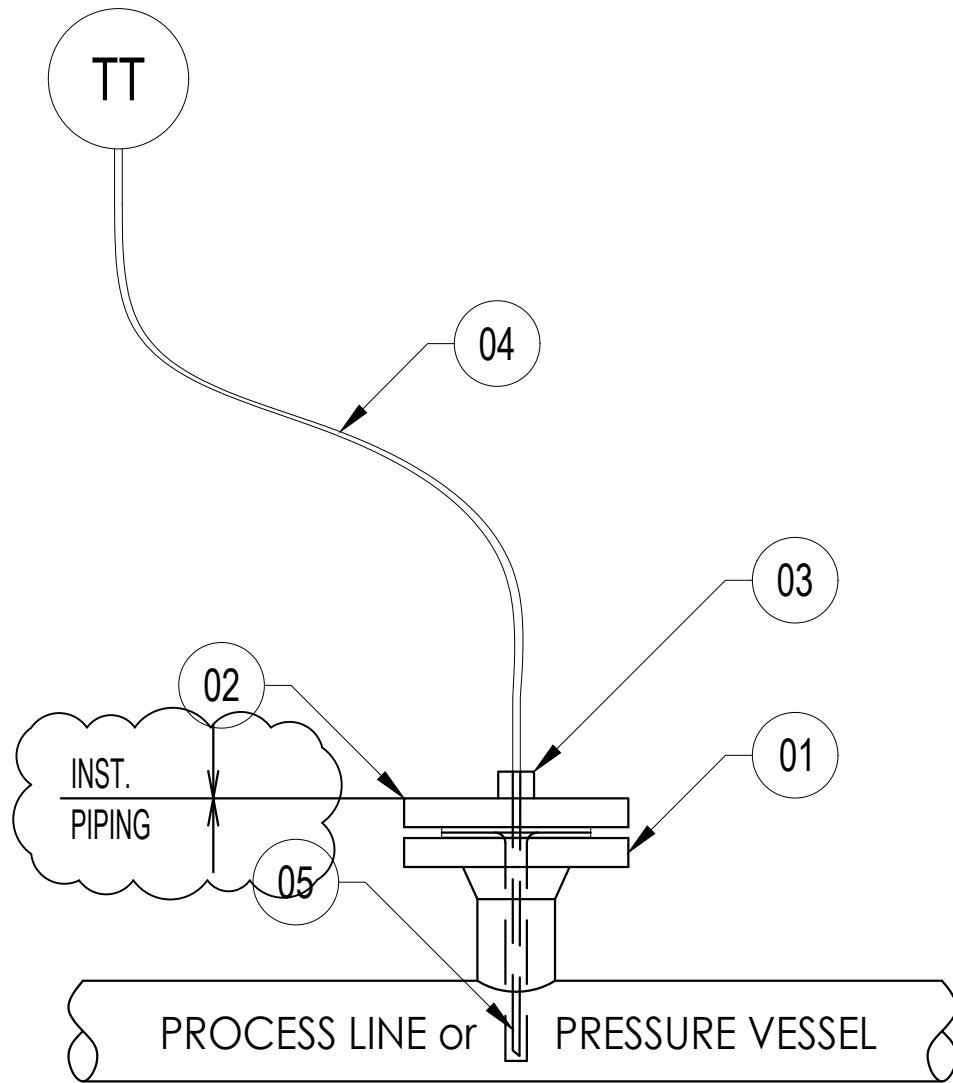

NOTE:
MOUNTING BRACKET TO BE
SUPPLIED FOR THESE
TEMPERATURE TRANSMITTERS.

ITEM	QTY	DESCRIPTION	SIZE	MATERIAL
01	01	PROCESS CONNECTION	1 1/2" ANSI 300# RF	SS316
02	01	THERMOWELL	1 1/2" ANSI 300# RF	SS316
03	01	CONNECTOR DOUBLE COMPRESSION FITTING	3/4"NPT-M - 6mm OD	SS316
04	01	CAPILLARY, MOULDED TO TEMPERATURE ELEMENT	L=5m	SS316
05	01	TEMPERATURE ELEMENT	N.A.	SS316
06				
07				
08				
09				

TAGNUMBERS:
320TT-8201, 320TT-8205

REFERENCE DOCUMENTS:
N-278-VD-6019-PR-PID-0002 P&ID
N-278-VD-6019-IN-DS-0013 INSTRUMENT DATA SHEETS

	SUBJECT	DATE	07-12-2023	THIS DRAWING IS OWNED BY AIRPACK AND SHALL NOT BE PRINTED OR COPIED IN ANY OTHER WAY THAN WITH AIRPACKS PERMISSION			
		HOOKUP TEMPERATURE TRANSMITTER	DRAWN BY		AZ		
			CHECKED BY		SK		
	CLIENT	LAVAN INDUSTRY	PLANT LOCATION		IRAN ONSHORE	03	18-03-2024
CLIENT REF	Integrated Methanol and Ammonia Plant	DRAWING NO.	17735-38	02	13-02-2024	AZ	
AIRPACK REF	17735-COM	SHEETNO.	6	01	07-12-2023	AZ	

TEMPERATURE TRANSMITTER REMOTE MOUNTED

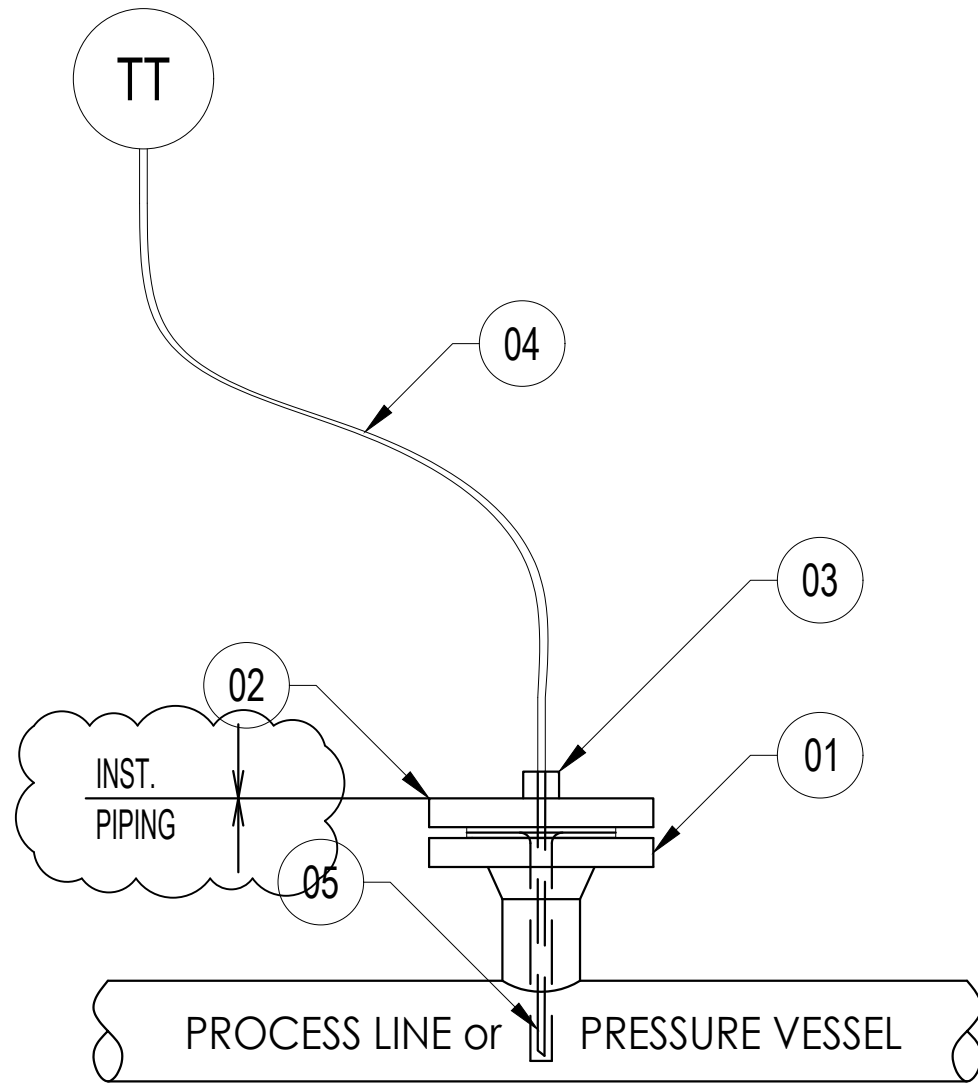

NOTE:
MOUNTING BRACKET TO BE
SUPPLIED FOR THESE
TEMPERATURE TRANSMITTERS.

ITEM	QTY	DESCRIPTION	SIZE	MATERIAL
01	01	PROCESS CONNECTION	1 1/2" ANSI 600# RF	SS316
02	01	THERMOWELL	1 1/2" ANSI 600# RF	SS316
03	01	CONNECTOR DOUBLE COMPRESSION FITTING	3/4"NPT-M - 6mm OD	SS316
04	01	CAPILLARY, MOULDED TO TEMPERATURE ELEMENT	L=5m	SS316
05	01	TEMPERATURE ELEMENT	N.A.	SS316
06				
07				
08				
09				

TAGNUMBERS:
320TT-8202, 320TT-8203, 320TT-8204

REFERENCE DOCUMENTS:
N-278-VD-6019-PR-PID-0002 P&ID
N-278-VD-6019-IN-DS-0013 INSTRUMENT DATA SHEETS

	SUBJECT	DATE	07-12-2023	THIS DRAWING IS OWNED BY AIRPACK AND SHALL NOT BE PRINTED OR COPIED IN ANY OTHER WAY THAN WITH AIRPACKS PERMISSION				
		HOOKUP TEMPERATURE TRANSMITTER	DRAWN BY		AZ			
			CHECKED BY		SK			
	CLIENT	LAVAN INDUSTRY	PLANT LOCATION		IRAN ONSHORE	03	18-03-2024	AZ
	CLIENT REF	Integrated Methanol and Ammonia Plant	DRAWING NO.		17735-38	02	13-02-2024	AZ
AIRPACK REF	17735-COM	SHEETNO.	7	01	07-12-2023	AZ		

PRESSURE BYPASS (RECYCLE) VALVE

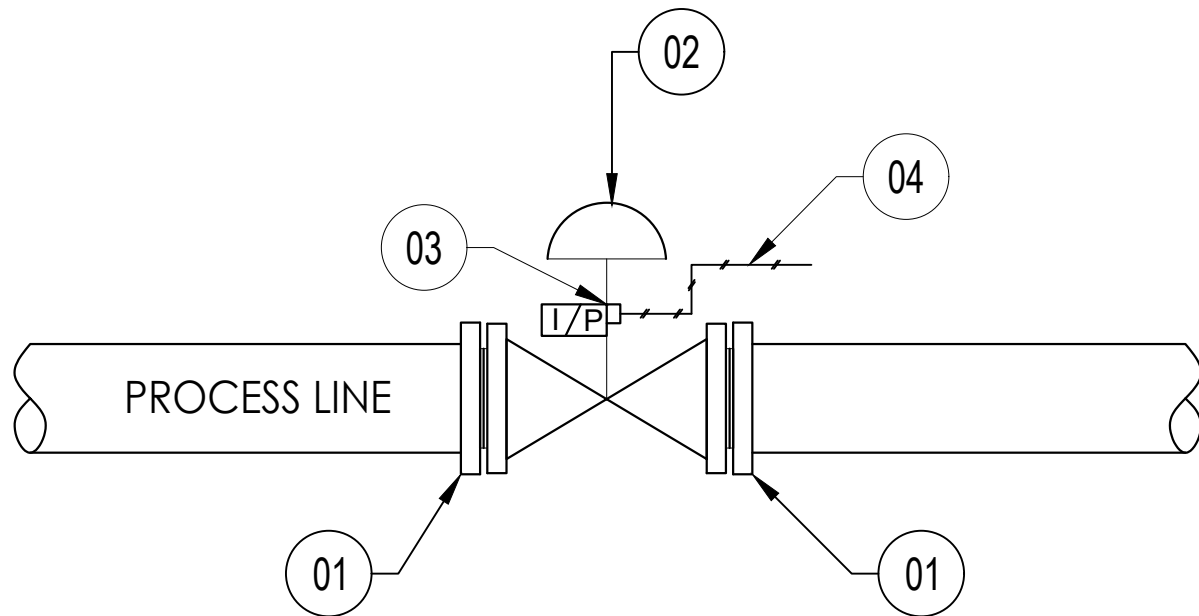

ITEM	QTY	DESCRIPTION	SIZE	MATERIAL
01	02	PROCESS CONNECTION	3/4" ANSI 300# RF	SS316
02	01	PRESSURE CONTROL VALVE	3/4"ANSI 300# RF	SS316
03	01	CONNECTOR DOUBLE COMPRESSION TYPE	1/4"NPT-M- 12mmOD	SS316
04	-	TUBING	12mmOD	SS316
05				
06				
07				
08				
09				

TAGNUMBERS:
320PCV-8201

REFERENCE DOCUMENTS:

N-278-VD-6019-PR-PID-0002 P&ID
N-278-VD-6019-IN-DS-0041 CONTROL VALVE DATA SHEETS

	SUBJECT	DATE	07-12-2023	THIS DRAWING IS OWNED BY AIRPACK AND SHALL NOT BE PRINTED OR COPIED IN ANY OTHER WAY THAN WITH AIRPACKS PERMISSION			
		HOOKUP PRESSURE BYPASS (RECYCLE) VALVE	DRAWN BY		AZ		
			CHECKED BY		SK		
	CLIENT	LAVAN INDUSTRY	PLANT LOCATION		IRAN ONSHORE	03	18-03-2024
CLIENT REF	Integrated Methanol and Ammonia Plant	DRAWING NO.	17735-38	02	13-02-2024	AZ	
AIRPACK REF	17735-COM	SHEETNO.	8	01	07-12-2023	AZ	