







OWNER: 	BUSHEHR PETROCHEMICAL COMPANY MEG PLANT							EPC CONTRACTOR:  Chagalesh-Enerchimi-Steam Joint Venture BUPC-MEG PLANT PROJECT	
	Logic diagrams – program of UCP- compressor shutdown logic drawing for reciprocating compressor								
MC:   شرکت سفت و سوی توسعه ایرانیان	Project	Area	Phase	Unit	Dis.	Doc.	Seq.	Contract No : 52-98/445	
Owner Document Number: 17811-32	BU	20	VD	303	IN	DIG	0035	Rev.:	Page
								00	1 of 14

Prerequisite document such as cause & effect, control philosophy and I/O list shall be issued.





Drawing shall be match the title of the project block

This document is checked only for compressor 7080. New document should be generated for compressor 1002.

Logic diagrams – program of UCP-compressor shutdown logic drawing for reciprocating compressor

 		BUSHEHR PETROCHEMICAL COMPANY MEG PLANT
Document Review		
Issue Purpose:	FA	
Result Code: AP,AN,CM,RE,NC	CM	
Next Status : IFC,IFA,IFI,AFC,AB	IFA	
Responsible Department	MECHANICAL	
Commented Date	May.05.2021	
Approval or review hereunder shall not be construed to relieve Vendor / Subcontractor of his responsibilities and liability under the contract.		

00	24/11/2020	For Approval	TJ	RB	KP	
Rev.	Date	Purpose of Issue	Prepared	Checked	Approved	AC Code
					Class: 1	Phase: 1p

OWNER  شرکت پتروشیمی بوتهر	BUSHEHR PETROCHEMICAL COMPANY MEG PLANT							EPC CONTRACTOR: 	
	Logic diagrams – program of UCP- compressor shutdown logic drawing for reciprocating compressor								
MC :   شرکت سفت و سوی توسعه ایرانیان	Project	Area	Phase	Unit	Dis.	Doc.	Seq.	Contract No : 52-98/445	
Owner Document Number: 17811-32	BU	20	VD	303	IN	DIG	0035	Rev.:	Page
								00	2 of 14

TABULATION OF REVISED PAGES

Page	D00	D01	D02	D03	D04
1.	X				
2.	X				
3.	X				
4.	X				
5.	X				
6.	X				
7.	X				
8.	X				
9.	X				
10.	X				
11.	X				
12.	X				
13.	X				
14.	X				
15.					
16.					
17.					
18.					
19.					
20.					
21.					
22.					
23.					
24.					
25.					
26.					
27.					
28.					
29.					
30.					
31.					
32.					
33.					
34.					

Page	D00	D01	D02	D03	D04
35.					
36.					
37.					
38.					
39.					
40.					
41.					
42.					
43.					
44.					
45.					
46.					
47.					
48.					
49.					
50.					
51.					
52.					
53.					
54.					
55.					
56.					
57.					
58.					
59.					
60.					
61.					
62.					
63.					
64.					
65.					
66.					
67.					

SYMBOL	FUNCTION	DESCRIPTION
	AND	OUTPUT D EXISTS ONLY IF AND WHILE INPUTS A,B AND C EXIST.
	OR	OUTPUT D EXISTS ONLY IF AND WHILE ONE OR MORE OF INPUTS A,B OR C EXIST.
	XOR	OUTPUT D EXISTS ONLY IF AND WHILE ONE OF INPUTS A,B OR C EXIST.
	NOT	OUTPUT B EXISTS ONLY IF AND WHILE INPUT A DOES NOT EXIST.
	TIMER (DELAY INITIATION)	THE CONTINUOUS EXISTENCE OF INPUT A FOR TIME T CAUSES OUTPUT B TO EXIST WHEN THE TIME T EXPIRES. B TERMINATES IMMEDIATELY WHEN A TERMINATES.
	TIMER (DELAY TERMINATION)	THE EXISTENCE OF INPUT A CAUSES OUTPUT B TO EXIST IMMEDIATELY. B TERMINATES WHEN A HAS TERMINATED AND HAS NOT AGAIN EXISTED FOR TIME T.
	PULSE OUTPUT	THE EXISTENCE OF INPUT A CAUSES OUTPUT B TO EXIST IMMEDIATELY. B EXISTS FOR TIME T, REGARDLESS OF THE STATE OF A.
	FLIP-FLOP MEMORY (SET PRIORITY)	OUTPUT C EXISTS AS SOON AS A EXISTS. C CONTINUES TO EXIST, REGARDLESS OF THE SUBSEQUENT STATE OF A, UNTIL THE MEMORY IS RESET (I.E; TERMINATED BY B EXISTING) C REMAINS TERMINATED, REGARDLESS OF THE SUBSEQUENT STATE OF B, UNTIL A CAUSES THE MEMORY TO BE SET. IF A AND B EXIST SIMULTANEOUSLY, A OVERRIDES B.
	FLIP-FLOP MEMORY (RESET PRIORITY)	OUTPUT C EXISTS AS SOON AS A EXISTS. C CONTINUES TO EXIST, REGARDLESS OF THE SUBSEQUENT STATE OF A, UNTIL THE MEMORY IS RESET (I.E; TERMINATED BY B EXISTING) C REMAINS TERMINATED, REGARDLESS OF THE SUBSEQUENT STATE OF B, UNTIL A CAUSES THE MEMORY TO BE SET. IF A AND B EXIST SIMULTANEOUSLY, B OVERRIDES A.
		LOGIC CONNECTION
		NO CONNECTION
		SERIAL LINK / FOUNDATION FIELDBUS PROTOCOL

SYMBOL	DESCRIPTION
	EMERGENCY PUSHBUTTON, RED HEAD, STAY PUT.
	TOGGLE SWITCH
	PUSHBUTTON MOMENTARILY MAKE
	PUSHBUTTON MOMENTARILY BREAK
	CONTACT NORMALLY OPEN
	CONTACT NORMALLY CLOSED
	HARDWIRED INPUT/OUTPUT
	SOLENOID VALVE, 3-WAY
	DISTRIBUTED CONTROL SYSTEM
	PLC CONTROL SYSTEM
	DCS AUXILIARY CONSOLE
	LAMP
	HMI
	AUDIBLE ALARM
	RELAY COIL

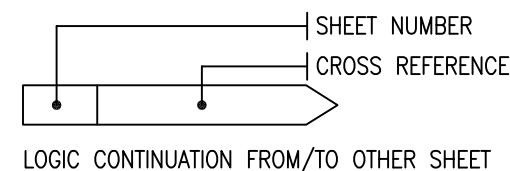

ABBREVIATIONS

DCS : DISTRIBUTED CONTROL SYSTEM
 UCP : UNIT CONTROL PANEL
 LCP : LOCAL CONTROL PANEL
 PLC : PROGRAMMABLE LOGIC CONTROLLER
 I/P : INPUT
 O/P : OUTPUT
 ESD : EMERGENCY SHUTDOWN
 MCC : MOTOR CONTROL CENTRE

GENERAL NOTES

- SHUTDOWN CONDITION ;
0 = SHUTDOWN 1 = OPERATING
- ALARM/TRIP CONDITION ;
0 = ALARM 1=NORMAL
0 = TRIP 1=NORMAL
- REMOTE/LOCAL CONDITION ;
0 = LOCAL 1=REMOTE

DEFINITION

-
-

SH 1



SUBJECT	BUSHEHR PETROCHEMICAL COMPANY MEG PLANT NITROGEN COMPRESSOR	DATE	20-11-2020
CLIENT	BUSHEHR PETROCHEMICAL COMPANY (BUPC)	DRAWN BY	TJ
CLIENT REF	20-C-1002	CHECKED BY	KP
AIRPACK REF	17811	PLANT LOCATION	IRAN
		DRAWING NO.	17811-32
		SHEETNO.	01 / 12

THIS DRAWING IS OWNED BY AIRPACK AND SHALL NOT BE PRINTED OR COPIED IN ANY OTHER WAY THAN WITH AIRPACKS PERMISSION

REV 00 20-11-2020 TJ

LOGIC DIAGRAM

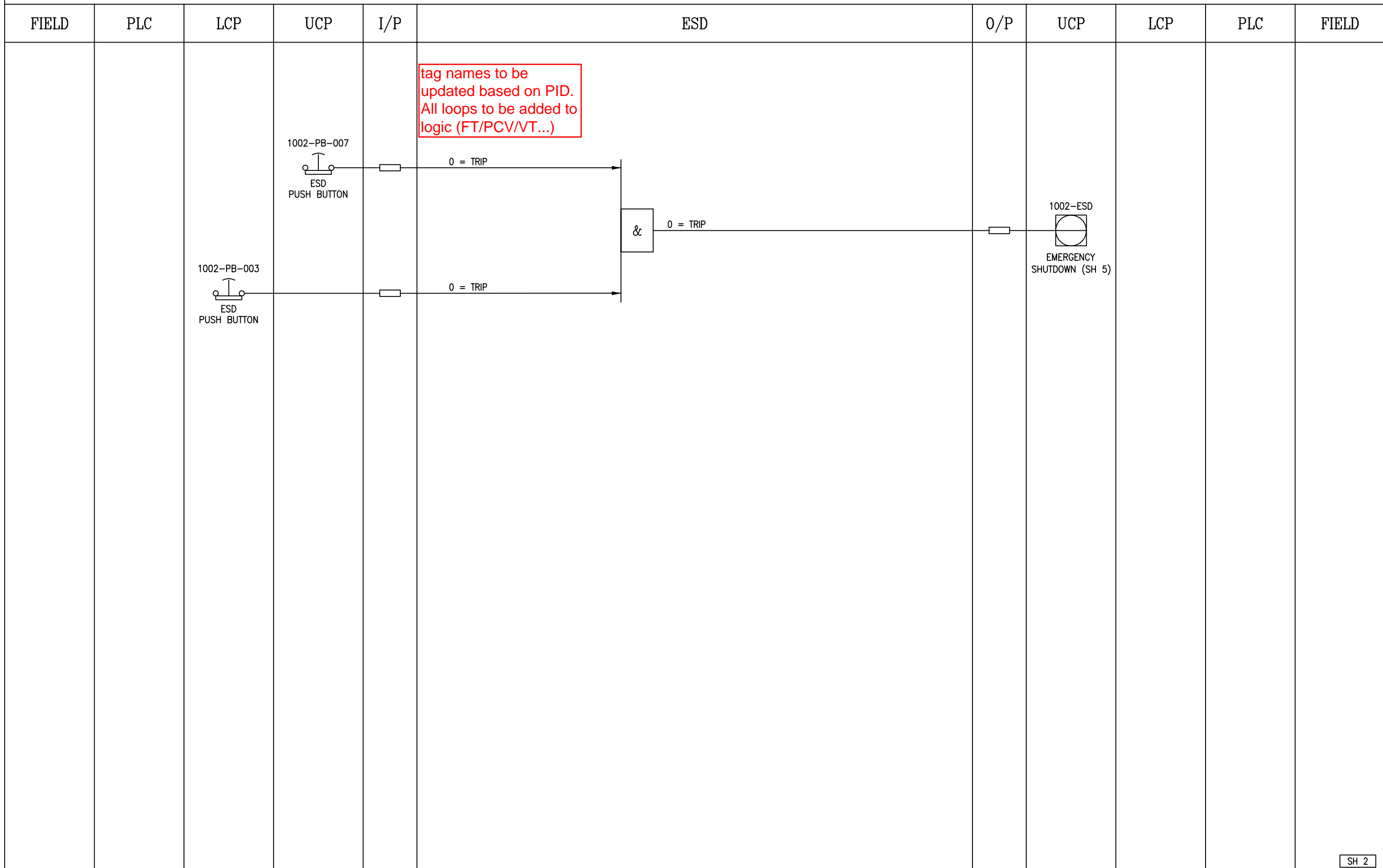

tag names to be updated based on PID. All loops to be added to logic (FT/PCV/VT...)

NOTES:

	SUBJECT	BUSHEHR PETROCHEMICAL COMPANY MEG PLANT NITROGEN COMPRESSOR	DATE	20-11-2020	THIS DRAWING IS OWNED BY AIRPACK AND SHALL NOT BE PRINTED OR COPIED IN ANY OTHER WAY THAN WITH AIRPACKS PERMISSION
	CLIENT	BUSHEHR PETROCHEMICAL COMPANY (BUPC)	CHECKED BY	KP	
	CLIENT REF	20-C-1002	DRAWING NO.	17811-32	
	AIRPACK REF	17811	SHEETNO.	02 / 12	
			REV 00	20-11-2020	TJ

LOGIC DIAGRAM

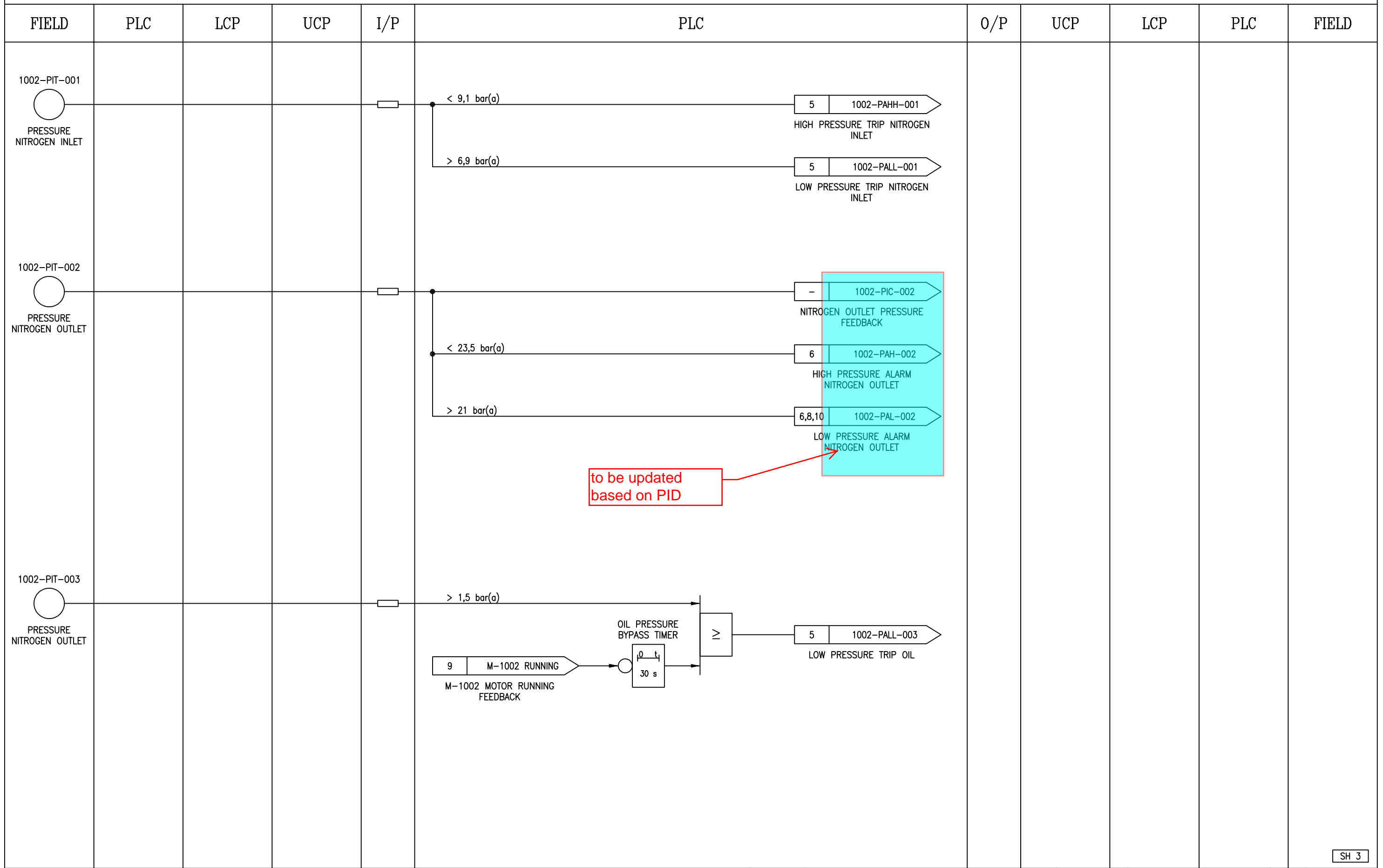

to be updated based on PID

NOTES:

	SUBJECT	BUSHEHR PETROCHEMICAL COMPANY MEG PLANT NITROGEN COMPRESSOR	DATE	20-11-2020	<p>THIS DRAWING IS OWNED BY AIRPACK AND SHALL NOT BE PRINTED OR COPIED IN ANY OTHER WAY THAN WITH AIRPACKS PERMISSION</p>
	CLIENT	BUSHEHR PETROCHEMICAL COMPANY (BUPC)	DRAWN BY	TJ	
	CLIENT REF	20-C-1002	CHECKED BY	KP	
	AIRPACK REF	17811	PLANT LOCATION	IRAN	
			DRAWING NO.	17811-32	
			SHEETNO.	03 / 12	
			REV 00	20-11-2020	TJ

LOGIC DIAGRAM

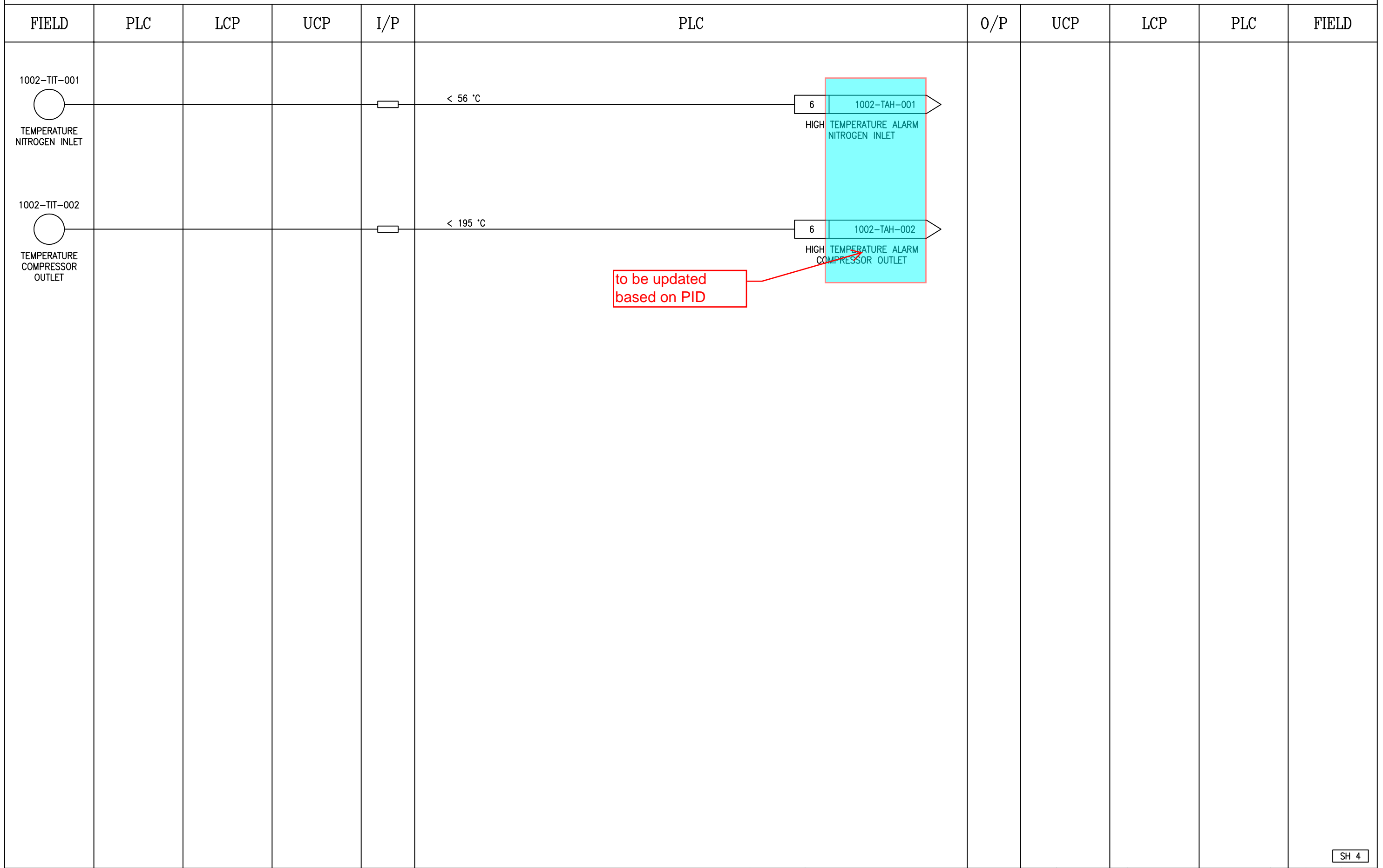

NOTES:

	SUBJECT BUSHEHR PETROCHEMICAL COMPANY MEG PLANT NITROGEN COMPRESSOR		DATE 20-11-2020	THIS DRAWING IS OWNED BY AIRPACK AND SHALL NOT BE PRINTED OR COPIED IN ANY OTHER WAY THAN WITH AIRPACKS PERMISSION
	CLIENT BUSHEHR PETROCHEMICAL COMPANY (BUPC)	PLANT LOCATION IRAN	DRAWN BY TJ	
	CLIENT REF 20-C-1002	DRAWING NO. 17811-32	CHECKED BY KP	
	AIRPACK REF 17811	SHEETNO. 04 / 12		
	REV 00	20-11-2020	TJ	

LOGIC DIAGRAM

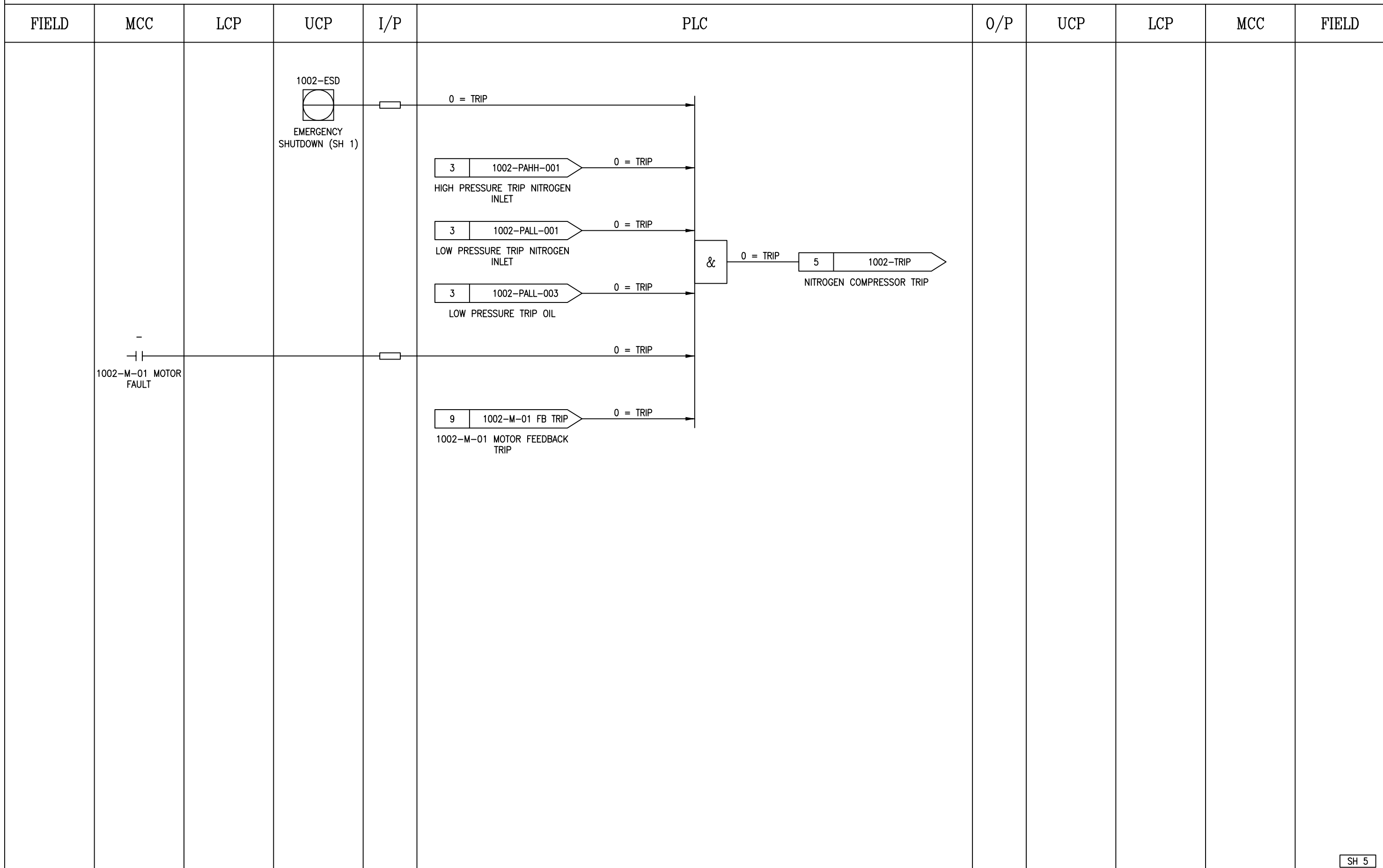

SH 5

NOTES:



SUBJECT		BUSHEHR PETROCHEMICAL COMPANY MEG PLANT NITROGEN COMPRESSOR	
CLIENT	BUSHEHR PETROCHEMICAL COMPANY (BUPC)	PLANT LOCATION	IRAN
CLIENT REF	20-C-1002	DRAWING NO.	17811-32
AIRPACK REF	17811	SHEETNO.	05 / 12

DATE	20-11-2020
DRAWN BY	TJ
CHECKED BY	KP
REV 00	20-11-2020 TJ

THIS DRAWING IS OWNED BY AIRPACK AND SHALL NOT BE PRINTED OR COPIED IN ANY OTHER WAY THAN WITH AIRPACKS PERMISSION

REV 00	20-11-2020	TJ		

LOGIC DIAGRAM

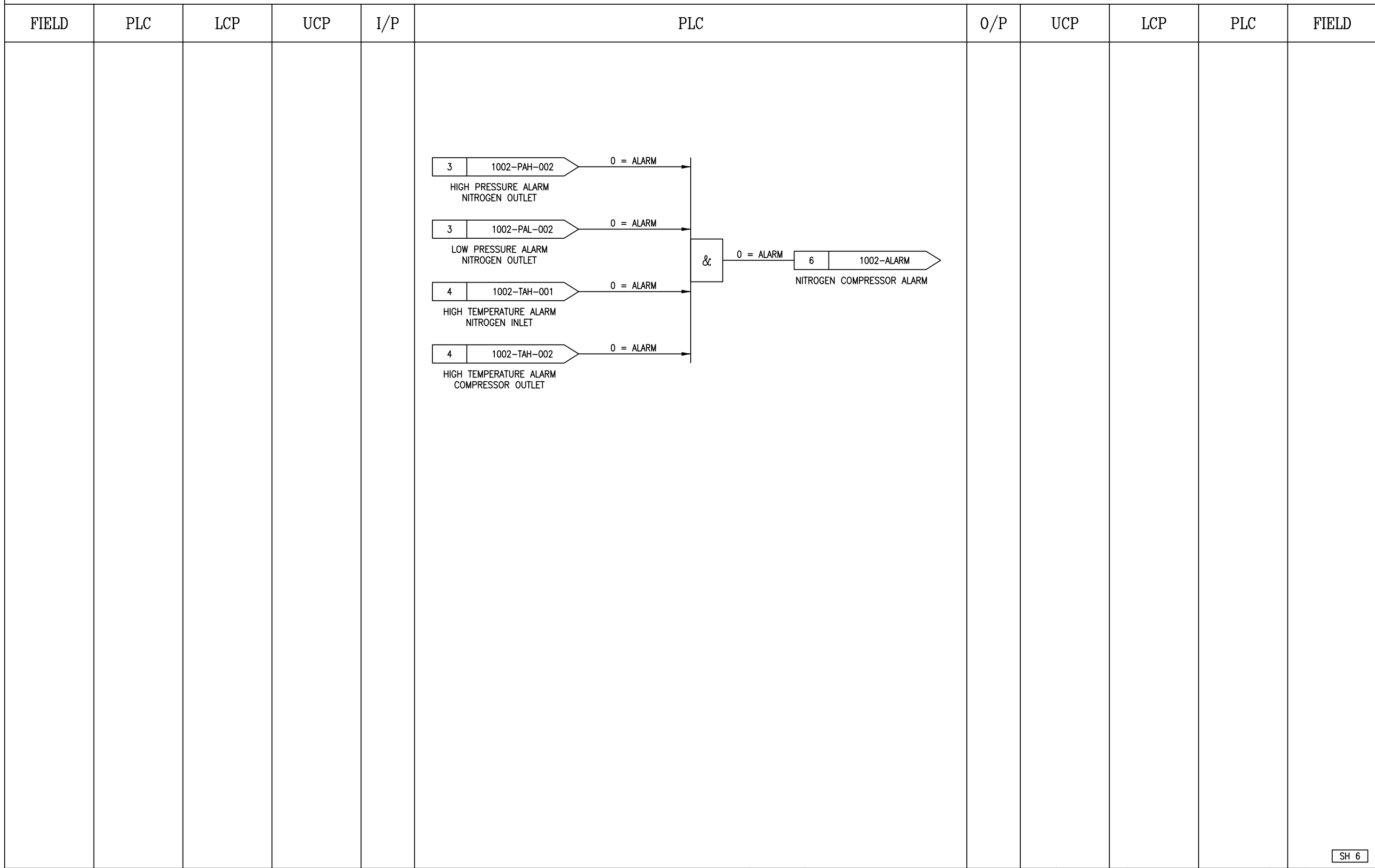

SH 6

NOTES:

	SUBJECT BUSHEHR PETROCHEMICAL COMPANY MEG PLANT NITROGEN COMPRESSOR		DATE 20-11-2020	THIS DRAWING IS OWNED BY AIRPACK AND SHALL NOT BE PRINTED OR COPIED IN ANY OTHER WAY THAN WITH AIRPACKS PERMISSION	
	CLIENT BUSHEHR PETROCHEMICAL COMPANY (BUPC)	PLANT LOCATION IRAN	DRAWN BY TJ		
	CLIENT REF 20-C-1002	DRAWING NO. 17811-32	CHECKED BY KP		
	AIRPACK REF 17811	SHEETNO. 06 / 12			
			REV 00	20-11-2020	TJ

LOGIC DIAGRAM

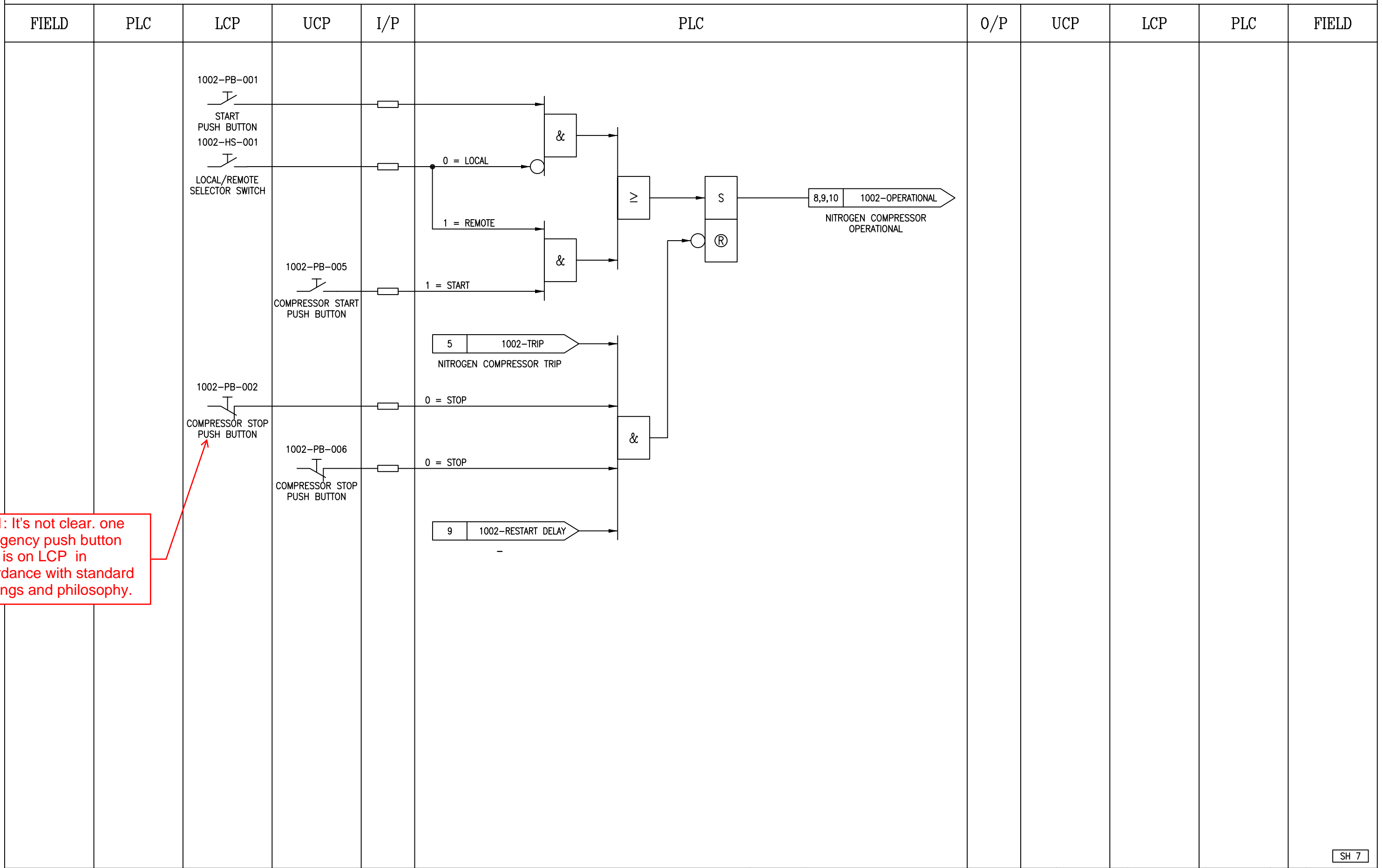

EL.01: It's not clear. one Emergency push button there is on LCP in accordance with standard drawings and philosophy.

NOTES:

	SUBJECT BUSHEHR PETROCHEMICAL COMPANY MEG PLANT NITROGEN COMPRESSOR		DATE 20-11-2020	THIS DRAWING IS OWNED BY AIRPACK AND SHALL NOT BE PRINTED OR COPIED IN ANY OTHER WAY THAN WITH AIRPACKS PERMISSION
	CLIENT BUSHEHR PETROCHEMICAL COMPANY (BUPC)	PLANT LOCATION IRAN	DRAWN BY TJ	
CLIENT REF 20-C-1002	DRAWING NO. 17811-32	CHECKED BY KP		
AIRPACK REF 17811	SHEETNO. 07 / 12			

LOGIC DIAGRAM

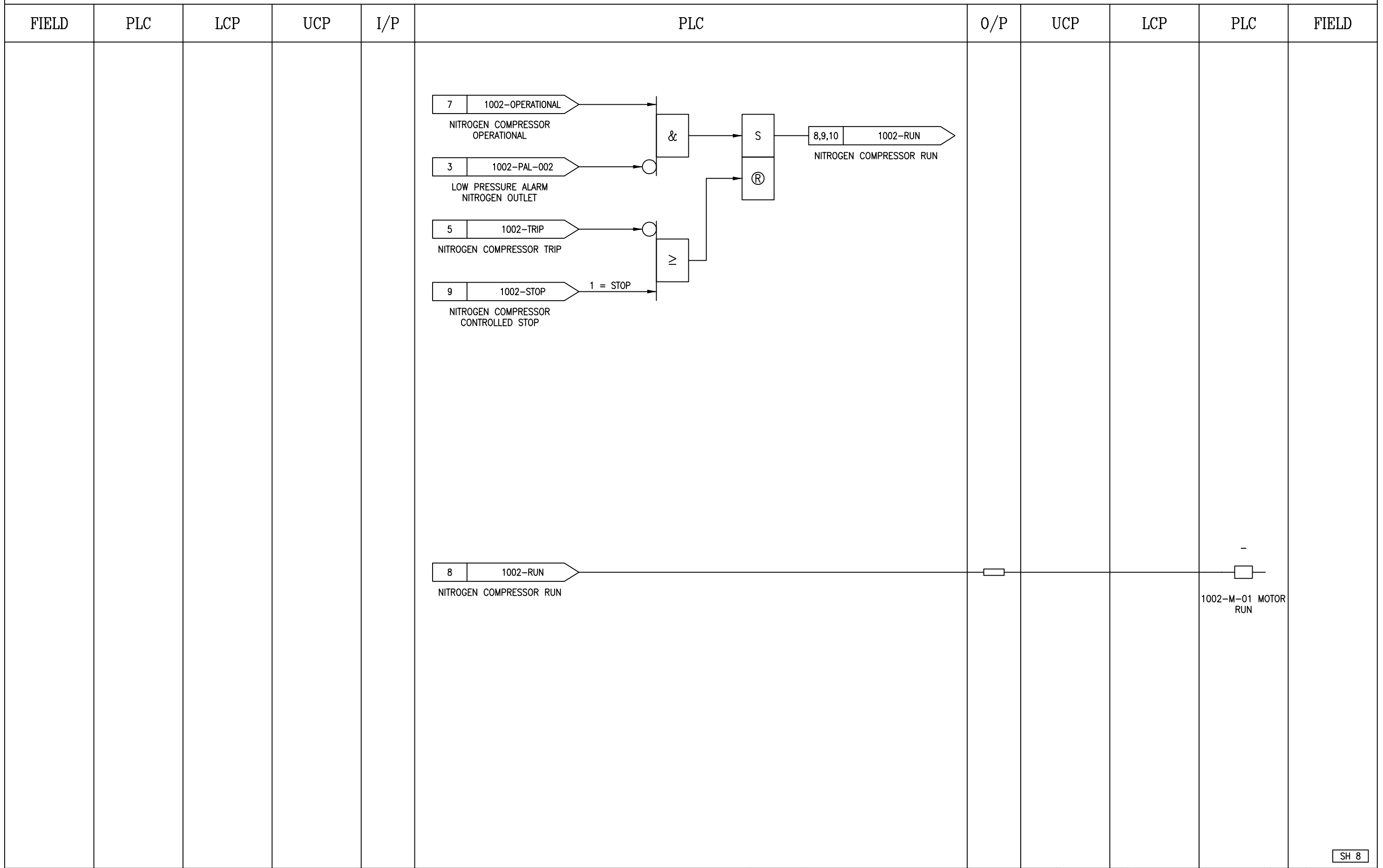

SH 8

NOTES:

	SUBJECT BUSHEHR PETROCHEMICAL COMPANY MEG PLANT NITROGEN COMPRESSOR		DATE 20-11-2020	THIS DRAWING IS OWNED BY AIRPACK AND SHALL NOT BE PRINTED OR COPIED IN ANY OTHER WAY THAN WITH AIRPACKS PERMISSION
	CLIENT BUSHEHR PETROCHEMICAL COMPANY (BUPC)	PLANT LOCATION IRAN	DRAWN BY TJ	
	CLIENT REF 20-C-1002	DRAWING NO. 17811-32	CHECKED BY KP	
	AIRPACK REF 17811	SHEETNO. 08 / 12		
	REV 00	20-11-2020	TJ	

LOGIC DIAGRAM

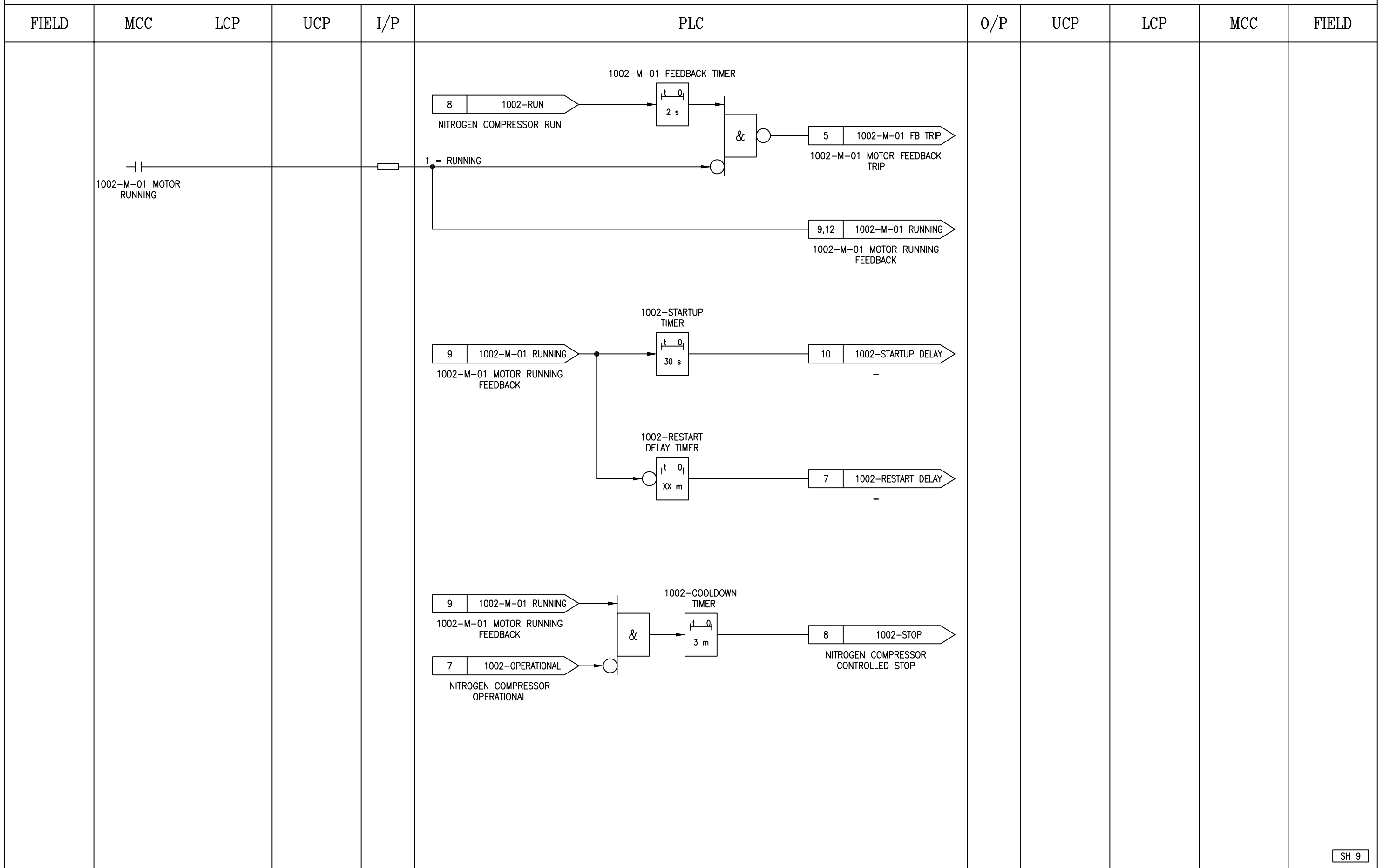

SH 9

NOTES:

	SUBJECT BUSHEHR PETROCHEMICAL COMPANY MEG PLANT NITROGEN COMPRESSOR		DATE 20-11-2020	THIS DRAWING IS OWNED BY AIRPACK AND SHALL NOT BE PRINTED OR COPIED IN ANY OTHER WAY THAN WITH AIRPACKS PERMISSION
			DRAWN BY TJ	
	CLIENT BUSHEHR PETROCHEMICAL COMPANY (BUPC)		CHECKED BY KP	
	CLIENT REF 20-C-1002	PLANT LOCATION IRAN		
AIRPACK REF 17811	DRAWING NO. 17811-32		SHEETNO. 09 / 12	
		REV 00	20-11-2020	TJ

LOGIC DIAGRAM

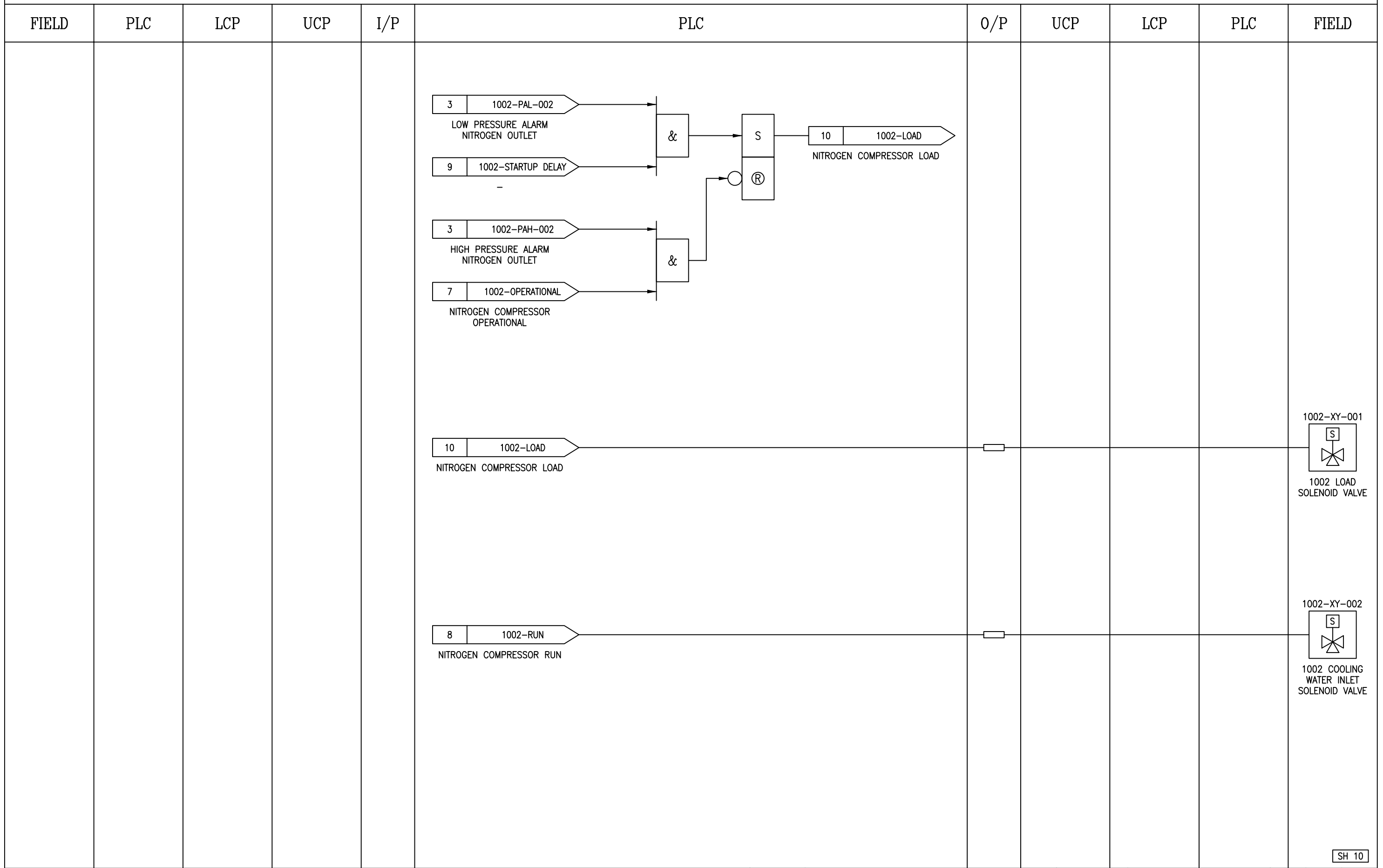

&

S

→

1002-LOAD

NITROGEN COMPRESSOR LOAD

⊙

10

1002-LOAD

→

NITROGEN COMPRESSOR LOAD

8

1002-RUN

→

NITROGEN COMPRESSOR RUN

1002-XY-001

S

⊗

1002 LOAD
SOLENOID VALVE

1002-XY-002

S

⊗

1002 COOLING
WATER INLET
SOLENOID VALVE

NOTES:

	SUBJECT	BUSHEHR PETROCHEMICAL COMPANY MEG PLANT NITROGEN COMPRESSOR	DATE	20-11-2020	THIS DRAWING IS OWNED BY AIRPACK AND SHALL NOT BE PRINTED OR COPIED IN ANY OTHER WAY THAN WITH AIRPACKS PERMISSION
	CLIENT	BUSHEHR PETROCHEMICAL COMPANY (BUPC)	DRAWN BY	TJ	
	CLIENT REF	20-C-1002	CHECKED BY	KP	
	AIRPACK REF	17811	PLANT LOCATION	IRAN	
			DRAWING NO.	17811-32	
		SHEETNO.	10 / 12		

SH 10

LOGIC DIAGRAM

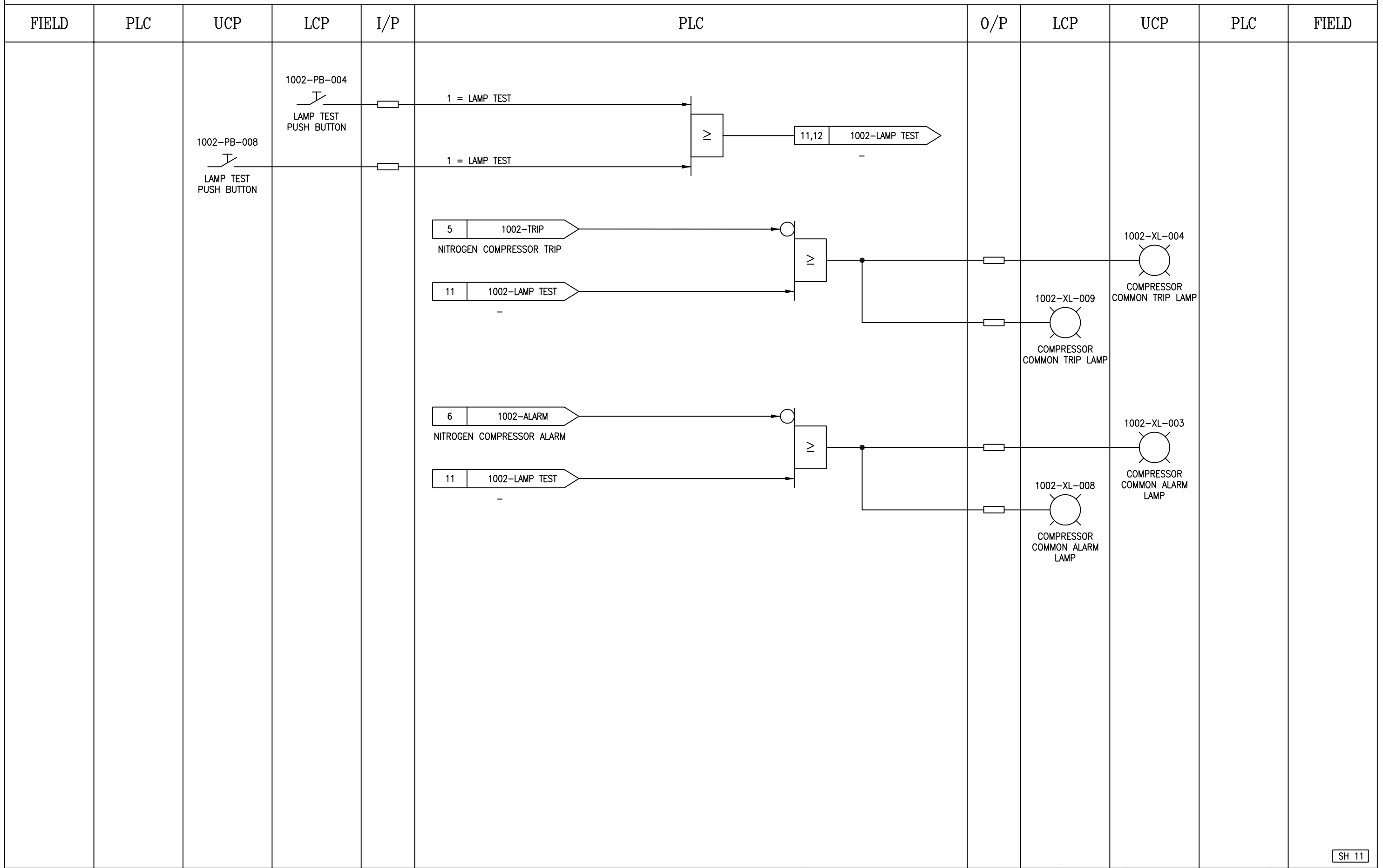

SH 11

NOTES:

	SUBJECT	BUSHEHR PETROCHEMICAL COMPANY MEG PLANT NITROGEN COMPRESSOR	DATE	20-11-2020	THIS DRAWING IS OWNED BY AIRPACK AND SHALL NOT BE PRINTED OR COPIED IN ANY OTHER WAY THAN WITH AIRPACKS PERMISSION
	CLIENT	BUSHEHR PETROCHEMICAL COMPANY (BUPC)	DRAWN BY	TJ	
	CLIENT REF	20-C-1002	CHECKED BY	KP	
	AIRPACK REF	17811	PLANT LOCATION	IRAN	
			DRAWING NO.	17811-32	
			SHEETNO.	11 / 12	

LOGIC DIAGRAM

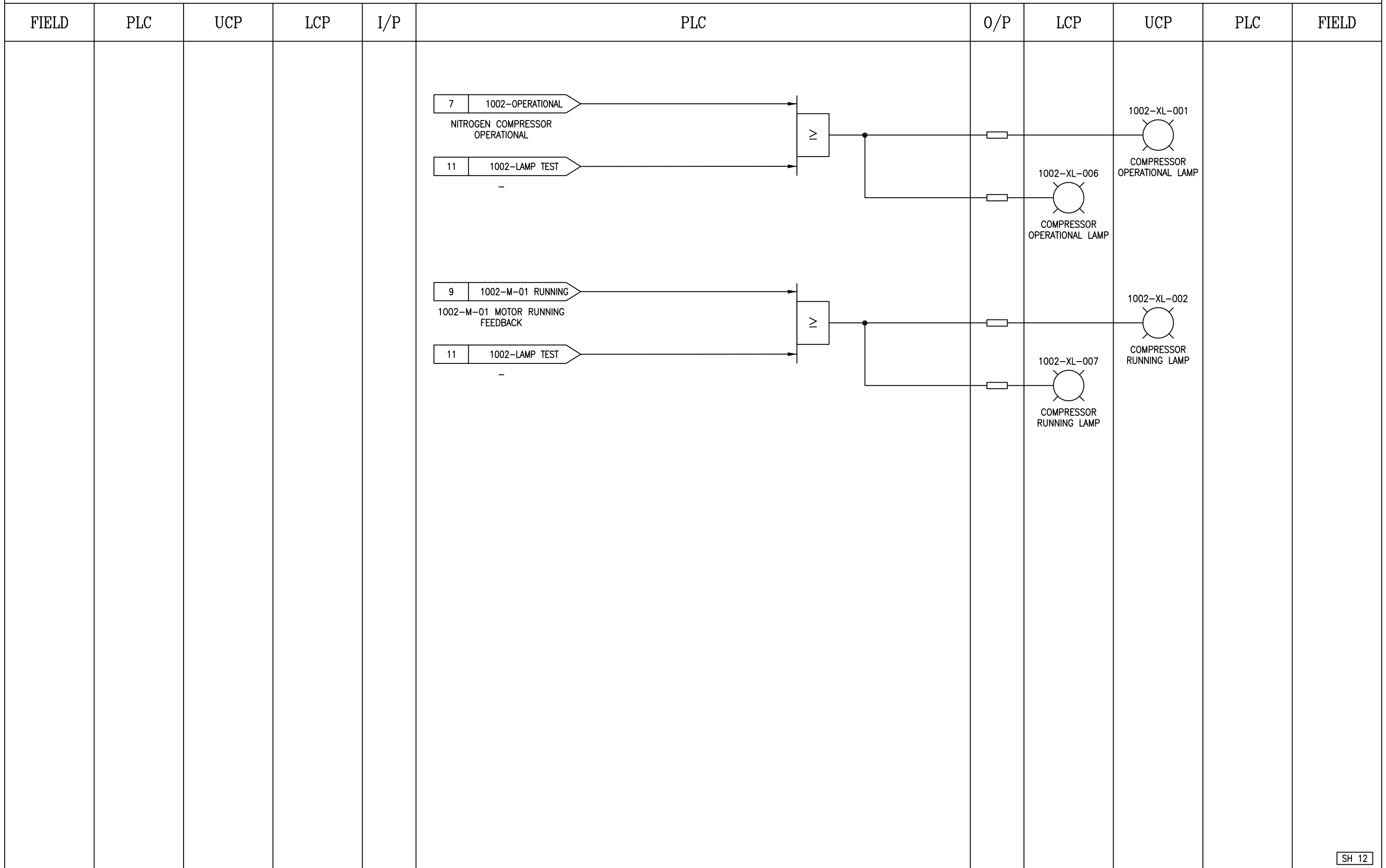

SH 12

NOTES:

	SUBJECT	BUSHEHR PETROCHEMICAL COMPANY MEG PLANT NITROGEN COMPRESSOR	DATE	20-11-2020	THIS DRAWING IS OWNED BY AIRPACK AND SHALL NOT BE PRINTED OR COPIED IN ANY OTHER WAY THAN WITH AIRPACKS PERMISSION
	CLIENT	BUSHEHR PETROCHEMICAL COMPANY (BUPC)	CHECKED BY	KP	
	CLIENT REF	20-C-1002	PLANT LOCATION	IRAN	
	AIRPACK REF	17811	DRAWING NO.	17811-32	
			SHEETNO.	12 / 12	REV 00 20-11-2020 TJ